



UNIQUE
BY SWISS DESIGN

#rondamovement

 **RONDA**

RONDA startech 3500

Chronographs,
eye positions 6-9-12 and 6-12

Caliber 3540.D – 10½ x 11½'''

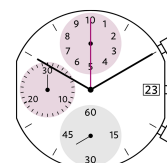
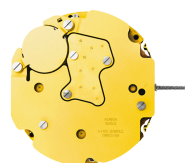

Product Specifications

Analog quartz movement

Line startech

Caliber 3540.D

Size 10½ x 11½'''

Version Swiss Made 5 Jewels / gold plated
Swiss Parts 5 Jewels / nickel plated

Standard battery life 54 months

Hand fitting height 1

Features

- Very long battery life
- Repairable metal watch movement
- Power saving mechanism with pulled out stem: Reduction of consumption approximately 70%
- Very easy handling by two pushers

Functions

- Chronograph
- Center stop second (1/1 sec)
- 1/10 seconds up to 30 minutes
- 30 minute counter
- 10 hour counter
- ADD and SPLIT functions
- 3 eyes
- Small second
- Date

Technical Specifications

Diameter Total	26.20 mm
Case fitting	23.90 mm
Movement height	4.90 mm
Height over standard battery	4.90 mm
Movement rest	0.80 mm
Height over stem	1.70 mm
Length of stem travel	1.00 mm
Stem thread	0.90 mm
Standard battery	384
Standard battery life	54 months
Battery voltage	1.5 V
Current consumption – typical	1.14 µA (Date Mechanism not in Gear)
Current consumption – maximum	1.65 µA (Date Mechanism not in Gear)
Useful torque second – typical	6 µNm
Useful torque minute – typical	300 µNm
Useful torque center stop second – typical	6 µNm
Operating temperature	0 - 50 °C
Instantaneous rate	-10/+20 sec/month
Resistance to magnetic fields	18.8 Oe
Resistance against shock	NIHS 91-10



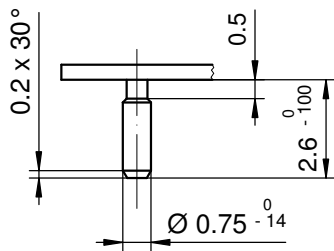
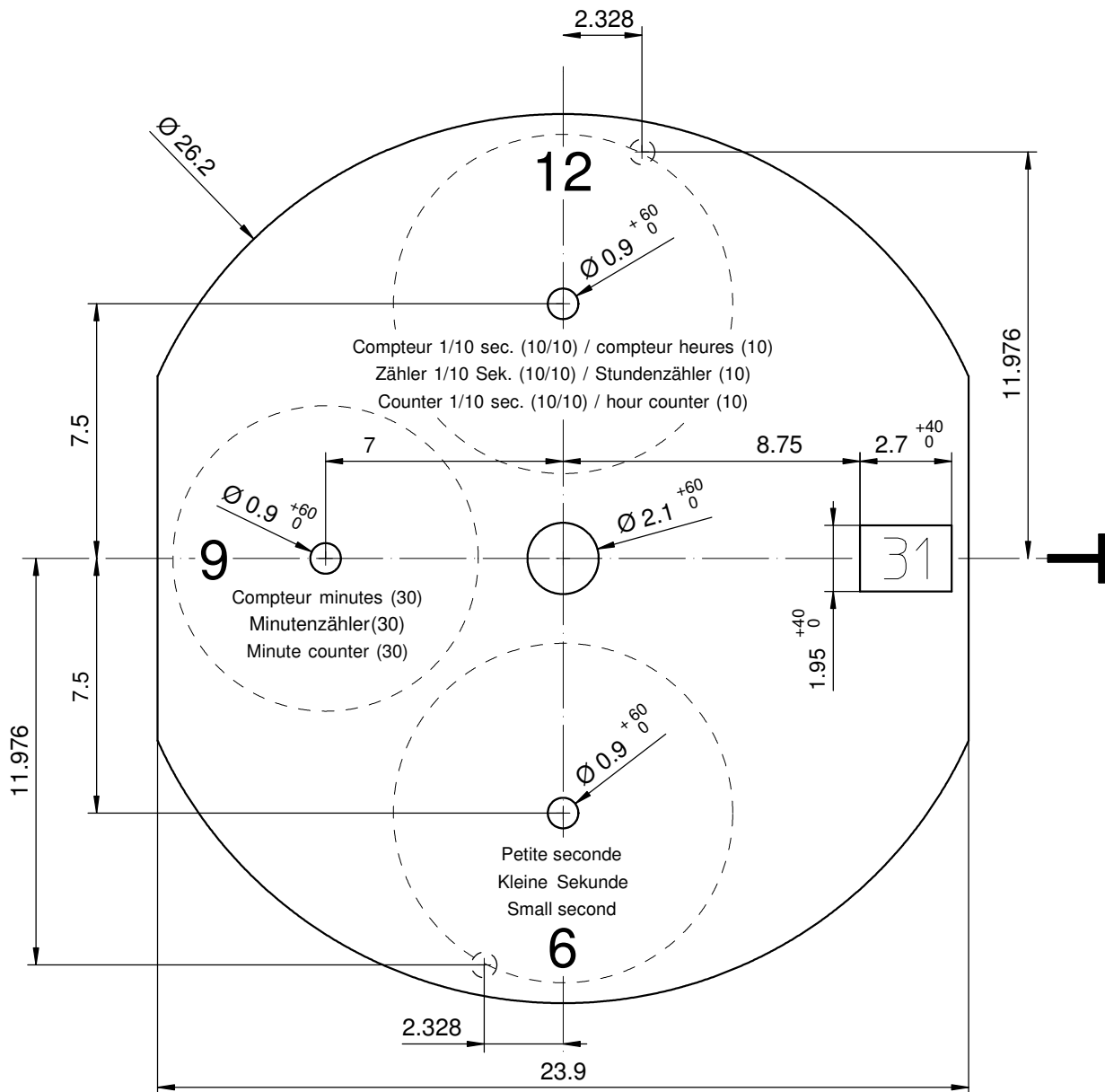

Tige	Date
Stellw.	Datum
Stem	Date
3H	3H

Epaisseur du cadran selon hauteur de l'aiguillage
Zifferblattdicke gemäss Zeigerwerkhöhen
Dial thickness according to hand fitting heights

Cadran Zifferblatt Dial	11½ x 10½"	Issued	05 Mai 2009	mg
		Modified	03 Feb 2011 ÄA 6970	mK
		Released	YES	
		Tolerance	+/- 20 µm	
		Scale	5 : 1 (A4V)	
RONDA	3540.D	Sous réserve de modifications Aenderungenvorbehalten Modifications reserved		
		No.	5010.670	00

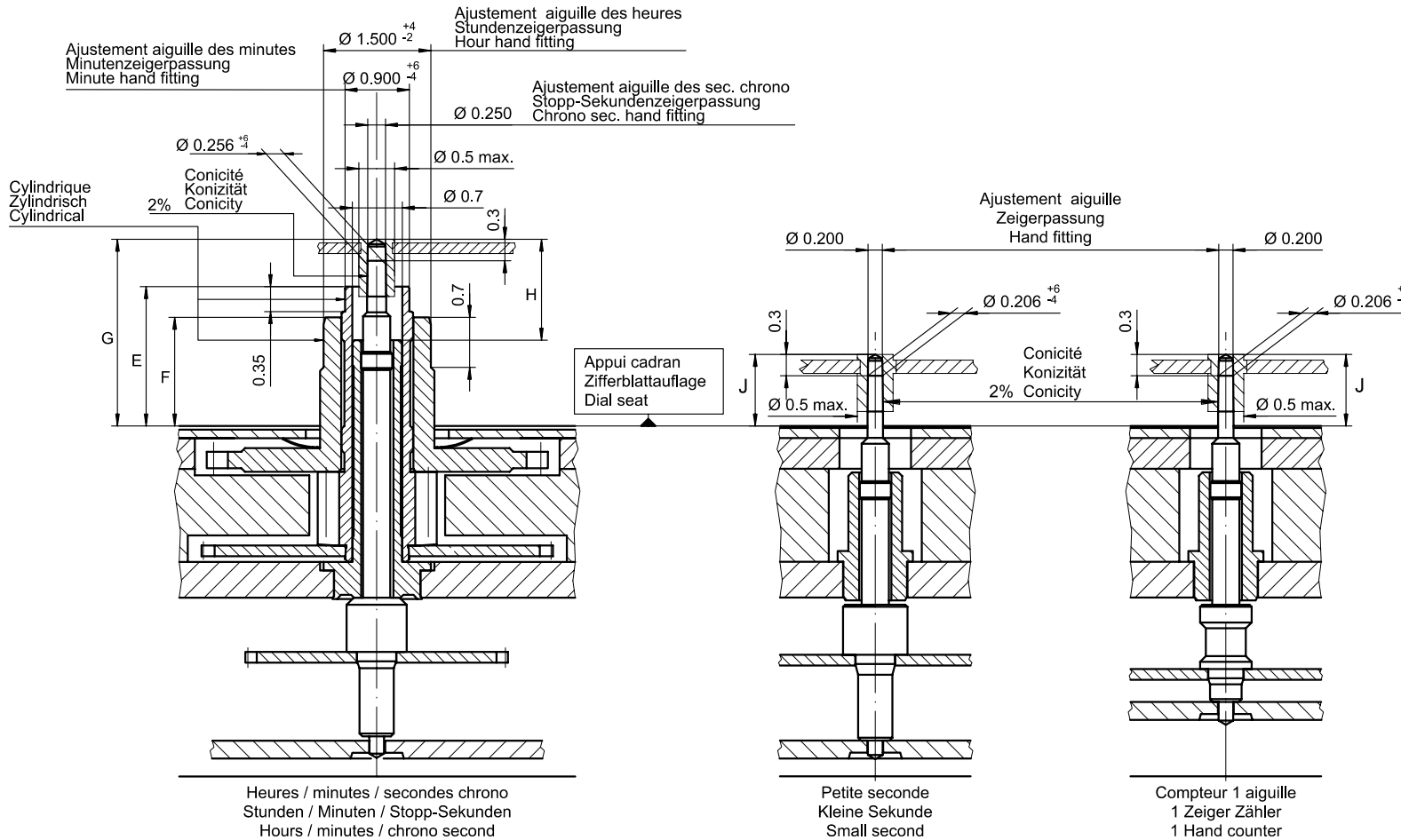

Aiguillages Zeigerwerkhöhe Hand fitting height						
Dépassement Höhe über Zifferblattauflage Height over dial seat						
No	Pignon des secondes chrono Stopp-Sekundentrieb Chrono second pinion	Chaussée Minutenrohr Cannon-pinion	Roue des heures Stundenrad Hour wheel	Petite seconde Kleine Sekunde Small second	Pignon compteur Zählertrieb Counter pinion	1 aig. 1 Zeiger 1 Hand
No	G	E	F	H	J	J
1	2.61	1.95	1.52	1.41	1.00	1.00
-						

Aiguillages Zeigerwerkhöhe Hand fitting height						
Peinture comprise / inkl. Farbe / Paint included						
Epaisseur maximum du cadran Maximale Zifferblattstärke Maximum dial thickness						
No	Sous l'aiguille des secondes chrono Unter Stopp-Sekundenzeiger Under chrono second hand	Sous l'aiguille des minutes Unter Minutenzeiger Under minute hand	Sous l'aiguille des heures Unter Stundenzeiger Under hour hand	Sous l'aiguille de petite seconde Unter kleine Sekundenzeiger Under small second hand	Sous l'aiguille compteur 1 aiguille Unter Zeiger 1 Zeiger Zähler Under hand 1 hand counter	Epaisseur des aiguilles Zeigerdicke Hands thickness
No	1	2.00	1.45	1.00	0.60	0.60
-						

	Aig. des sec. chrono Stopp-Sekundenzeiger Chrono second hand	Aig. des minutes Minutenzeiger Minute hand	Aig. des heures Stundenzeiger Hour hand	Aig. petite secondes Kleine Sekundenzeiger Small second hand	Aiguille compteur (1 aig.) Zähler Zeiger (1 Zeiger) Counter hand (1 hand)	Lors de la pose d'aiguilles, le mouvement doit être soutenu. Beim Zeigersetzen muss das Werk abgestützt werden. The movement needs to be supported for hand setting.
mg max.	10	30	30	10	10	Masse / Masse / Weight *
µNm max.	0.06	0.8	0.8	0.07	0.03	Balourd / Unwucht / Unbalance *
gmm ² max.	1.0	-	-	0.4	1.0	Inertie / Massenträgheit / Inertia *
N max.	30	40	40	30	30	Force de chassage / Aufpresskraft / Force

Sous réserve de toutes modifications

Änderungen vorbehalten

All modifications reserved

Aiguillages Zeigerwerkhöhen Hand fitting heights		11½"	
		RONDA 3540.D	
Issued		30 Apr 2009	mg
Modified		03 Feb 2011 ÄA 6970	mK
Released		YES	
Tolerance		µm	
Scale		15 : 1 (A3H)	
Sous réserve de modifications Änderungen vorbehalten Modifications reserved			
No.	3316.129		00

* En cas de données différentes, veuillez contacter le service après-vente

* Bei abweichenden Werten, bitte technischen Kundendienst anfragen

* In case of different values, please contact the customer service

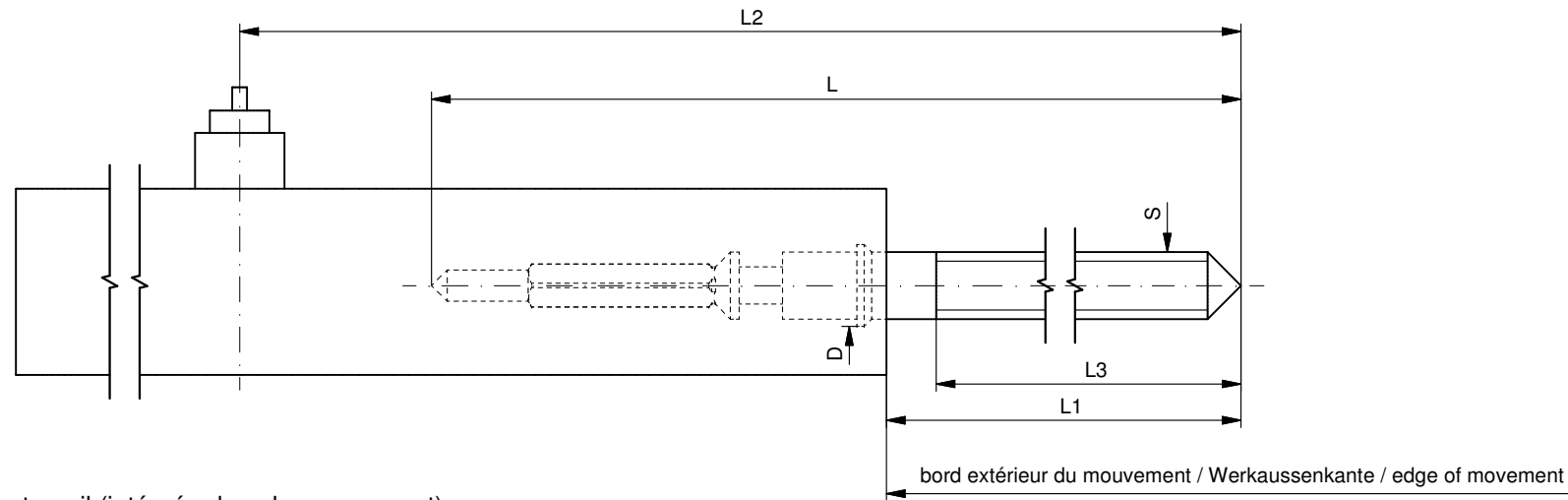

Tige de travail (intégrée dans le mouvement)
 Arbeitstellwelle (im Werk eingebaut)
 Working stem (implemented in the movement)

No. d'article Artikelnummer Part number	L	L1	L2	L3	S	D
3000.205.CO	19.24	10.95	22.90	10.15	0.90	1.10

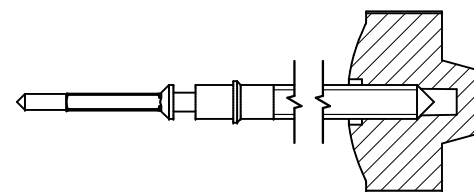

Couleur de la couronne Kronenfarbe Crown color	gris clair hellgrau light grey
Code	UN 7014

Tige (normale) / Stellwelle (normal) / Stem (normal)

No. d'article Artikelnummer Part number	L	L1	L2	L3	S	D
3000.205	19.24	10.95	22.90	10.15	0.90	1.10
3000.210	32.00	23.71	35.66	22.91	0.90	1.10

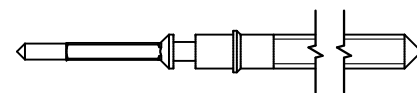

Couronne normale
 Normale Krone
 Normal crown

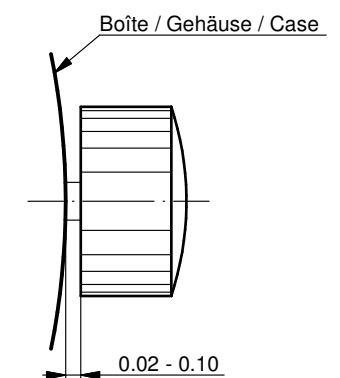

Couronne vissée
 Geschraubte Krone
 Screwed crown

Force ⇐ min. Kraft ⇐ min. Force ⇐ min.	10 N
Force ⇐ max. Kraft ⇐ max. Force ⇐ max.	15 N

Rallonge de tige / Stellwelle Verlängerung / Stem extension

No. d'article Artikelnummer Part number	L4	L5 (min)	L6	S1	S2	D1
3000.040	12.00	1.90	2.60	0.90	0.90	1.35

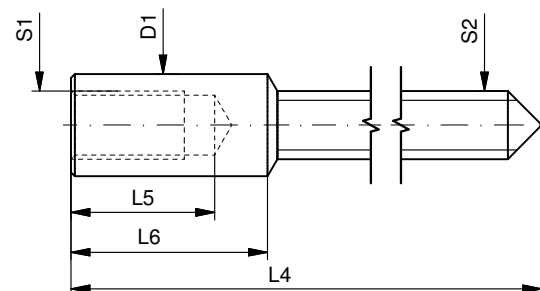

Tige (dimensions / forces)
 Stellwelle (Dimensionen / Kräfte)
 Stem (dimensions / forces)

RONDA 3520.D, 3540.D

Issued	07 Sep 2012	ds5222
Modified	17 Mär 2017 ÄA 34582	mg5224
Released	YES	
Tolerance	---	
Scale	10:1 (A3)	

Sous réserve de modifications
 Änderungen vorbehalten
 Modifications reserved

No.	5030.024	01
-----	----------	----

RONDA startech – Movement cal. 3540.D

User's Manual English

You have decided to buy a watch, which was assembled by a watchmaker using a Ronda movement. Please note that no watches are produced or distributed under the Ronda Brand.

In case of repairs, guarantee claims and questions concerning the functioning of a watch, purchasers and consumers should contact their retailer or the watch manufacturer, for which the relevant information can be found in the sales or guarantee documentation provided with the watch.

Description of the display and control buttons

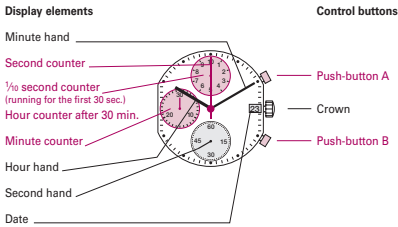

01

Chronograph: Basic function

(Start / Stop / Reset)

Example:

1 **Start:** Press push-button A.

2 **Stop:** to stop the timing, press push-button A once more and read the chronograph counters:
4 min / 38 sek / 1/2 sec

3 **Zero positioning:** Press push-button B. (The chronograph hands will be reset to their zero positions.)

05

Chronograph: Accumulated timing

Example:

1 **Start:** (start timing)

2 **Stop:** (e.g. 15 min 5 sec following 1)

3 **Restart:** (timing is resumed)

4 **Stop:** (e.g. 5 min 12 sec following 3)
= 20 min 17 sec
(The accumulated measured time is shown)

5 **Reset:** The chronograph hands are returned to their zero positions.

Please note:

* Following 4, the accumulation of the timing can be continued by pressing push-button A (Restart / Stop, Restart / Stop, ...).

06

Setting the time

- 1 Pull out the crown to position III (the watch stops).
- 2 Turn the crown until you reach the correct time 8:45.

- 3 Push the crown back into position I.

Please note:

* In order to set the time to the exact second, 1 must be pulled out when the second hand is in position «60». Once the hour and minute hands have been set, 2 must be pushed back into position I at the exact second.

02

Chronograph: Intermediate or interval timing

Example:

1 **Start:** (start timing)

2 **Display interval:** e.g. 20 minutes 17 seconds (timing continues in the background)

3 **Making up the measured time:** (the chronograph hands are quickly advanced to the ongoing measured time.)

4 **Stop:** (Final time is displayed)

5 **Reset:** The chronograph hands are returned to their zero position

Please note:

* Following 4, further intervals or intermediates can be displayed by pressing push-button B (display interval / make up measured time, ...).

07

Setting the date (quick mode)

- 1 Pull out the crown to position II (the watch continues to run).
- 2 Turn the crown anticlockwise until the correct date [1] appears.
- 3 Push the crown back into position I.

Please note:

During the date changing phase between approx. 08.30 PM and 12 PM; the date must be set to the date of the following day.

03

Adjusting the chronograph hands to zero position

Example:

One or several chronograph hands are not in their correct zero positions and have to be adjusted (e.g. following a battery change).

1 Pull out the crown to position III (all chronograph hands are in their correct or incorrect zero position.)

2 Keep push-buttons A and B depressed simultaneously for at least 2 seconds (the second counter hand rotates by 360° → corrective mode is activated.)

08

Setting the date/time

Example:

- Date / time on the watch: [12] / 1:25 AM
- Present date / time: [4] / 8:30 PM

1 Pull out the crown to position II (the watch continues to run).

2 Turn the crown anticlockwise until yesterday's date appears [3].

3* Pull out the crown to position III (the watch stops).

4 Turn the crown until the correct date [4] appears.

5** Continue to turn the crown until the correct time 8:30 PM appears.

6 Push the crown back into position I.

Please note:

* To set your watch to the exact second, please refer to the chapter entitled «setting the time».
** Please observe the AM/PM clock rhythm.

04

Adjusting the second counter hand

Single step: A 1 x short
Continuous: A long

Adjusting the next hand B

Single step: A 1 x short
Continuous: A long

Adjusting the 1/2 second counter hand (position 12h)

Single step: A 1 x short
Continuous: A long

Adjusting the next hand B

Single step: A 1 x short
Continuous: A long

Adjusting the minute counter hand (position 9h)

Single step: A 1 x short
Continuous: A long

Returning the crown to position I

Termination of the chronograph hands adjustment (can be carried out at any time).





Battery type: 384 / SR41SW
Accuracy: +20 / -10 seconds per month

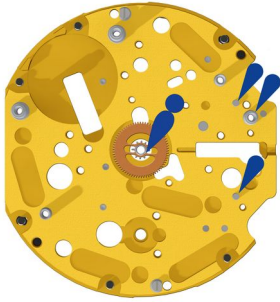

07/2017

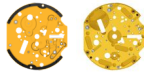



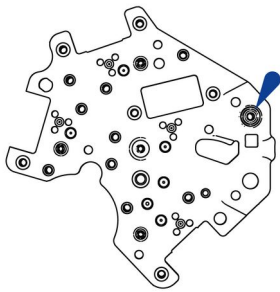



- | | | | |
|---|---|---|------------------------------------|
| 1 |  | 2000.703.G
3305.357.CO | Main plate
Cannon pinion (Aig.) |
| 2 |  | 8200 / J124
1x Jismaa 124
3x Moebius 8200 | Moebius 8200 / Jismaa 124 |

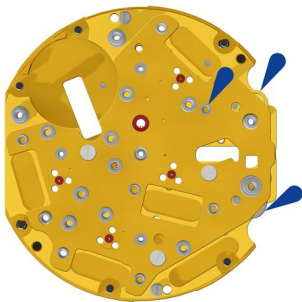





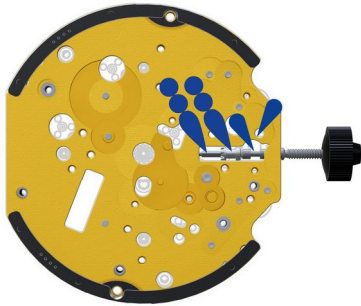

- | | | | |
|---|--|----------|---|
| 4 |  | 3406.030 | Push jumper B
Put the yellow jumper between the two pillars. |
| 5 |  | 3406.038 | Pusher jumper A
Put the grey jumper between the two pillars. |
| 6 |  | 8200 | Moebius 8200
Lubricate the following spare part before assembling. |







- | | | | |
|----|---|-------------|---------------|
| 7 |  | 2030.034.CO | Center bridge |
| 8 |  | 4000.250 | Screw |
| 9 |  | 4000.250 | Screw |
| 10 |  | 4000.250 | Screw |
| 11 |  | 8200 | Moebius 8200 |

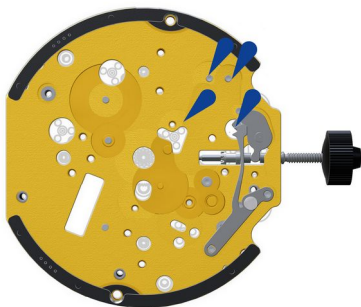



12		3016.030	Stop lever
13		4000.305	Screw
14		3601.140.G	Lateral bridle
15		4000.250	Screw
16		3000.205.CO	Working stem (dual) L19mm
17		3001.066.FI	Sliding pinion
18		8200 / 9020 2x Moebius 9020 2x Moebius 8200	Moebius 8200 / Moebius 9020



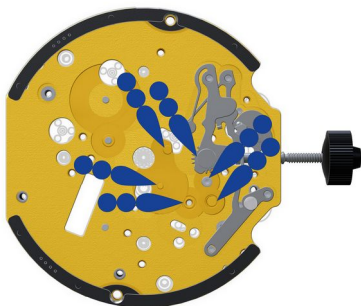



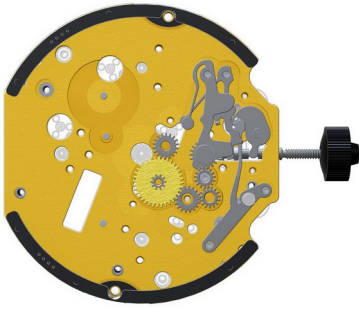

19		3017.061.CO	Setting lever
20		3905.078 Tensioning the spring arm.	Setting lever jumper
21		4000.304	Screw
22		8200	Moebius 8200









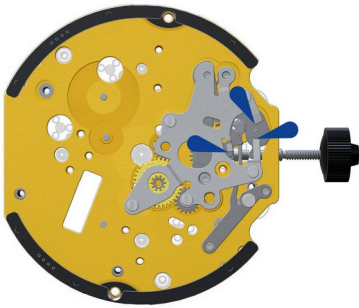





23		3015.092 Tensioning the spring arm.	Yoke
24		3015.093.CO Tensioning the spring arm.	Setting wheel yoke
25		9020	Moebius 9020



26		3004.200	Corrector setting wheel
27		3004.200	Corrector setting wheel
28		3004.234.TA	Date corrector setting wheel
29	 	3007.090.CO	Minute wheel
30		3004.233	Intermediate setting wheel



31		2130.215	Setting mechanism cover
32	 	4000.336	Screw
33	 	4000.336	Screw
34	 	4000.336	Screw
35	 	4000.336	Screw
36	 	4000.336	Screw
37		8200	Moebius 8200

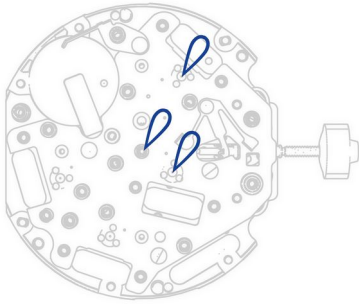

38



9014

Moebius 9014

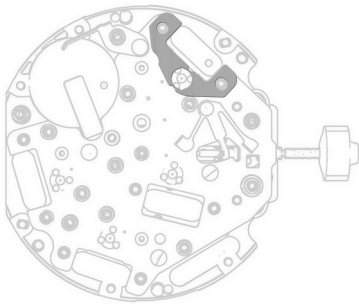

39



3622.057

Stator

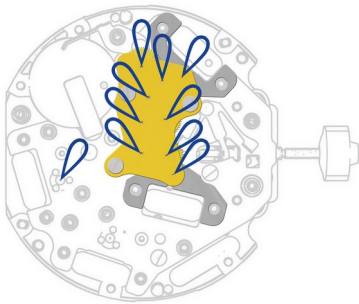

40



3622.057

Stator

41



3715.124.RK

Rotor

42



3715.124.RK

Rotor

43

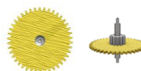

3147.079.CO

Intermediate wheel

44



3136.199.CO

Chronograph wheel (Aig.)

45



3136.198.CO

Second wheel (Aig.)

46



3004.229

Second intermediate wheel

47



3136.197.CO

Small second wheel (Aig.)

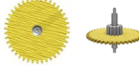
48  3147.079.CO Intermediate wheel

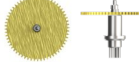
49  3122.069.CO Third wheel

50  2020.199.G Train wheel bridge

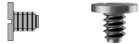
51  4000.282 Screw

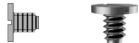
52  4000.282 Screw

53  4000.282 Screw

54  9014 Moebius 9014

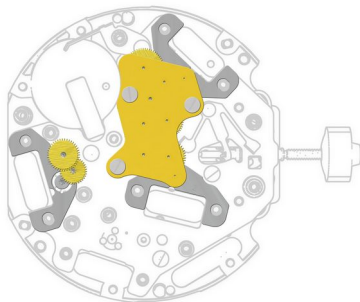

55  3622.059 Stator

56  3715.125.RK Rotor

57  3147.080.CO Intermediate wheel

58  3402.046.CO Minute-counting wheel

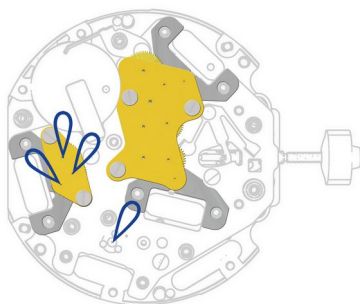

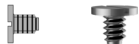

59  2020.203.G Counter train wheel bridge

60  4000.282 Screw



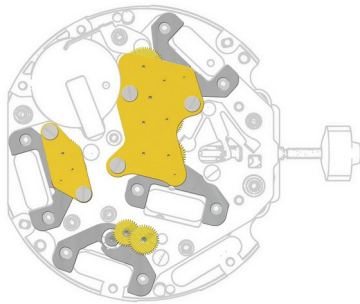

61  4000.282 Screw

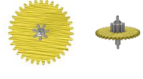
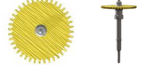
62  9014 Moebius 9014

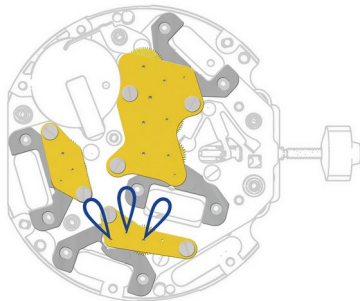





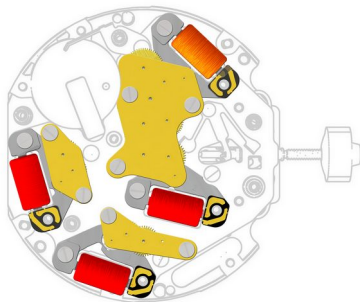

- | | | | |
|----|---|-------------|----------------------------------|
| 63 |  | 3622.058 | Stator |
| 64 |  | 3715.125.RK | Rotor |
| 65 |  | 3147.081.CO | Intermediate wheel |
| 66 |  | 3402.047.CO | Tenth of a second counting wheel |





- | | | | |
|----|---|------------|----------------------------|
| 67 |  | 2020.201.G | Counter train wheel bridge |
| 68 |  | 4000.282 | Screw |
| 69 |  | 4000.282 | Screw |
| 70 |  | 9014 | Moebius 9014 |

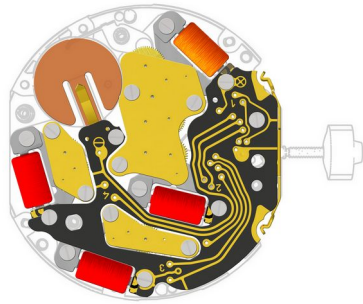

- | | | | |
|----|---|-------------|---|
| 71 |  | 3621.080.RK | Coil
Attention: Please hold the coil only on the grey coil core. |
| 72 |  | 3621.054.RK | Coil
Attention: Please hold the coil only on the grey coil core. |
| 73 |  | 3621.054.RK | Coil
Attention: Please hold the coil only on the grey coil core. |
| 74 |  | 3621.054.RK | Coil
Attention: Please hold the coil only on the grey coil core. |
| 75 |  | 4000.250 | Screw |
| 76 |  | 4000.250 | Screw |
| 77 |  | 4000.250 | Screw |







78   4000.250 Screw



79  3603.092 Battery insulator



80  3601.141.G Contact spring for pusher



81  3612.244.RK.3540 Electronic module



82   4000.248 Screw

83   4000.248 Screw

84   4000.248 Screw



85   4000.248 Screw

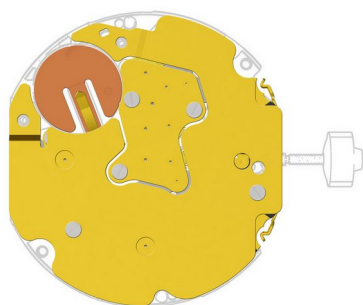

86   4000.248 Screw

87   4000.248 Screw



88  2130.212.G.M01.3540D Electronic modul cover

89   4000.250 Screw

90   4000.250 Screw

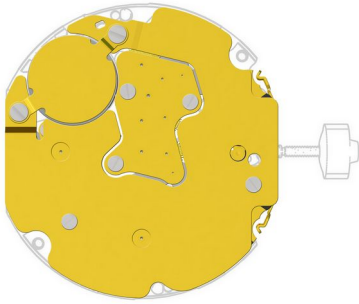



91  3600.011.HGF Battery 384 (Ø 7.90 x 3.60)

92  3601.139.G Bridle +

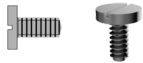
93  4000.335 Screw

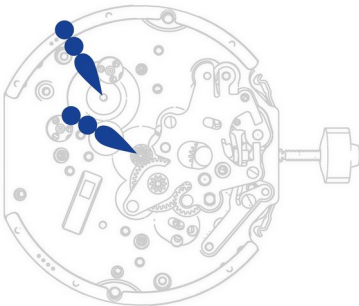
94  4000.335 Screw



95  9020 Moebius 9020

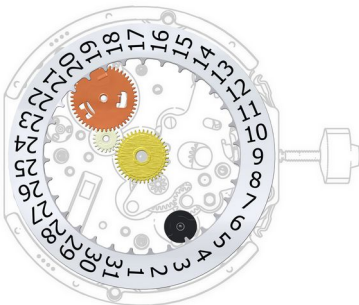

96  3301.317 Hour wheel (Aig.)







97  3507.062 Date corrector

98  3147.082 Intermediate date wheel



99  3004.230.CO Date indicator driving wheel

100  3504.238.AA.1.A Date indicator (T3, G3)



101		2130.213	Date indicator maintaining plate
102		3315.016	Friction spring
103		3905.079	Date corrector spring
104		3500.076	Date jumper
105		3905.077	Date jumper spring
			Lube and insert the spring.
106		8200	Moebius 8200

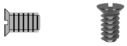
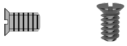
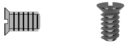

107		2130.214	Date mechanism maintaining plate
108		4000.337	Screw
109		4000.337	Screw
110		4000.337	Screw
111		4000.337	Screw
112		4000.337	Screw

Measurement

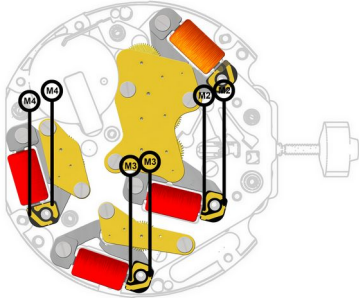

Signal generator (4.9ms, 8Hz)
 < 1.20 V

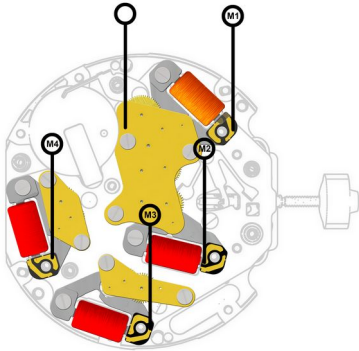

Coil insulation M1 - M4
 infinite

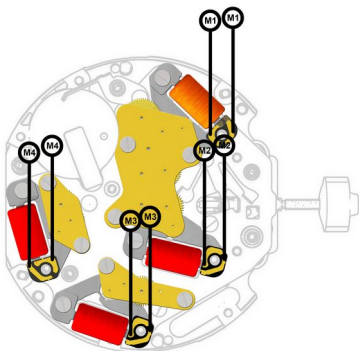

Coil condition movement

Coil condition M2

Coil condition M3

Coil condition M2

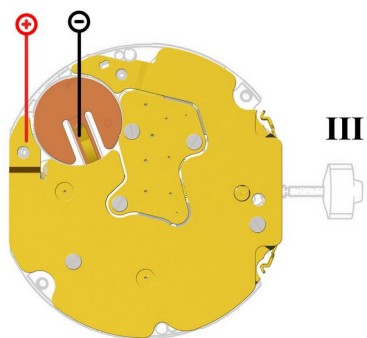

Setting stem in position III, 60 s measuring interval.

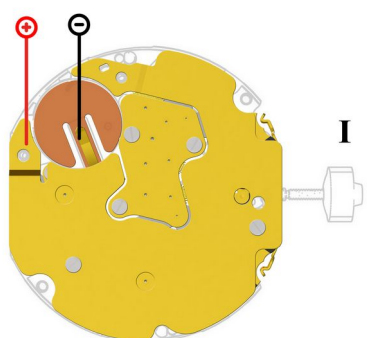

Setting stem in position I, calendar not in gear, 60s measuring interval.

60s measuring interval.

-10 .. +20s/mth

Lower working voltage limit

<1.20 V

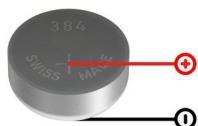

Battery tension