

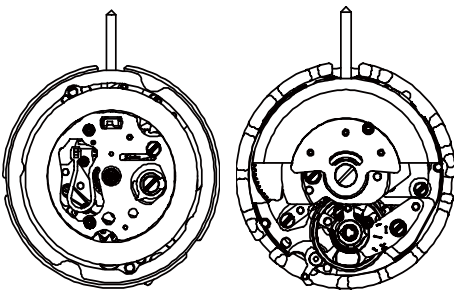

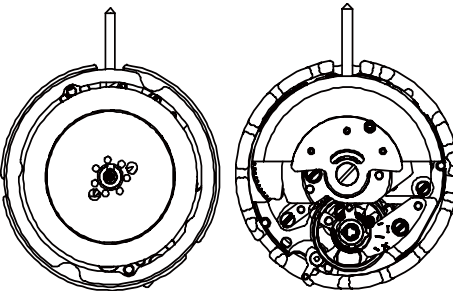

**TECHNICAL GUIDE  
&  
PARTS CATALOGUE**

**Cal.NH0 Series  
(NH05B/06B)**





**AUTOMATIC MECHANICAL**

Cal. No.		NH05B	NH06B
Item			
Movement size	Outside diameter	Φ17.5 mm Φ19.8 mm (with Dial support)	Φ17.5 mm Φ19.8 mm (with Dial support)
	Casing diameter	Φ17.2 mm	Φ17.2 mm
	Total height	5.92 mm (with Dial support)	5.92 mm (with Dial support)
Time indication		3 Hands (Hour , Minute , Second) Date Calendar	3 Hands ( Hour , Minute , Second ) Day & Date Calendar
Basic function		Manual winding Automatic winding with ball bearing Quick date correction	Manual winding Automatic winding with ball bearing Quick day-date correction
Frequency		21,600 vibrations per hour	
Accuracy	Static accuracy	- 35 ~ + 55 seconds per day * Measurement should be done within 10 ~ 60 minutes after fully wound up. * All measurements are made without the calendar in function.	
	Measurement position	Direction of 3 positions. (1) Dial up (2) 9 o'clock up (3) 6 o'clock up	
	Lift angle	52 deg.	
	Measurement time	20 seconds * Equipment to be used : Witschi WATCH EXPERT	
	Posture difference	Difference is under 90 seconds within maximum value and minimum value. * Measurement should be done within 10~60 minutes after fully wound up. * Direction of 4 positions. (1) 12 o'clock up (2) 9 o'clock up (3) 6 o'clock up (4) 3 o'clock up	
Isochronisms (24h-0h)	- 35 ~ +35 seconds per day. * Direction of position. : Dial up * Difference of static accuracy of 24 h and 0 h		
Duration time		More than 40 hours (Mainspring after fully wound up) * Posture to confirmation : Dial up	
Winding the mainspring		<< Movements >> • Fully wound up by turning the crown minimum 55 times. << Complete Watch >> A winding machine is needed to wind up the mainspring. * Full wind up conditions (Reference information) (1) Rotary speed : 30 rpm (2) Operating time: 60 minutes	
Jewels		21 jewels	
Crown position		Counterclockwise	Clockwise
	Normal position	Free	Manual winding
	First click	Date setting	NH05B : Free NH06B : Day setting
	Second click	Time setting	Time setting

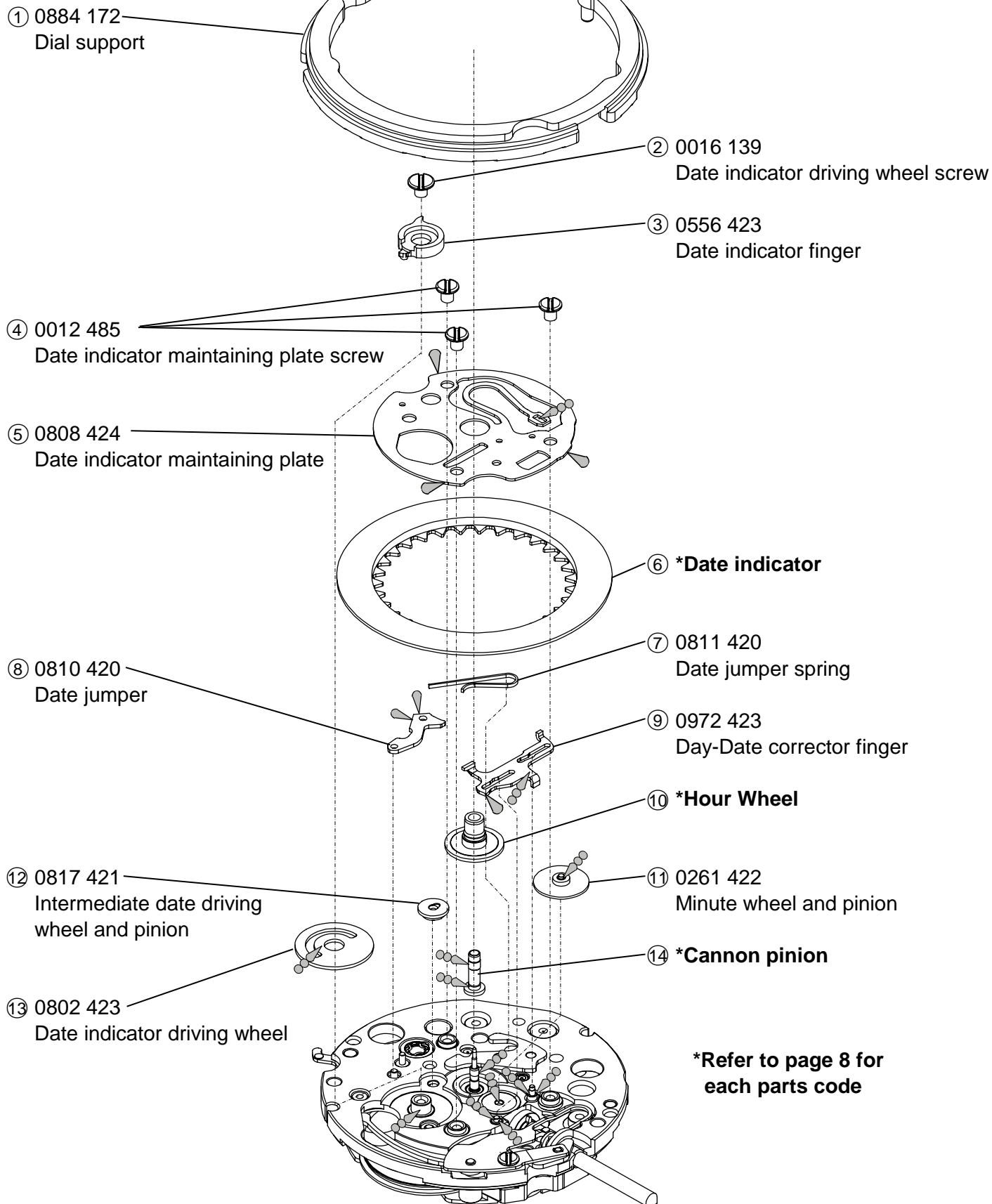
Disassembling procedures Figs. ① → ⑥⑩ Reassembling procedures Figs. ⑥⑩ → ①	<b>Type of oil</b>	<b>Oil quantity mark</b>
	 Moebius 9010  S-6	 NORMAL QUANTITY  SUFFICIENT QUANTITY





## <<NH05B>>

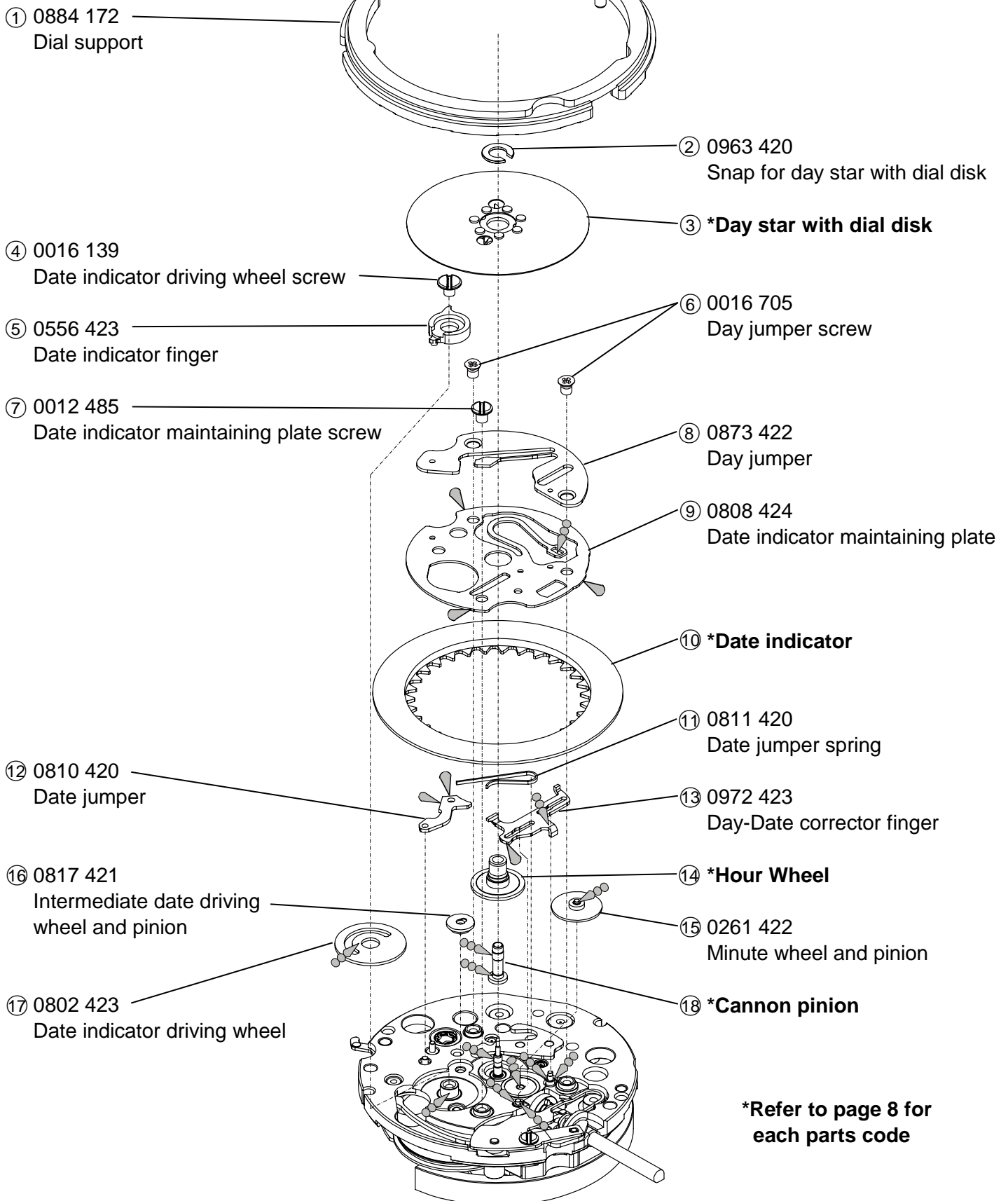

Disassembling procedures Figs. ① → ⑥⑩ Reassembling procedures Figs. ⑥⑩ → ①	<b>Type of oil</b>	<b>Oil quantity mark</b>
	 Moebius 9010  S-6	 NORMAL QUANTITY  SUFFICIENT QUANTITY

## <<NH06B>>



Disassembling procedures Figs. ① → ⑥① Reassembling procedures Figs. ⑥① → ①	<b>Type of oil</b>	<b>Oil quantity mark</b>
	 Moebius 9010  S-6	 NORMAL QUANTITY  SUFFICIENT QUANTITY

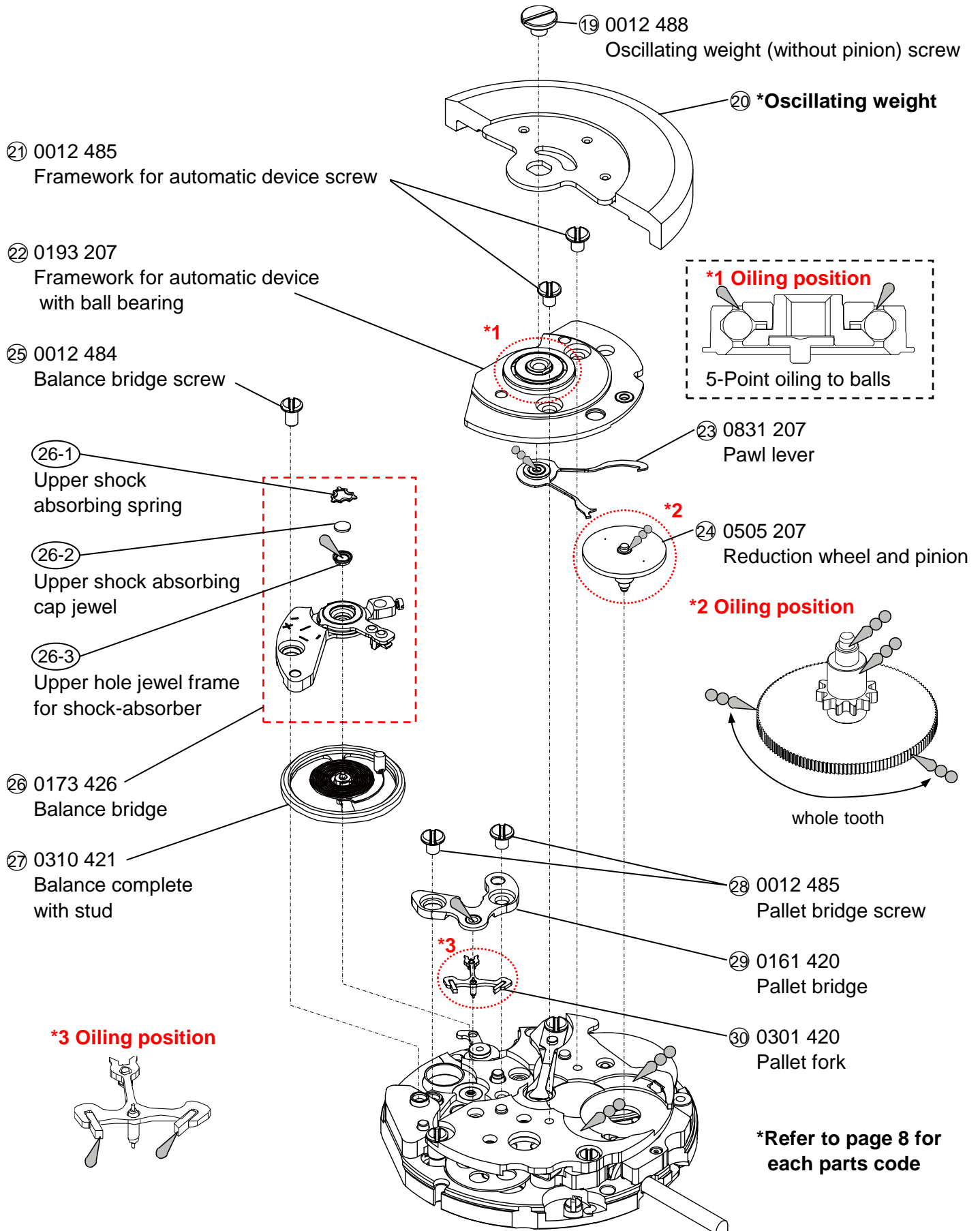

Disassembling procedures Figs. ① → ⑥① Reassembling procedures Figs. ⑥① → ①	<b>Type of oil</b>		<b>Oil quantity mark</b>	
		Moebius 9010		NORMAL QUANTITY
		S-6		SUFFICIENT QUANTITY

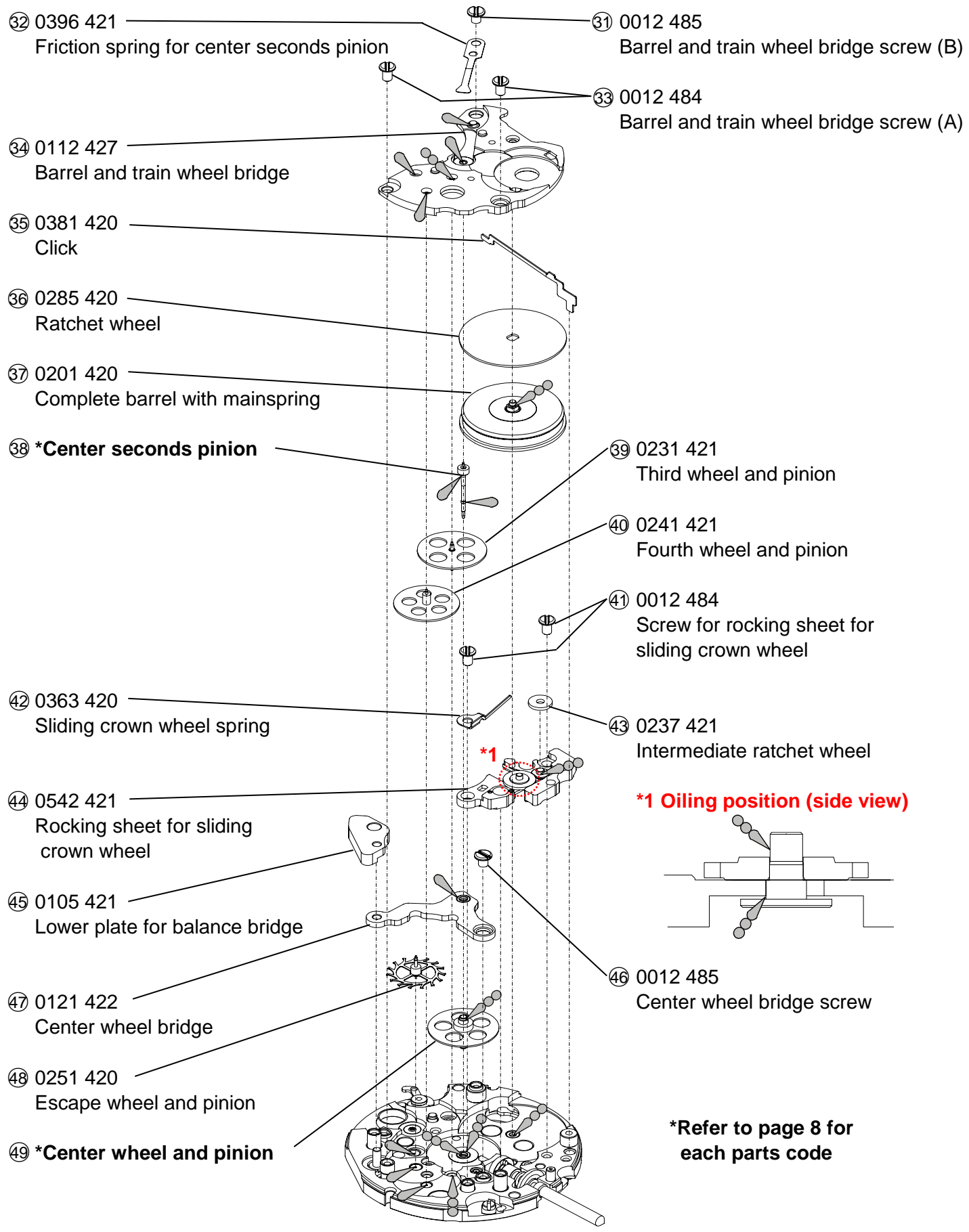

Disassembling procedures Figs. ① → ⑥① Reassembling procedures Figs. ⑥① → ①	<b>Type of oil</b>		<b>Oil quantity mark</b>	
		Moebius 9010		NORMAL QUANTITY
		S-6		SUFFICIENT QUANTITY

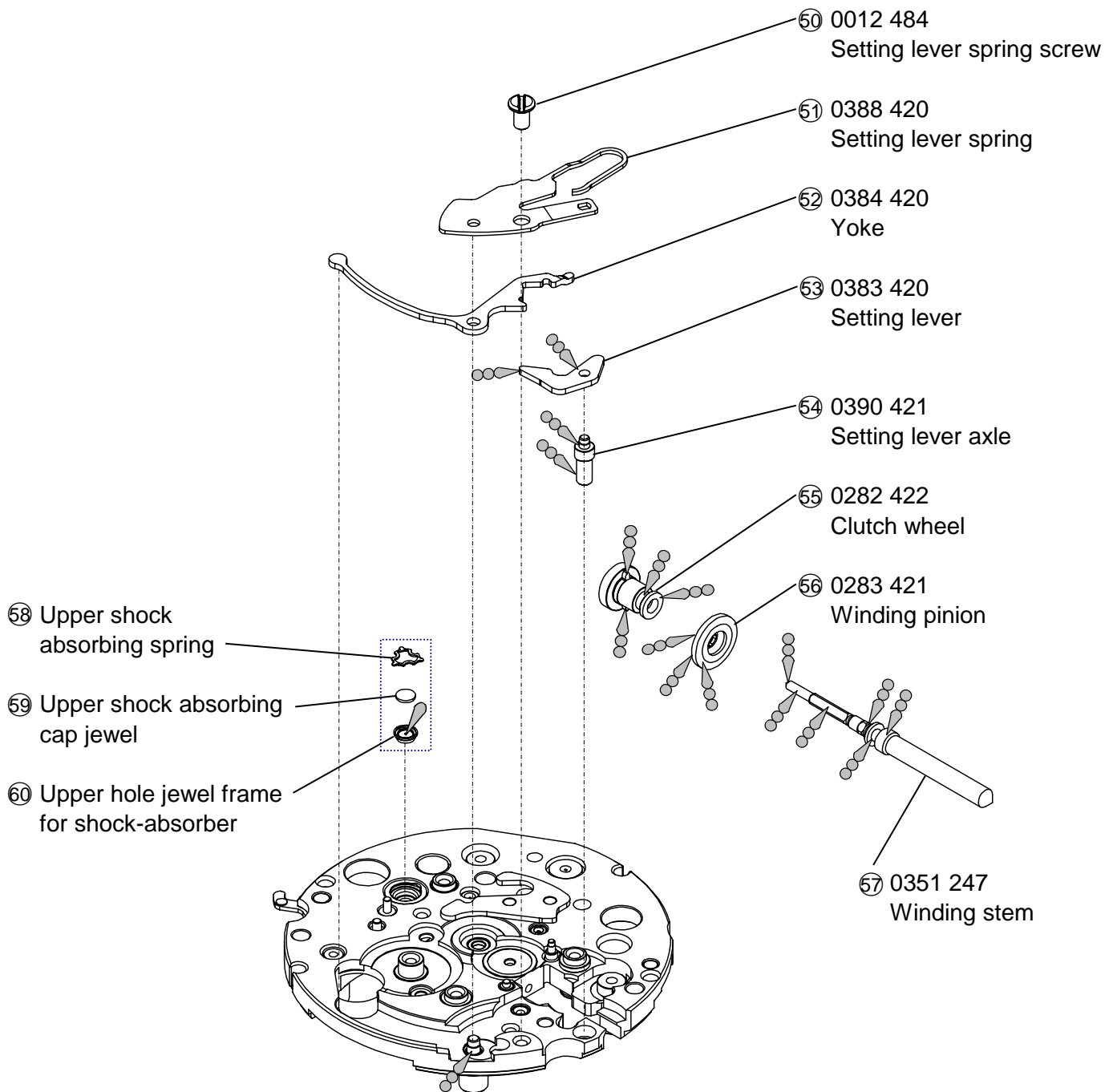

## Remarks

### ● List of screws

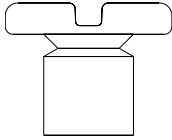
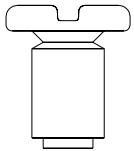
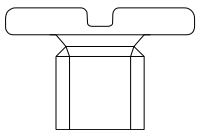
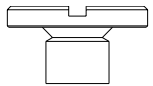
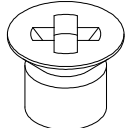
Parts No.	Appearance	Page	Parts Name	Q'ty
0012 485		2	④ Date indicator maintaining plate screw	3
		3	⑦	1
		4	⑳ Framework for automatic device screw	2
		4	㉘ Pallet bridge screw	2
		5	㉛ Barrel and train wheel bridge screw (B)	1
		5	㉞ Center wheel bridge screw	1
0012 484		4	㉝ Balance bridge screw	1
		5	㉜ Barrel and train wheel bridge screw (A)	2
		5	㉟ Screw for rocking sheet for sliding crown wheel	2
		6	㉡ Setting lever spring screw	1
0016 139		2	② Date indicator driving wheel screw	1
		3	⑦	
0012 488		4	⑲ Oscillating weight (without pinion) screw	1
0016 705		3	⑥ Day jumper screw	2

**\*All parts code are subject to change without notice.**



## Remarks

### ③ Day star with dial disk (Page 3)

Cal.	Parts code	Position of crown	Position of day frame	Color of letters	Color of background	Language
NH06B	0160 355	3H	3H	MON ~ FRI : Black SAT : Blue SUN : Red	White	English & Chinese

### ⑥ Date indicator (Page 2)

Cal.	Parts code	Position of crown	Position of date frame	Color of numbers	Color of background
NH05B	0878 425	3H	3H	Black	White

### ⑩ Date indicator (Page 3)

Cal.	Parts code	Position of crown	Position of date frame	Color of numbers	Color of background
NH06B	0148 085	3H	3H	Black	White

### ⑩ Hour Wheel (Page 2)

Cal.	Parts code
NH05B	0271 425

### ⑭ Hour Wheel (Page 3)

Cal.	Parts code
NH06B	0271 425

### ⑭ Cannon pinion (Page 2)

Cal.	Parts code
NH05B	0225 422

### ⑱ Cannon pinion (Page 3)

Cal.	Parts code
NH06B	0225 422

### ⑳ Oscillating weight (Page 4)

Cal.	Parts code	Marking	Cal.	Parts code	Marking
NH05B	1500 436	Japan mark	NH06B	1500 438	Japan mark
	1500 446	Malaysia mark		1500 448	Malaysia mark
	1500 487	China mark		1500 489	China mark

### ⑳ Center second pinion (Page 5)

Cal.	Parts code
NH05B NH06B	0245 425

### ④⑨ Center wheel and pinion (Page 5)

Cal.	Parts code
NH05B NH06B	0224 425

**\*All parts code are subject to change without notice.**

•The following explanation is only for Cal.NH05/06B.

NH05B ⑤ (Page 2) Date indicator maintaining plate

NH06B ⑨ (Page 3)

Day-Date corrector finger is set to the hole of Date indicator maintaining plate.

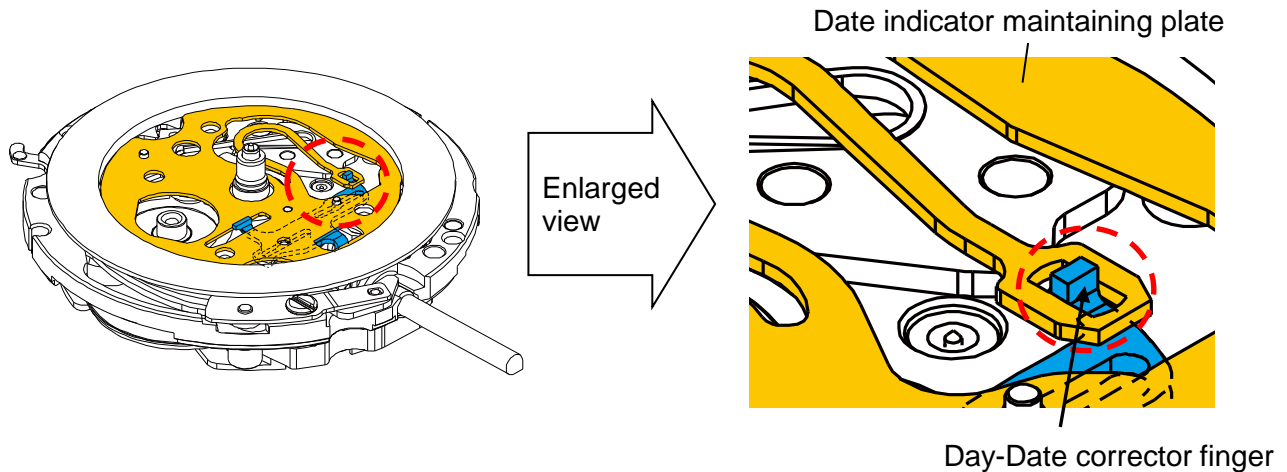

### ⑬ Pawl lever (Page 4)

Pawl lever has to be set to engage with the teeth of Reduction wheel and pinion.

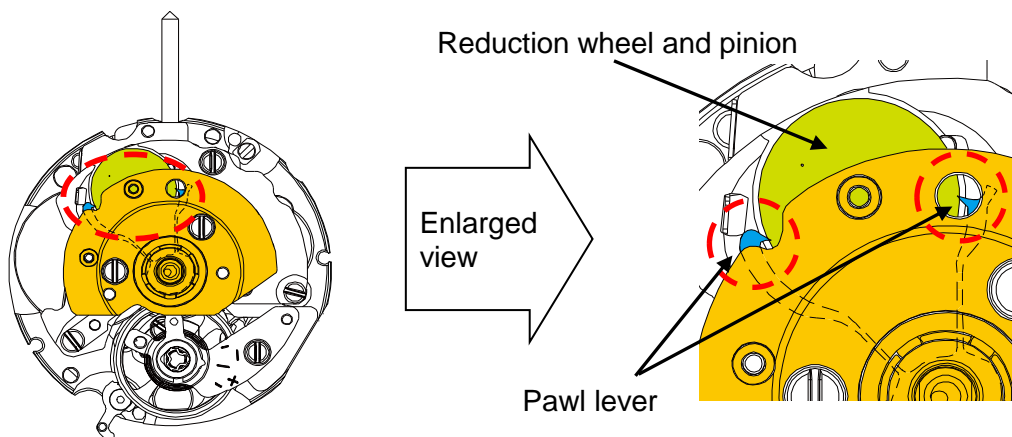

### ⑭ Sliding crown wheel spring (Page 5)

Please set Sliding crown wheel spring to the side of Sliding crown wheel.

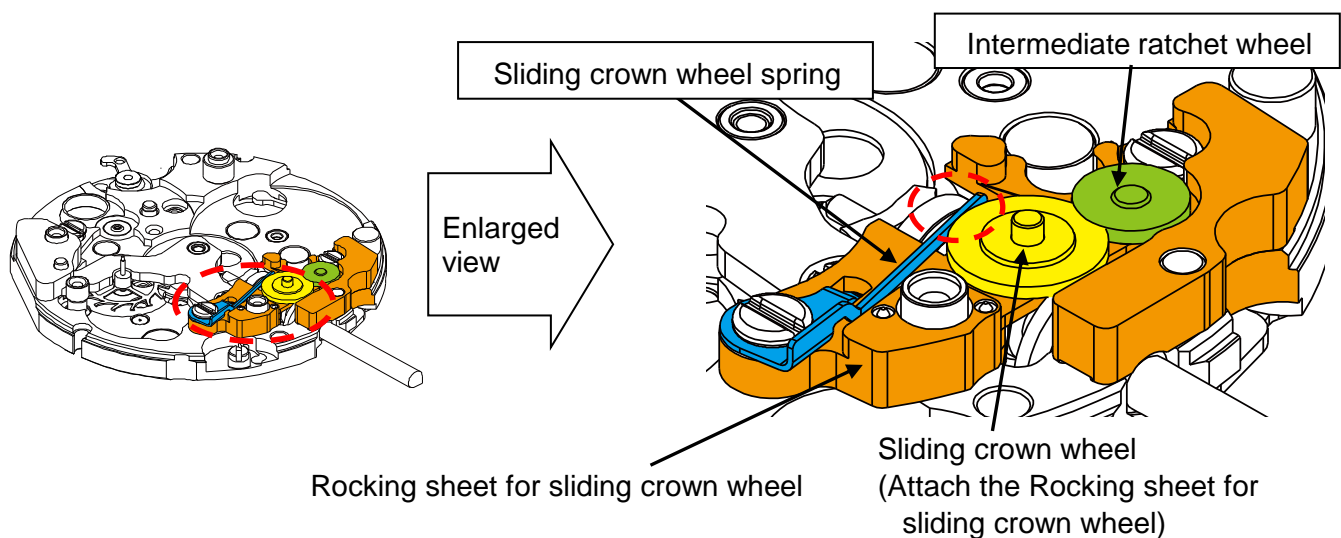

## 1. Setting position

Date jumper spring \*1

Date jumper \*2

Day-Date corrector finger \*3

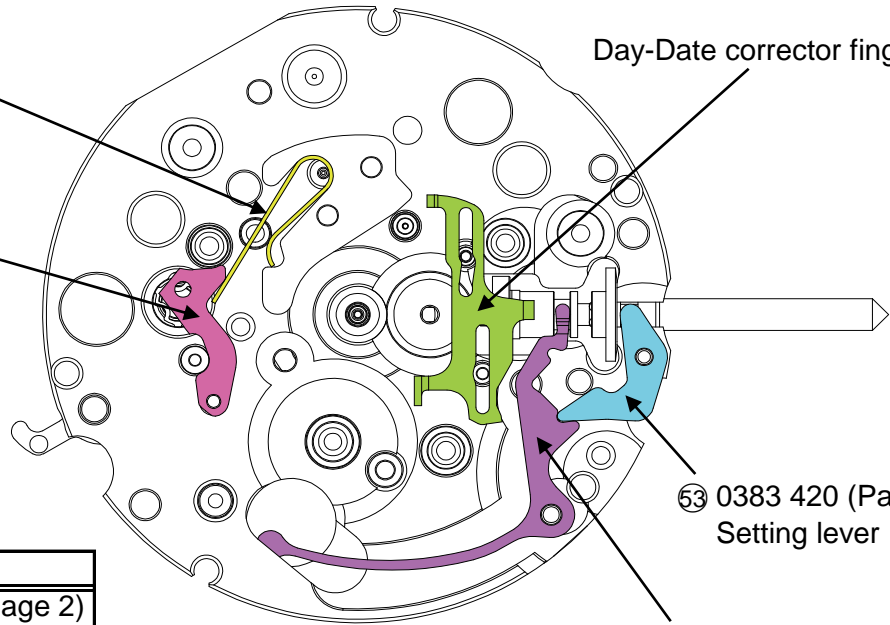

⑤③ 0383 420 (Page 6)  
Setting lever

⑤② 0384 420 (Page 6)  
Yoke

Parts code	Cal.
*1 0811 420	NH05B ⑦ (Page 2) NH06B ⑪ (Page 3)
*2 0810 420	NH05B ⑧ (Page 2) NH06B ⑫ (Page 3)
*3 0972 423	NH05B ⑨ (Page 2) NH06B ⑬ (Page 3)

## 2. Setting position of oscillating weight

• Before assembling oscillating weight.

Please set Oscillating weight according to the straight part of Framework for automatic device.

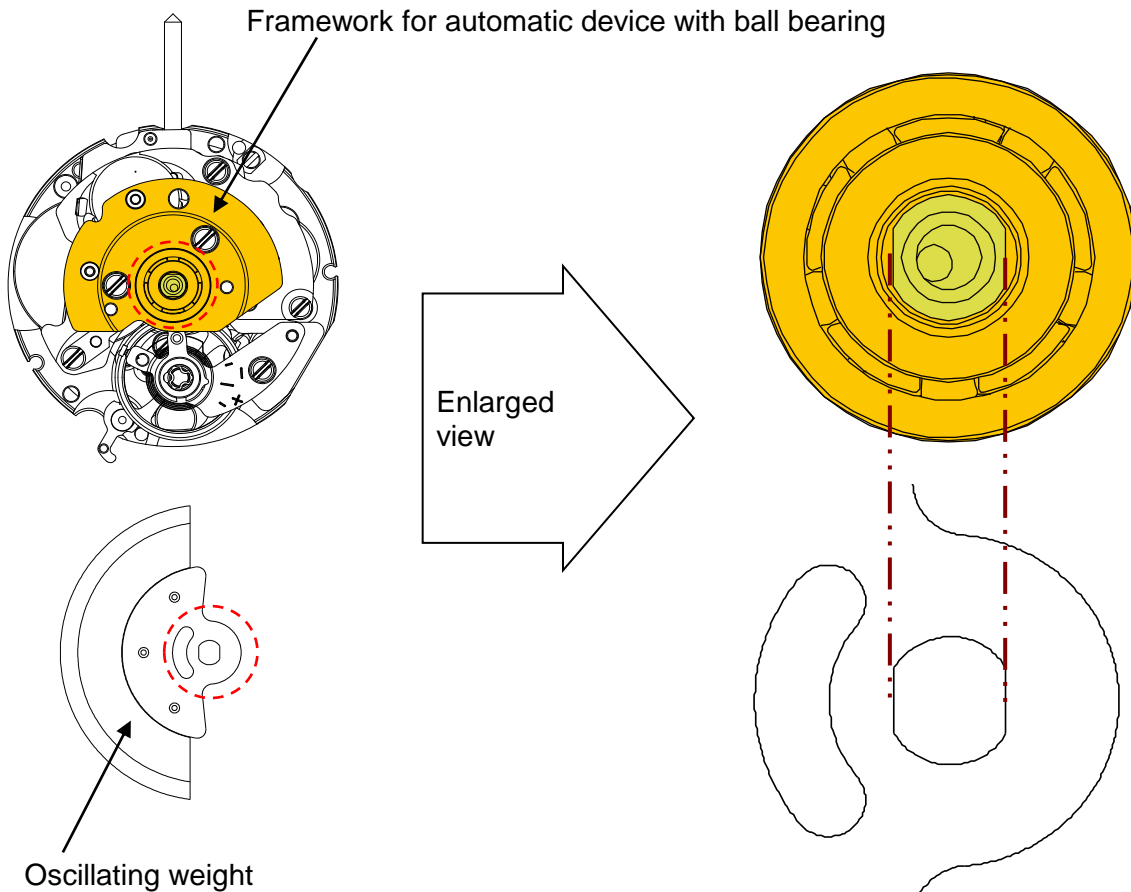

### 3.How to install hands

Place the movement directly on a flat metal plate or something similar to install the hands.  
We recommend the use of movement holder to install hands.  
For hands attachment, please use a special equipment.  
When the movement receives a strong shock, it may be damaged.

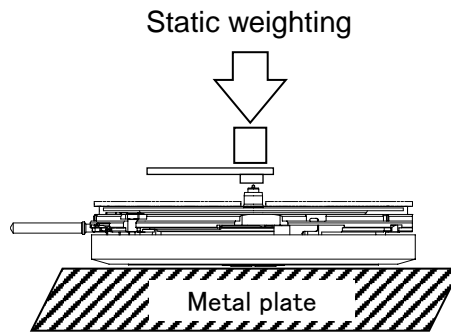

### 4.Accuracy measurement condition

Static Accuracy : - 35 ~ + 55 seconds per day

Measurement Conditions

- 1) Measurement should be done within 10 ~ 60 minutes after fully wound up.
- 2) Lift angle : 52 deg.
- 3) Measurement position : (1) Dial up (2) 9 o'clock up (3) 6 o'clock up
- 4) Minimum measurement Time : 20 seconds
- 5) Stabilizing Time :

Leave the watch for at least 20 seconds to stabilize after you change its measurement position.

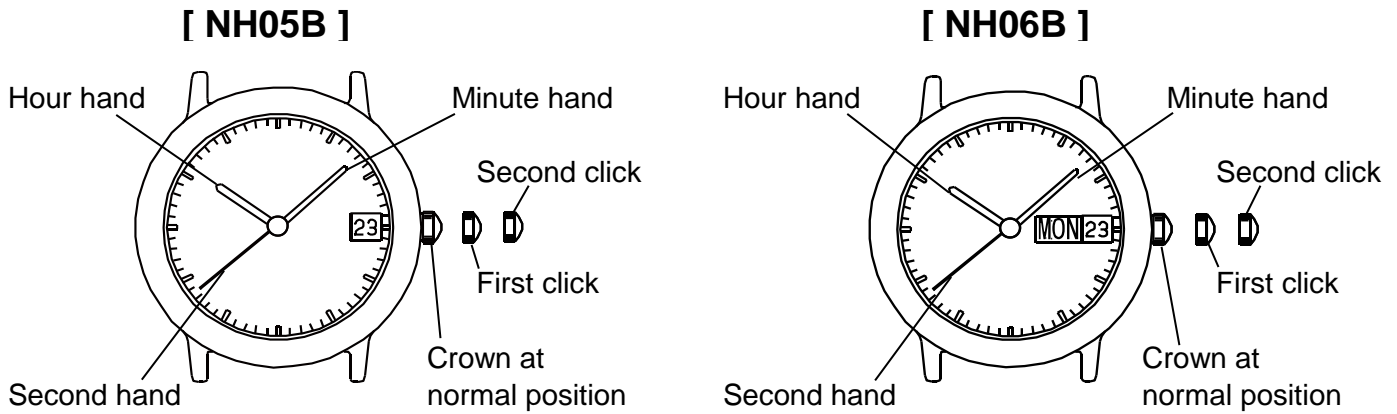

### 1. Time setting

- 1) Pull out the crown to the second click position.
- 2) Turn the crown to set hour and minute hands.  
(Check that AM/PM is set correctly.)
- 3) Push the crown back into the normal position.

### 2. Date setting

- 1) Pull out the crown to the first click position.
- 2) Turn the crown to left for date setting.  
\* Do not set the calendar between 10:00 P.M. and 1:00 A.M.  
If the setting of the calendar is made during this period, the date will not change to the next date.  
Please set the calendar after changing the time other than the above period.
- 3) Turn the crown to right for day setting. (Cal.NH06B only)
- 4) Push the crown back into the normal position.

### 3. To wind up the mainspring

- a) Manual winding (Rotate the crown clockwise at normal position)  
Fully wound up by turning the crown minimum 55 times.
- b) To wind up with winding machine.  
Full wind up conditions (Reference information)
  - Rotary speed : 30 rpm
  - Operating time : 60 minutes