

Watch Movement Specification and Drawing

Basic Mechanical Movement

NH35A

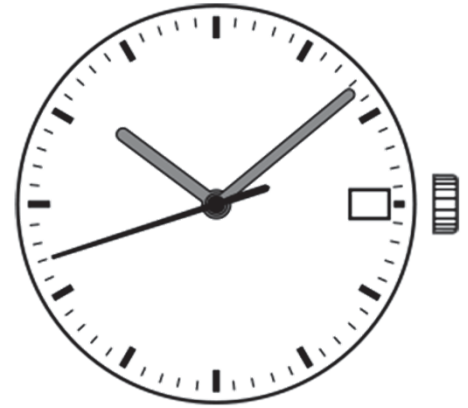

Movement Size: **12'''**

Diameter: **Φ27.40mm** (Φ29.36mm with Dial Holding Spacer)

Height: **5.32mm**

Items	Ver.	Items	Ver.
Specification	1		
Appearance - 1	1		
Appearance - 2	1		
Casing	1		
Hand Fitting	1		
Hand Setting Stem	1		
Dial	1		
Assembly Plan	1		
Hands	1		

CAL.NH35A 12 Ligne Mechanical Movement

Three Hands with Date

1. FUNCTION

- Jewel 24 jewels
- Accuracy -20 ~ +40 seconds / day (23 ± 2 °C)
- Regulation hands unbalance
 - Hour hand : Less than 1.50 μN·m (150 mg·mm)
 - Minute hand : Less than 1.25 μN·m (125 mg·mm)
 - Second hand : Less than 0.60 μN·m (60 mg·mm)

- Additional function
 - Manual winding
 - Automatic winding with ball bearing
 - Both winding with one way clutch
 - Second hand stop mechanism
 - Date display with quick date correction

2. USE AND TEST CONDITION

- Vibration frequency 21,600 vibrations per hour
- Duration time More than 41 hours
- Antimagnetic ≥ 4800 A / m (Direct current magnetic field)
- Test of accuracy 20 seconds (Duration of measurement)
- Casing
 - *1. Screw type case back is required
 - *2. Non-corresponding with Diver's watch

*** All specifications are subject to change without notice.**

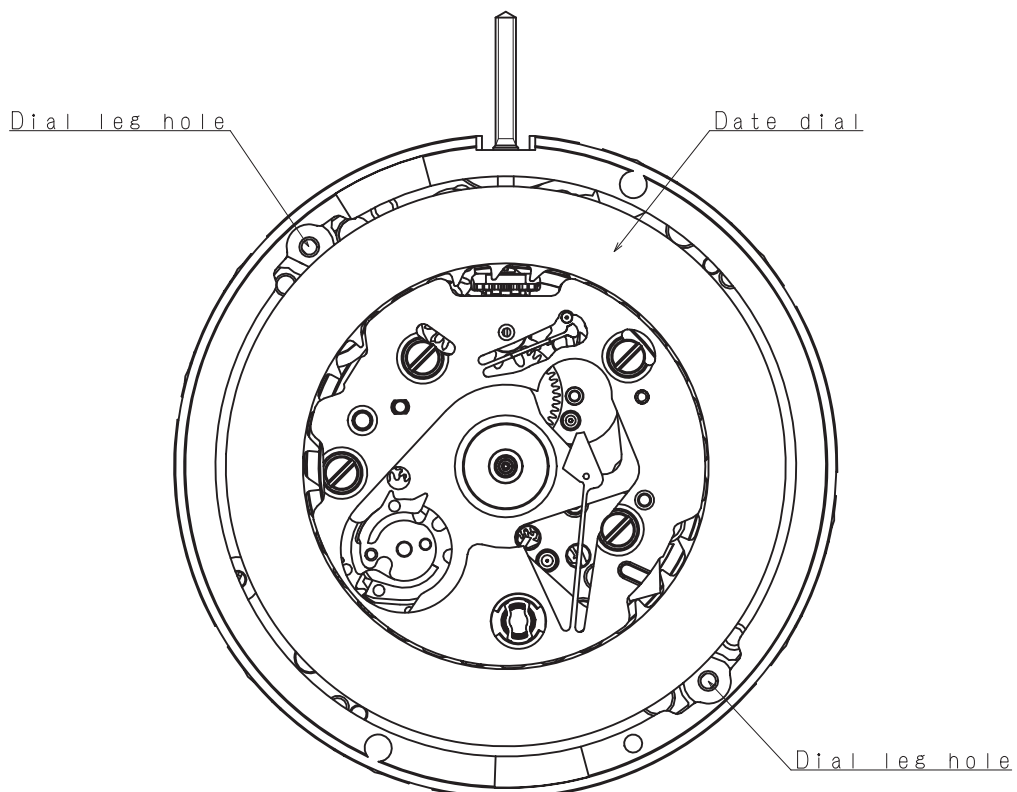
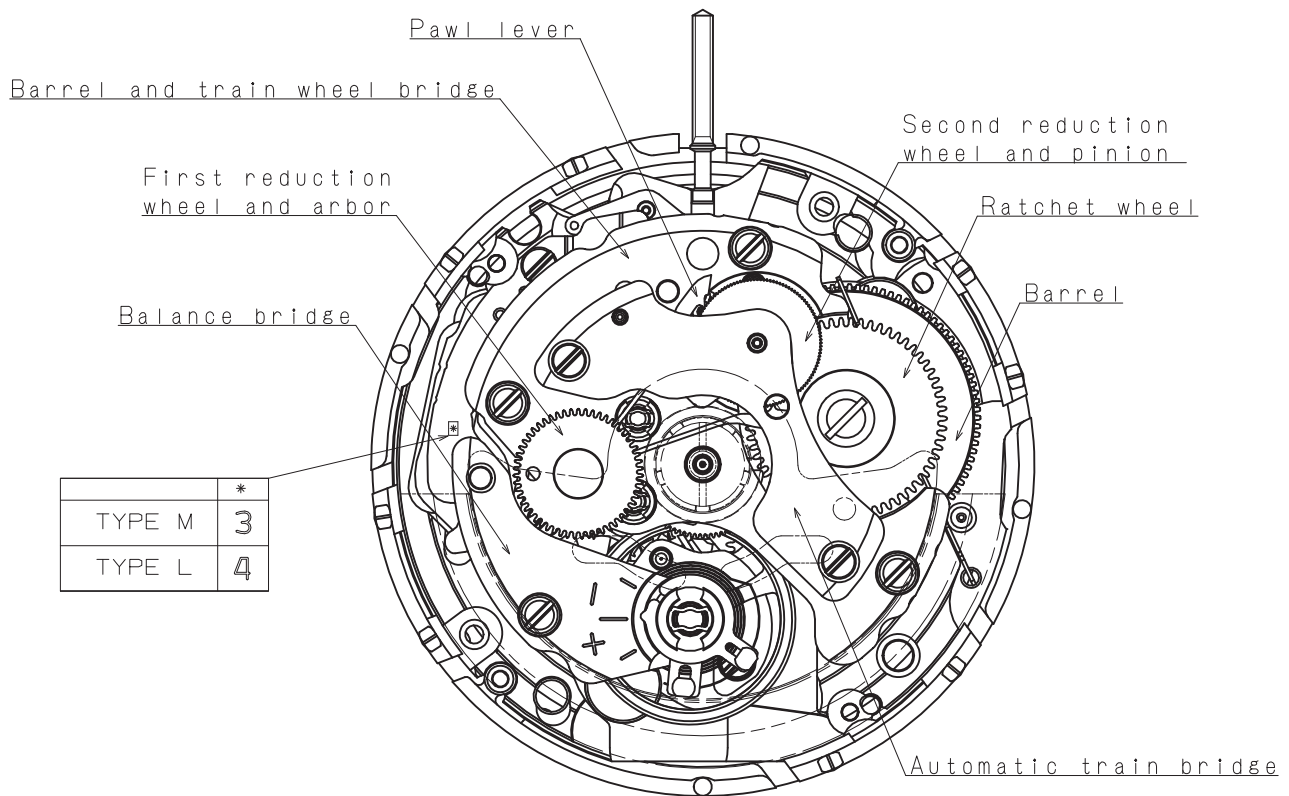

Oscillating weight

Marking	Country of origin
JAPAN	JAPAN
MALAYSIA	MALAYSIA

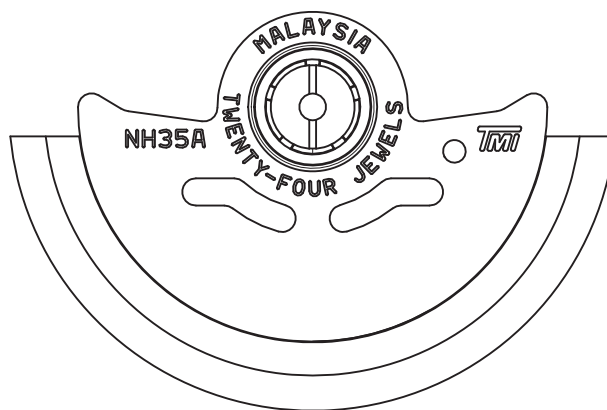
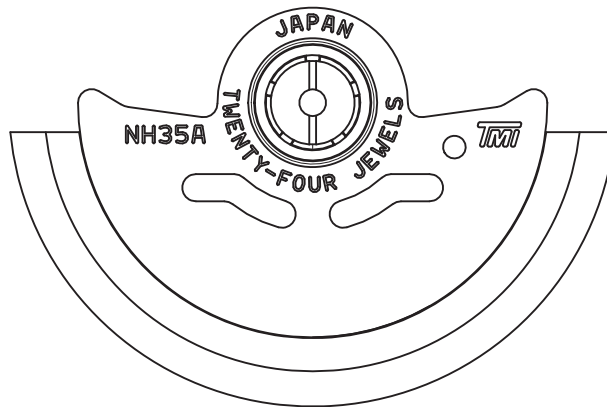

*1. First pull out stroke 39.9

*2. Second pull out stroke 40.0

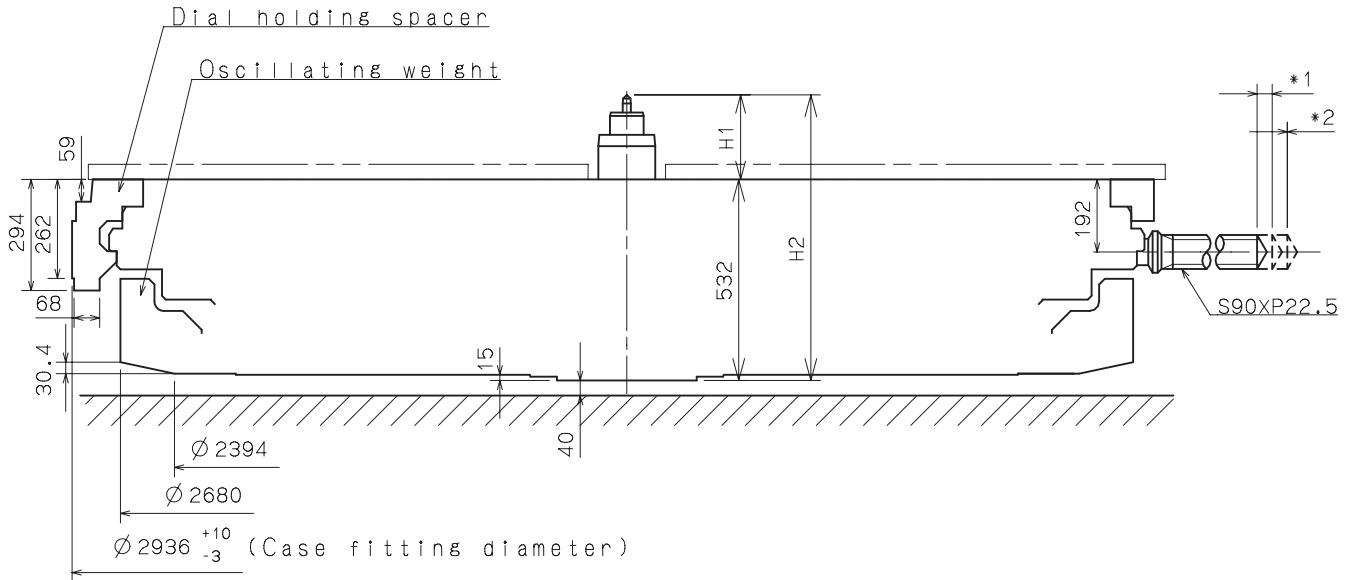

Center post 中心柱位		TYPE M 一般針高	TYPE L 高針
Maximum height from main plate surface 與機芯平面的最大高度	H1	226.7	266.7
Total height incl. movement 機芯總高度	H2	758.7	798.7

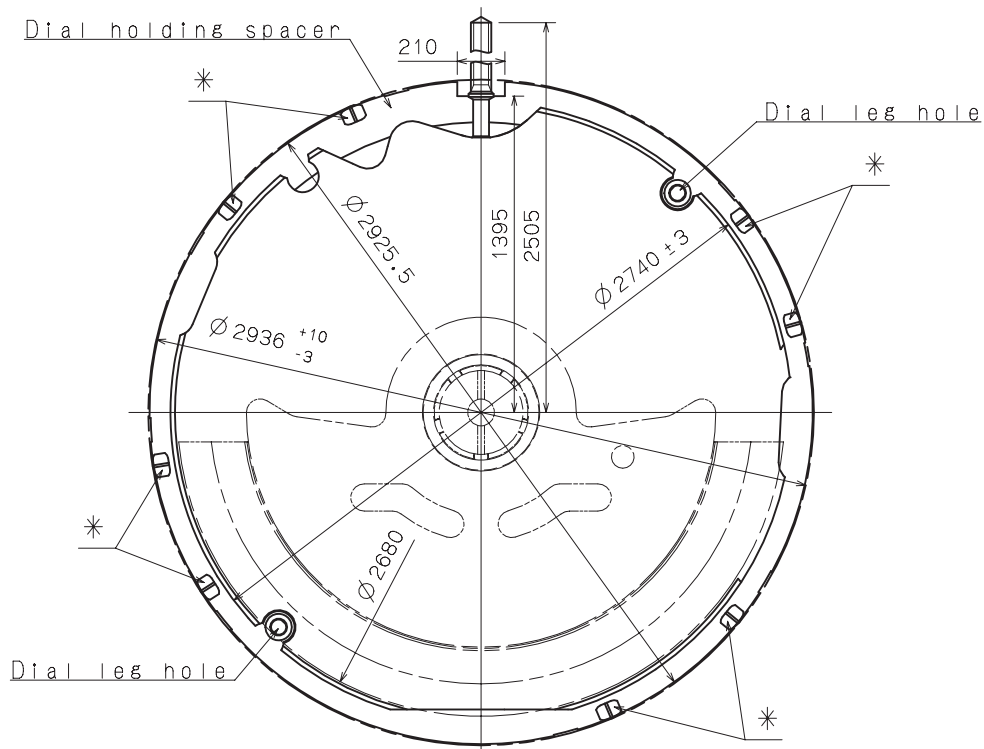

*Projection to fix movement to case.

Hour hand unbalance $\leq 1.50\mu\text{N}\cdot\text{m}$ (150mg·mm)
 Minute hand unbalance $\leq 1.25\mu\text{N}\cdot\text{m}$ (125mg·mm)
 Second hand unbalance $\leq 0.60\mu\text{N}\cdot\text{m}$ (60mg·mm)

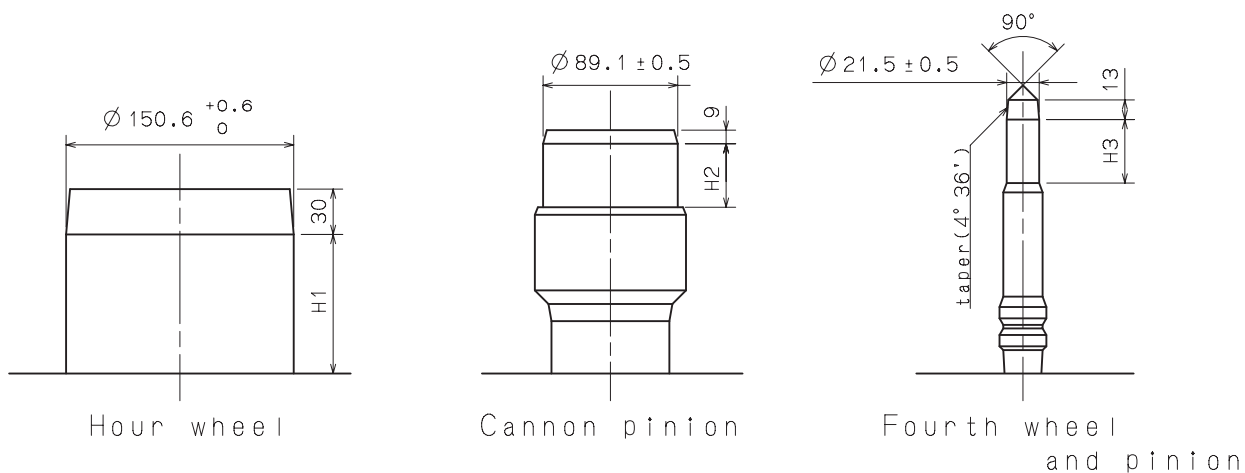

	Part No.			Dimension		
	Hour wheel 時針輪	Cannon pinion 分針輪(十反)	Fourth wheel and pinion 秒針輪	H1	H2	H3
TYPE M 一般針高	0273 182	0225 425	0144 184	88	61	42
TYPE L 高針	0273 184	0225 426	0144 185	128	61	42

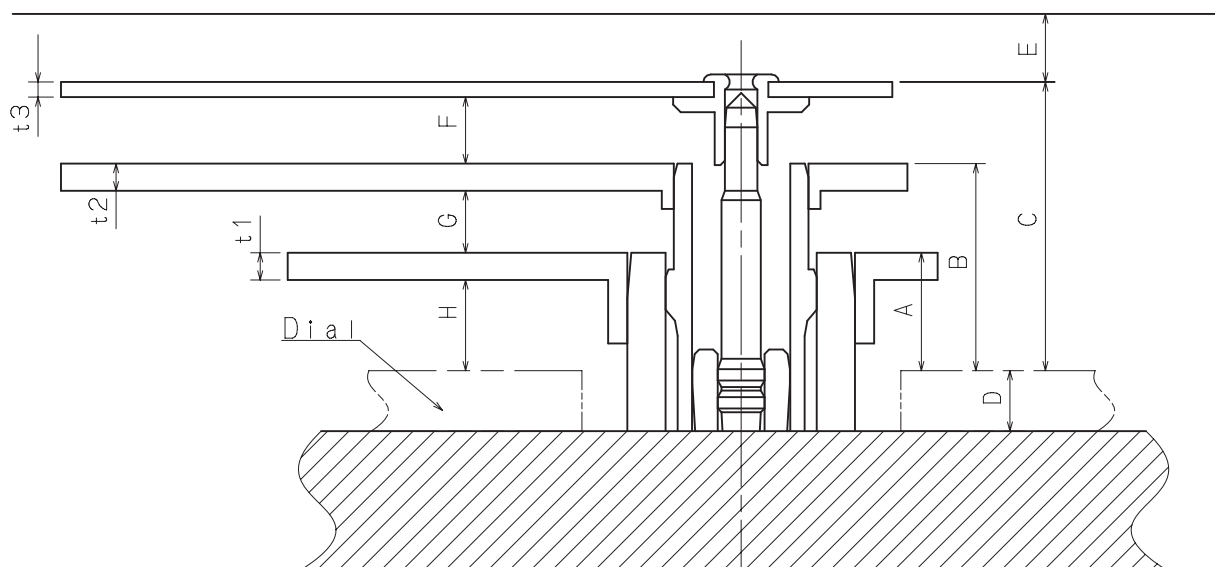

	A	B	C	D	E	F	G	H	t1	t2	t3
TYPE M 一般針高	78	137	191	40	45	44	41	60	18	18	10
TYPE L 高針	118	177	231	40	45	44	41	100	18	18	10

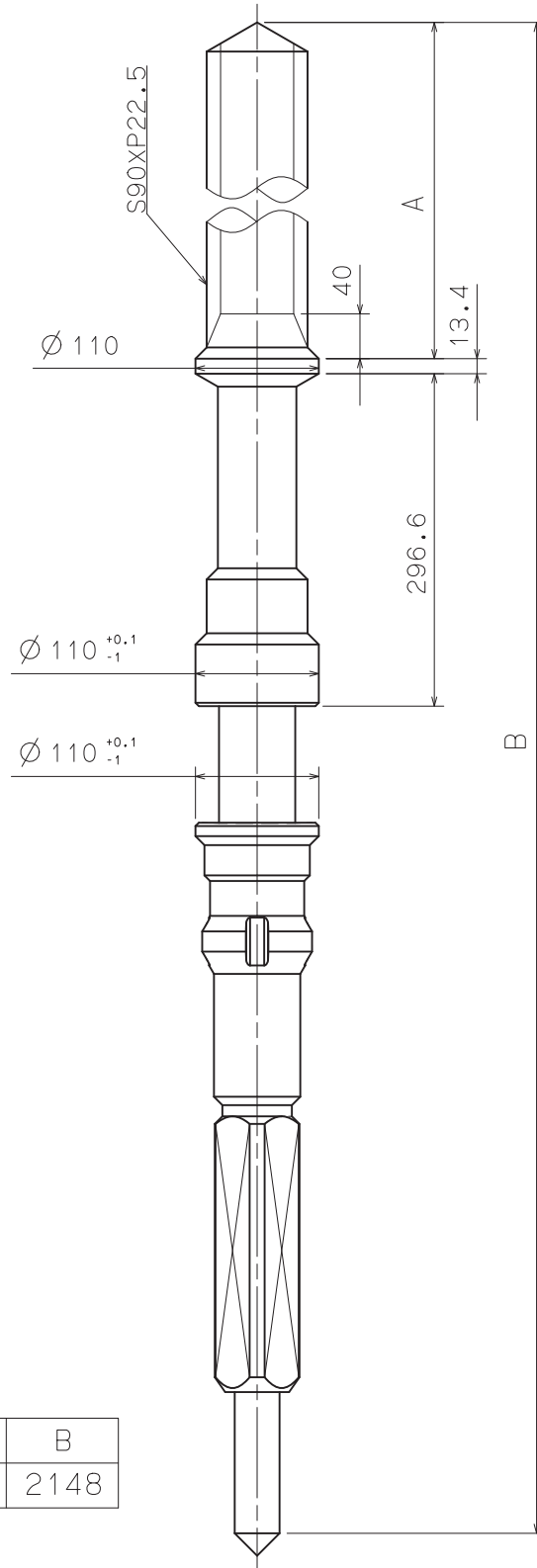

Part No.	A	B
0351 200	1100	2148

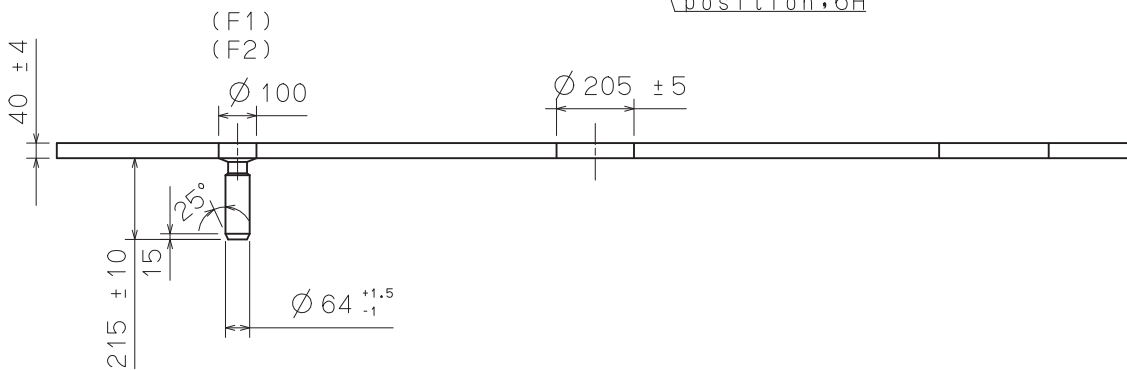
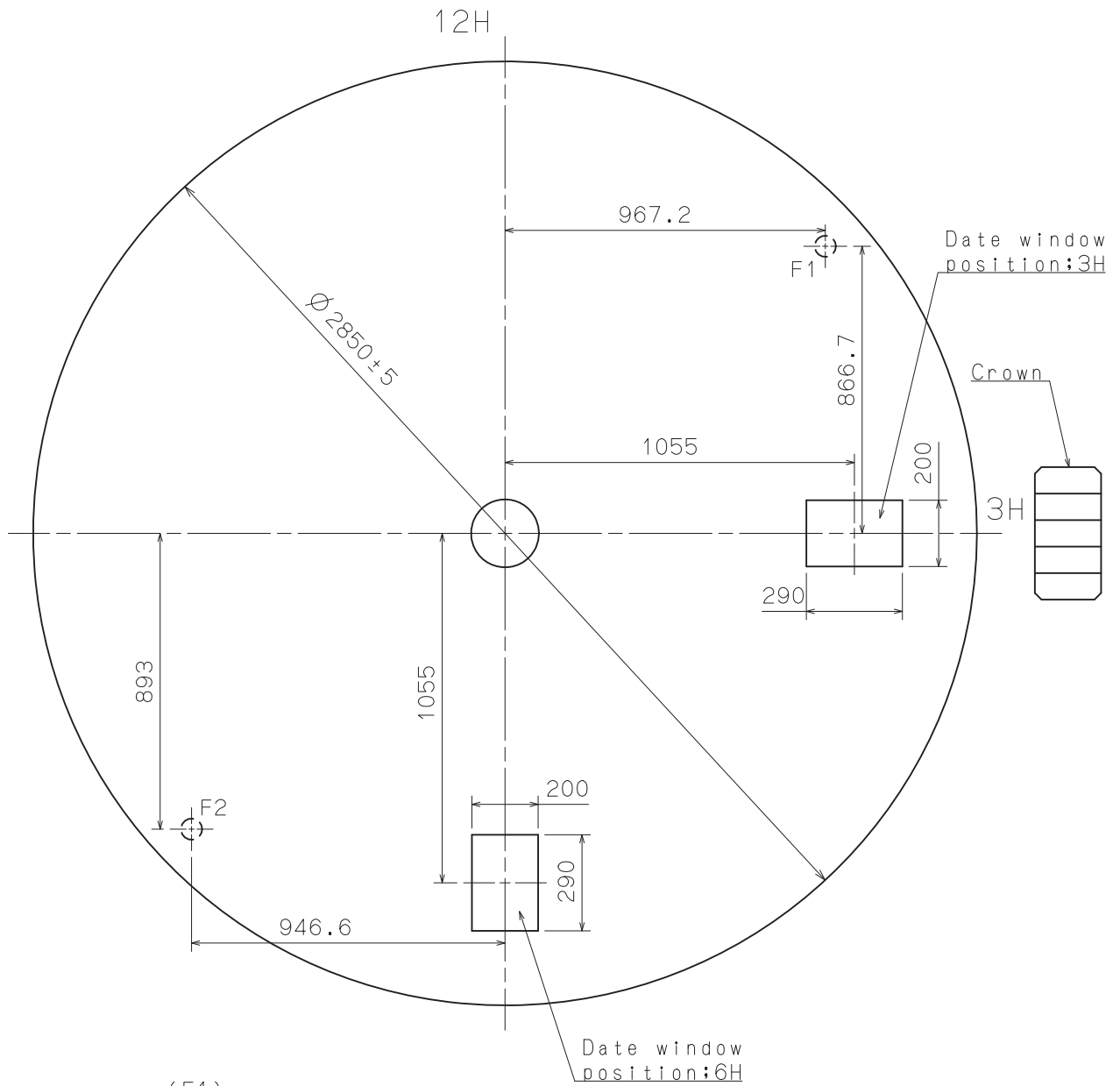

Assembly Plan

NH35A

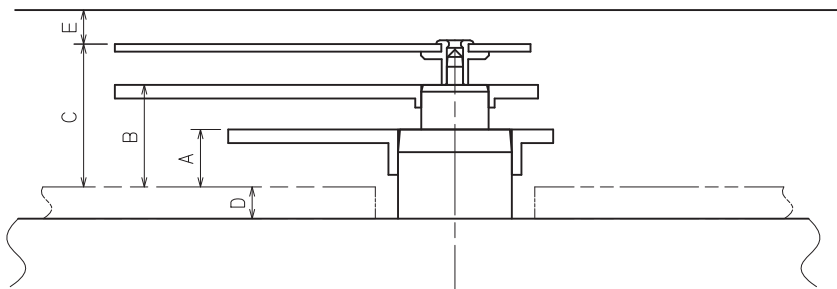
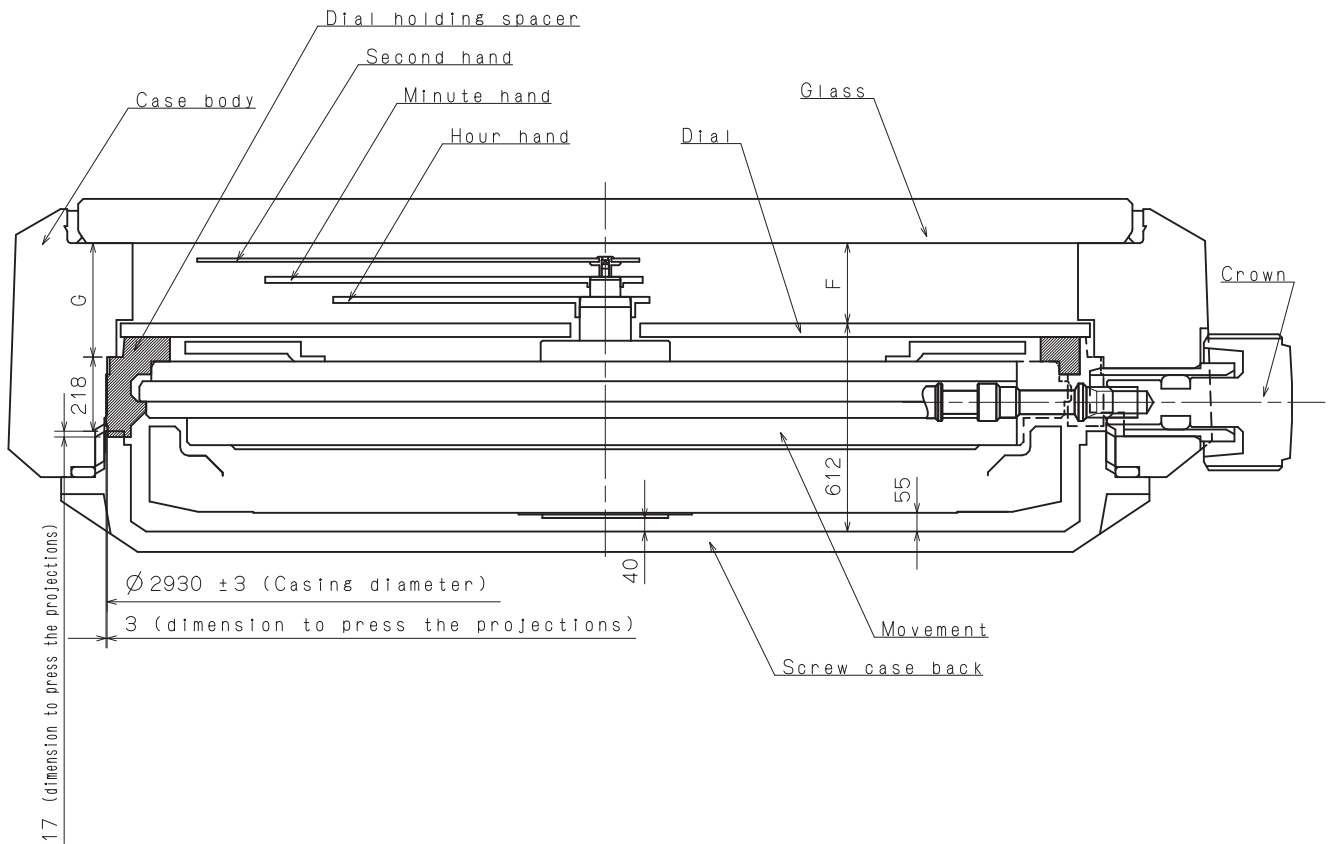

	A	B	C	D	E	F	G
TYPE M	78	137	191	40	45	236	335
TYPE L	118	177	231	40	45	276	375

Unit : 1=1/100mm

Version : 1

