

RONDA startech 5000

Chronographs, Big Date & Date,
different calendar systems, Alarm

Caliber 5050.B – 12½'''

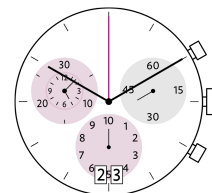

Product Specifications

Analog quartz movement

Line startech

Caliber 5050.B

Size 12½'''

Version Swiss Made 13 Jewels / gold plated
Swiss Parts 6 Jewels / nickel plated

Standard battery life 54 months

Hand fitting height 2

Features

- Very long battery life
- Repairable metal watch movement
- Power saving mechanism with pulled out stem: Reduction of consumption approximately 70%
- Very easy handling by two pushers

Functions

- Chronograph
- Center stop second (1/1 sec)
- 1/10 second
- 30 minute / 12 hour counter
- ADD and SPLIT functions
- 3 eyes
- Big date
- Small second

Technical Specifications

Diameter Total	28.60 mm
Case fitting	28.00 mm
Movement height	4.40 mm
Height over standard battery	4.40 mm
Movement rest	0.60 mm
Height over stem	1.90 mm
Length of stem travel	0.90 mm
Stem thread	0.90 mm
Standard battery	395
Standard battery life	54 months
Battery voltage	1.5 V
Current consumption – typical	1.32 µA (Date Mechanism not in Gear)
Current consumption – maximum	1.65 µA (Date Mechanism not in Gear)
Useful torque second – typical	6 µNm
Useful torque minute – typical	300 µNm
Useful torque center stop second – typical	7 µNm
Operating temperature	0 - 50 °C
Instantaneous rate	-10/ +20 sec/month
Resistance to magnetic fields	18.8 Oe
Resistance against shock	NIHS 91-10



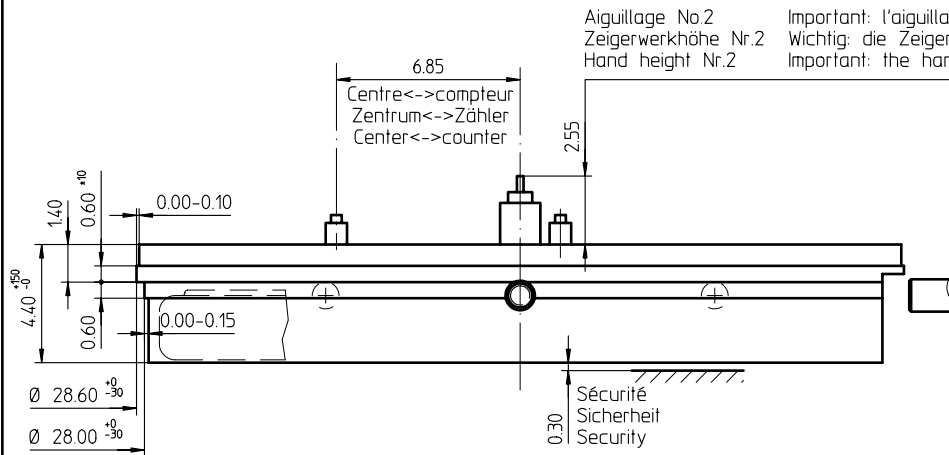

Côté fond de boîte
Seite Gehäuseboden
Case back side

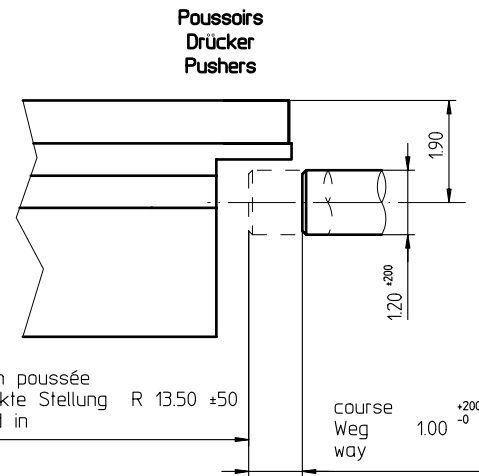

Sécurité entre l'aiguille des secondes et le verre:
Sicherheit zwischen Sekundenzeiger und Glas: 0.30mm
Security between second hand and glass:

Le cadran doit être tenu par la boîte
Das Zifferblatt muss durch die Schale gehalten werden
The dial must be hold by the case

La course du poussoir doit être limitée dans le poussoir lui-même. Sa position poussée doit être contrôlée.
Die Weglänge des Drückers ist im Drücker selbst zu begrenzen. In der gedrückten Stellung ist seine Position zu kontrollieren
The way of the pusher has to be limited in the pusher itself. Its position must be checked while pushed in.

Pile
Batterie (395) Ø 9.50 x 2.60mm
Battery

Position pour extraire la tige
Position zum Entfernen der Stellwelle
Position to remove the stem

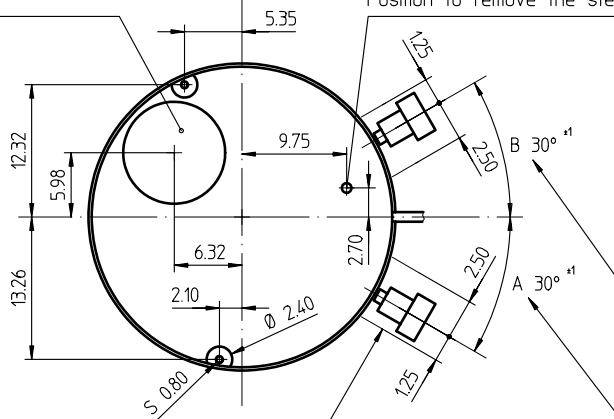

Dégagement cercle d'entourage
Freistellung Gehäuseering
Opening movement holder

L'angle indiqué pour la direction du poussoir et la position doivent être respectés. Pour un angle de 0° des poussoirs A et B, voir plan 5000.345
Der angegebene Winkel für die Drückerrichtung und die Position müssen eingehalten werden. Für einen Drückerwinkel von 0° bei A und B, siehe Zeichnung 5000.345
The indicated angle of the pusher direction and the position must be fulfilled. For pusher angles of 0° (pusher A and B), see drawing 5000.345

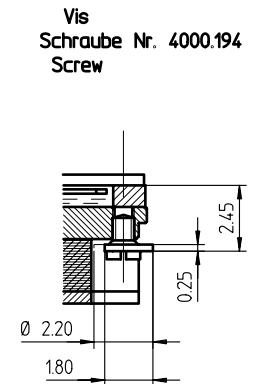
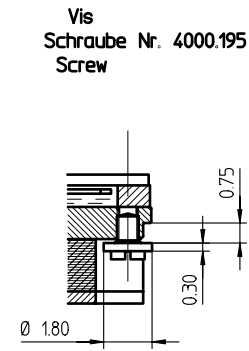
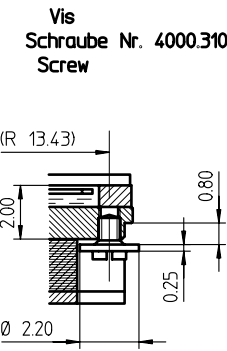
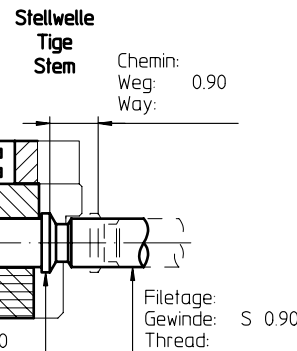

Cage Uhrwerkgestell Frame	12½"	Issued	14 Nov 2003	mk
		Modified	10. Dez 2007 AA 3696	bk
		Released	YES	
		Tolerance	+/- 20 µm	
		Scale	10 : 1 (5 : 1) (A3H)	
RONDA	5050.B, 5050.C, 5051.C	Sous réserve de modifications Änderungen vorbehalten Modifications reserved		
		No.	5000.319	03

Angle Winkel Angle		30°
Ø Dp	b	
1.00	13.50	
1.10	13.50	
1.20	13.50	
1.30	13.50	
1.40	13.50	

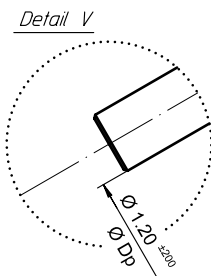
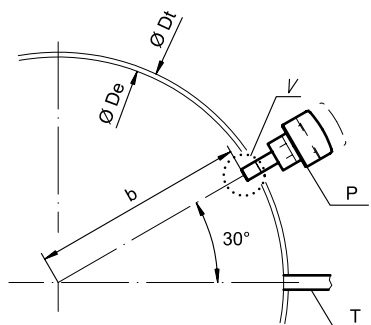

Angle Winkel Angle			0°
Ø Dp	a	b	
1.30	7.40	11.43	
1.40	7.45	11.40	

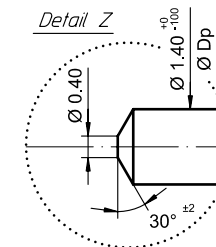
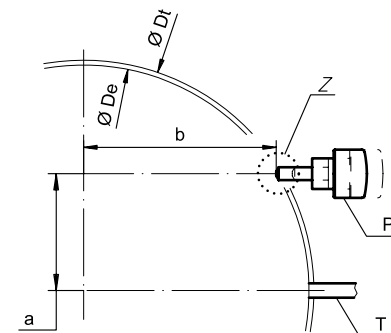

Angle Winkel Angle			20°
Ø Dp	a	b	
1.30	2.57	13.22	
1.40	2.59	13.21	

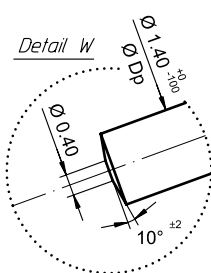
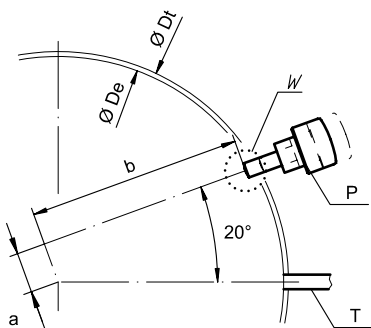

Ø De: diamètre d'encastage
Durchmesser der Gehäusepassung
fitting-diameter

Ø Dp: diamètre du poussoir
Drückerdurchmesser
pusher-diameter

Ø Dt: diamètre total
Totaldurchmesser
total-diameter

P: poussoir en position poussée
Drücker in gedrückter Stellung
pusher in pressed position

T: tige de mise à l'heure
Stellwelle
stem

Angle Winkel Angle			15°
Ø Dp	a	b	
1.30	3.83	12.92	
1.40	3.86	12.91	

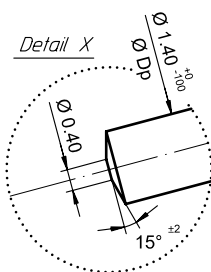
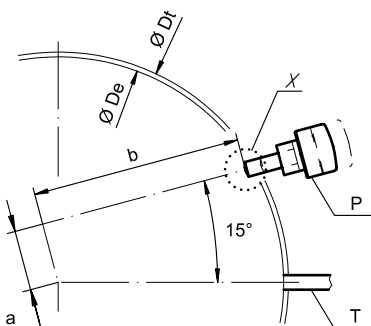

Angle Winkel Angle			10°
Ø Dp	a	b	
1.30	5.06	12.52	
1.40	5.10	12.50	

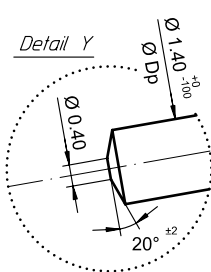
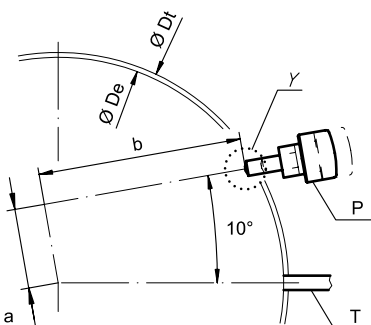

Angle des poussoirs A et B
Winkel der Drücker A und B
Angle of pusher A and B

RONDA 4xxx.x, 5xxx.x

Issued	06 Sep 2004	mk
Modified	30. März 2005 ÄÄ 1784	mk
Released	YES	
Tolerance	+/- 20 µm	
Scale	10 : 1 (5 : 1) (A3H)	

Sous réserve de modifications
Änderungen vorbehalten
Modifications reserved

No. 5000.345 01

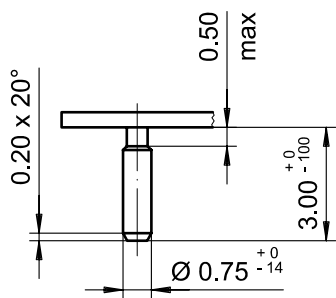
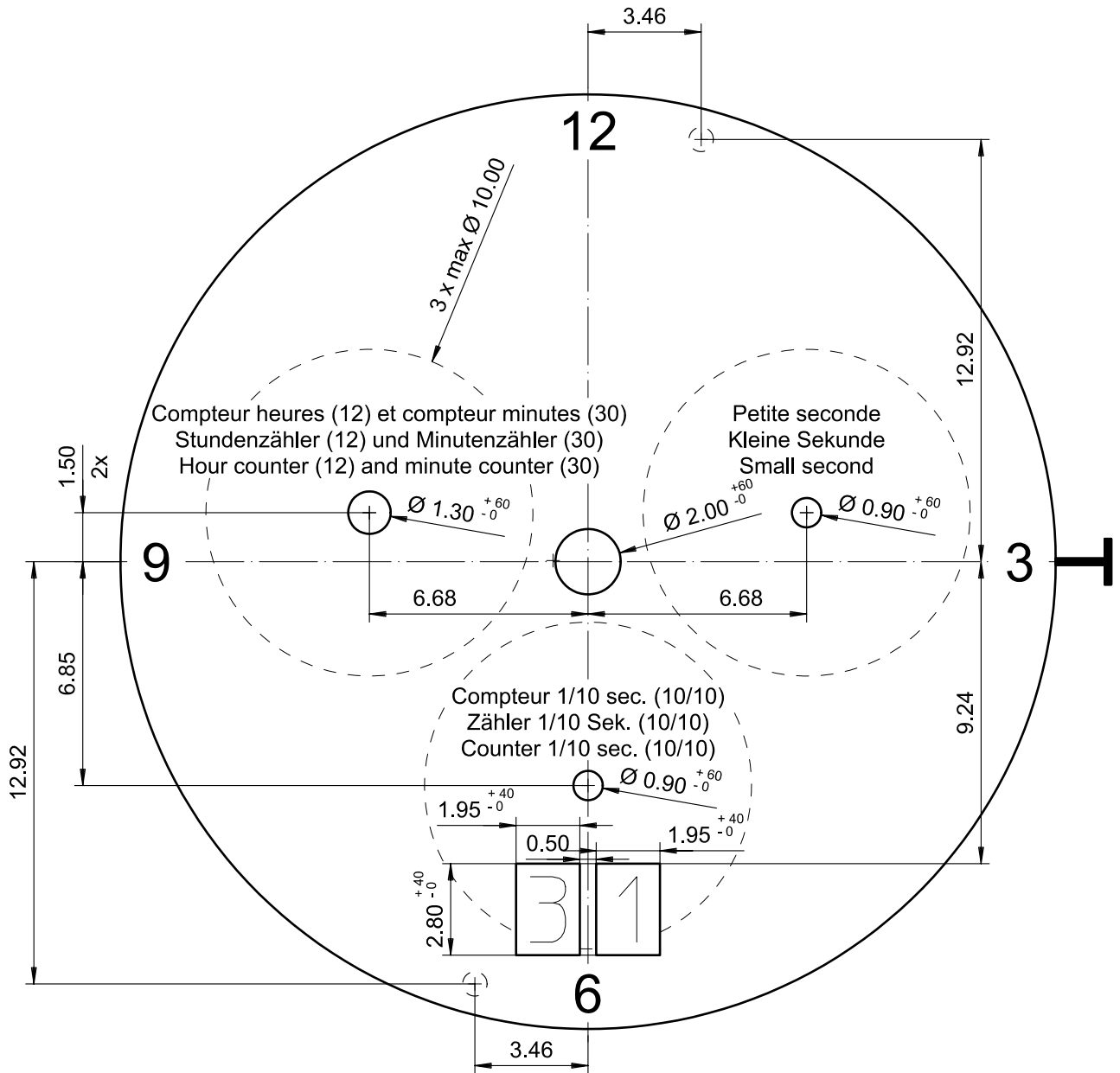

Epaisseur du cadran selon hauteur de l'aiguillage
 Zifferblattdicke gemäss Zeigerwerkhöhen
 Dial thickness according to hand fitting heights

Tige	Date
Stellw.	Datum
Stem	Date
3H	6H
	<input type="checkbox"/>

Cadran
 Zifferblatt
 Dial

12½"

Issued	13 Dez 2006	cw
Modified	15.Dez.2006 ÄA ----	cm
Released	YES	
Tolerance	+/- 20 µm	
Scale	5 : 1 (A4V)	

RONDA

5050.B

Sous réserve de modifications
 Aenderungen vorbehalten
 Modifications reserved

No. 5010.694 03

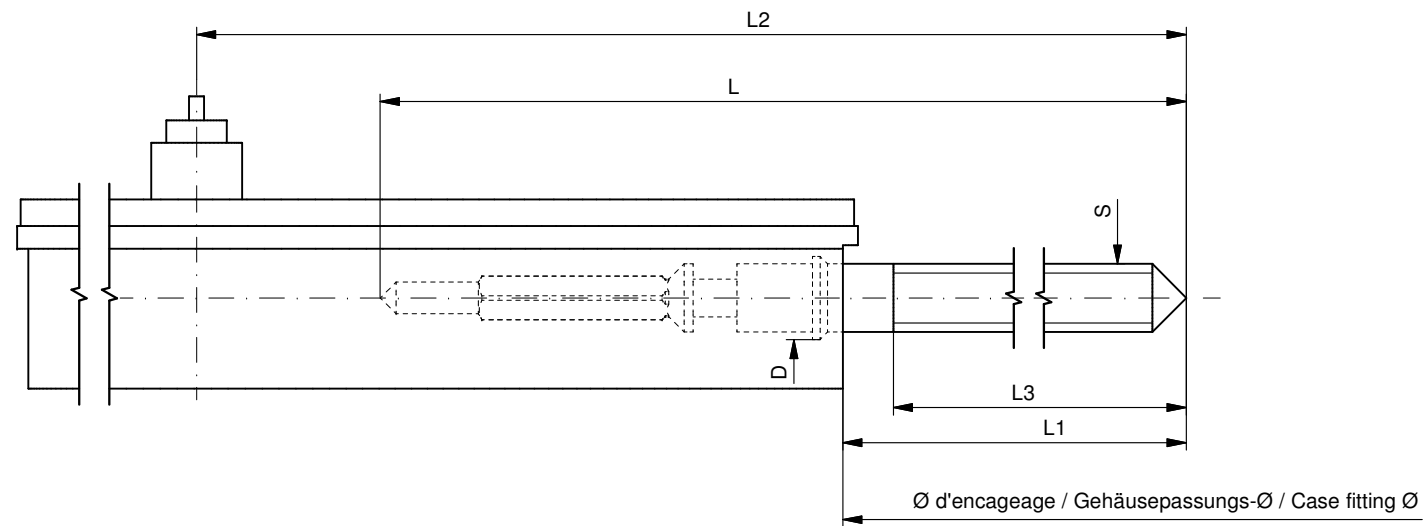

Tige de travail (intégrée dans le mouvement)
 Arbeitstellwelle (im Werk eingebaut)
 Working stem (implemented in the movement)

No. d'article Artikelnummer Part number	L	L1	L2	L3	S	D
3000.177.CO	20.00	10.23	24.23	10.15	0.90	1.10

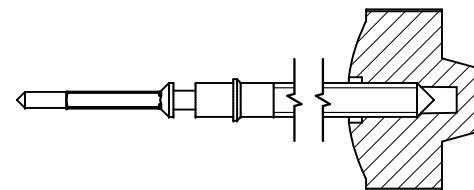

Couleur de la couronne Kronenfarbe Crown color	bleu foncé dunkelblau dark blue
Code	UN 5002

Tige (normale) / Stellwelle (normal) / Stem (normal)

No. d'article Artikelnummer Part number	L	L1	L2	L3	S	D
3000.177	20.00	10.23	24.23	10.15	0.90	1.10
3000.191	32.00	22.23	36.23	22.15	0.90	1.10

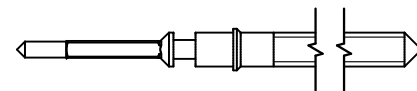

Couronne normale
 Normale Krone
 Normal crown

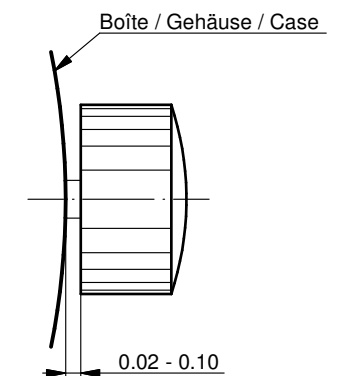

Couronne vissée
 Geschraubte Krone
 Screwed crown

Force ⇐ min. Kraft ⇐ min. Force ⇐ min.	10 N
Force ⇐ max. Kraft ⇐ max. Force ⇐ max.	15 N

Rallonge de tige / Stellwelle Verlängerung / Stem extension

No. d'article Artikelnummer Part number	L4	L5 (min)	L6	S1	S2	D1
3000.040	12.00	1.90	2.60	0.90	0.90	1.35

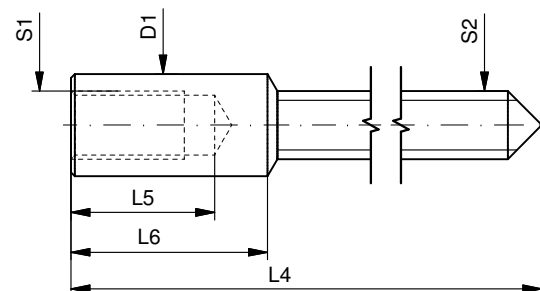

Tige (dimensions / forces)
 Stellwelle (Dimensionen / Kräfte)
 Stem (dimensions / forces)

RONDA

5010.B, 5020.B, 5021.D, 5030.D,
 5040.B, 5040.D, 5040.E, 5040.F,
 5050.B, 5050.C, 5051.C, 5130.B, 5130.D

Issued	05 Sep 2012	ds5222
Modified	17 Mär 2017 ÄA 34582	mg5224
Released	YES	
Tolerance	---	
Scale	10:1 (A3)	

Sous réserve de modifications
 Änderungen vorbehalten
 Modifications reserved

No.	5030.019	01
-----	----------	----

You have decided to buy a watch, which was assembled by a watchmaker using a Ronda movement. Please note that no watches are produced or distributed under the Ronda Brand.

In case of repairs, guarantee claims and questions concerning the functioning of a watch, purchasers and consumers should contact their retailer or the watch manufacturer, for which the relevant information can be found in the sales or guarantee documentation provided with the watch.

Description of the display and control buttons

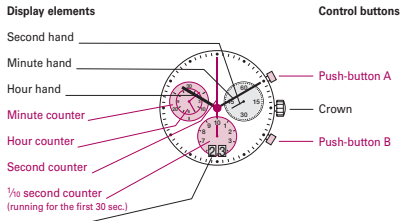

01

Chronograph: Basic function

(Start / Stop / Reset)

Example:

1 Start: Press push-button A.

2 Stop: to stop the timing, press push-button A once more and read the chronograph counters: 4h / 20 min / 38 sec / 1/5 sec

3 Zero positioning: Press push-button B. (The chronograph hands will be reset to their zero positions.)

05

Chronograph: Accumulated timing

Example:

1 Start: (start timing)

2 Stop: (e.g. 15 min 5 sec following 1)

3 Restart: (timing is resumed)

4 Stop: (e.g. 5 min 12 sec following 3) = 20 min 17 sec (The accumulated measured time is shown)

5 Reset: The chronograph hands are returned to their zero positions.

Please note:

* Following 4, the accumulation of the timing can be continued by pressing push-button A (Restart / Stop, Restart / Stop, ...).

06

Setting the time

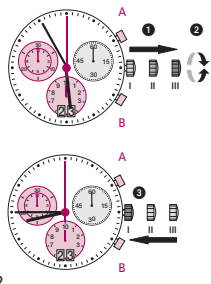

1* Pull out the crown to position III (the watch stops).

2 Turn the crown until you reach the correct time 8:45.

3* Push the crown back into position I.

Please note:
* In order to set the time to the exact second, 1 must be pulled out when the second hand is in position «60». Once the hour and minute hands have been set, 3 must be pushed back into position I at the exact second.

02

Chronograph: Intermediate or interval timing

Example:

1 Start: (start timing)

2 Display interval: (e.g. 20 minutes 17 seconds (timing continues in the background))

3 Making up the measured time: (The chronograph hands are quickly advanced to the ongoing measured time.)

4 Stop: (Final time is displayed)

5 Reset: The chronograph hands are returned to their zero position.

Please note:

* Following 4, further intervals or inter-mediate times can be displayed by pressing push-button B (display interval / make up measured time, ...).

07

Setting the date (quick mode)

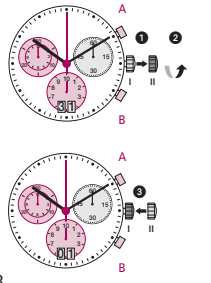

1 Pull out the crown to position II (the watch continues to run).

2 Turn the crown until the correct date appears.

3 Push the crown back into position I.

Please note:
During the date changing phase between approx. 9 PM and 12 PM; the date must be set to the date of the following day.
An extreme acceleration in setting the date with quick mode can induce a false date indication. The synchronization is re-established by setting the date from 01 till 31 (crown in position II).

03

Adjusting the chronograph hands to zero position

Example:

One or several chronograph hands are not in their correct zero positions and have to be adjusted (e.g. following a battery change).

1 Pull out the crown to position III (all chronograph hands are in their correct or incorrect zero position).

2 Keep push-buttons A and B depressed simultaneously for at least 2 seconds (the second counter hand rotates by 360° → corrective mode is activated).

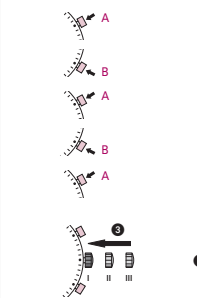

Adjusting the second counter hand

Single step: A 1 x short
Continuous: A long

Adjusting the next hand B

Single step: A 1 x short
Continuous: A long

Adjusting the 1/5 second counter hand (position 6h)

Single step: A 1 x short
Continuous: A long

Adjusting the next hand B

Single step: A 1 x short
Continuous: A long

Adjusting the minute counter hand and the hour counter hand (mechanical coupled)

Single step: A 1 x short
Continuous: A long

3 Returning the crown to position I
Termination of the chronograph hands adjustment (can be carried out at any time).

08

Setting the date/time

Example:
- Date / time on the watch: 17 / 1:25 AM
- Present date / time: 4 / 8:30 PM

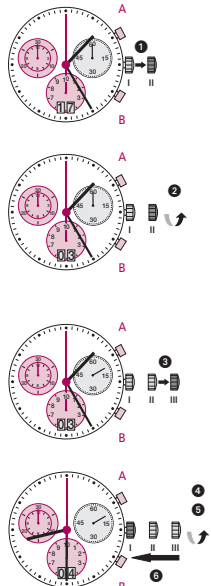

1 Pull out the crown to position II (the watch continues to run).

2 Turn the crown until yesterday's date appears.

3* Pull out the crown to position III (the watch stops).

4 Turn the crown until the correct date appears.

5** Continue to turn the crown until the correct time 8:30 PM appears.

6 Push the crown back into position I.

Please note:
* To set your watch to the exact second, please refer to the chapter entitled «setting the time».
** Please observe the AM/PM clock rhythm.

04



Battery type: 395 / SR927SW
Accuracy: +20 / -10 seconds per month

07/2017



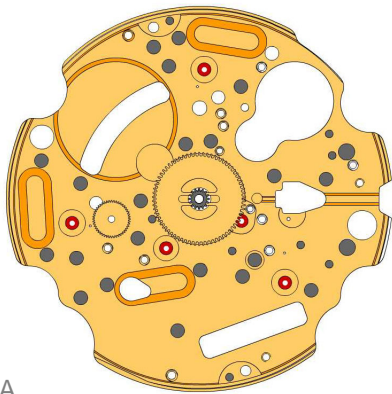



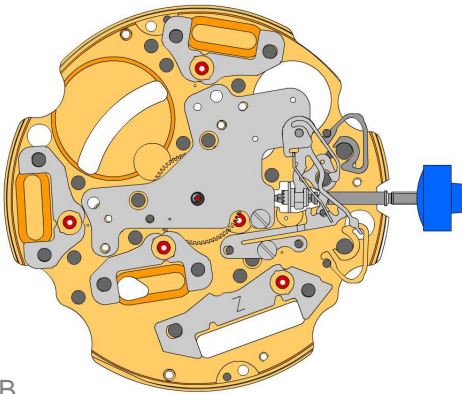





















A

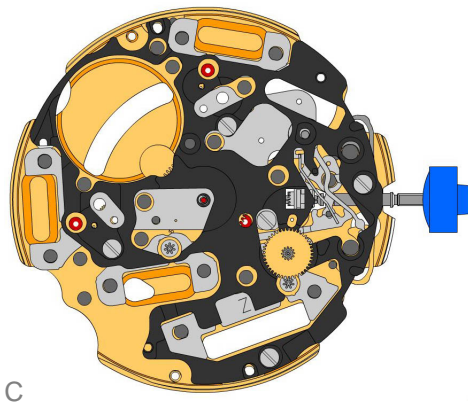





B

2000.574.G 1.		Main plate
3305.282.CO 2.		Cannon pinion with driver (Aig.2)
3301.244 3.		Hour wheel (counter 24h)
2030.017.CO 4.		Centre bridge Centre bridge held by 1 screw 4000.250. Parts 2030.017.CO, 3402.009.CO, 3004.223 and 3500.059 must be exchanged together.
4000.250 5.		Screw
3001.055.FI 6.		Sliding pinion
3000.177.CO 7.		Setting stem
3017.049 8.		Setting lever
3905.049 9.		Setting lever jumper (3 positions) Setting lever jumper held by 1 screw 4000.250.
4000.250 10.		Screw
3015.081 11.		Yoke (3 positions) Parts 3015.081 and 3905.067 must be exchanged together.
3905.067 12.		Yoke spring Tensioning the spring arm. Parts 3015.081 and 3905.067 must be exchanged together.
3406.030 13.		Pusher jumper B Put the grey jumper between the two posts on the further side.
3406.038 14.		Pusher jumper A Put the yellow jumper between the two posts on the closer side.
3622.040 15.		Stator Mark Z on stator.
3622.039 16.		Stator (counter 6h, 9h, chrono)
3622.039 17.		Stator (counter 6h, 9h, chrono)
3622.039 18.		Stator (counter 6h, 9h, chrono)

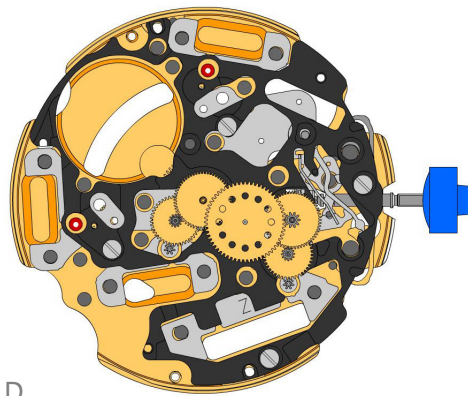



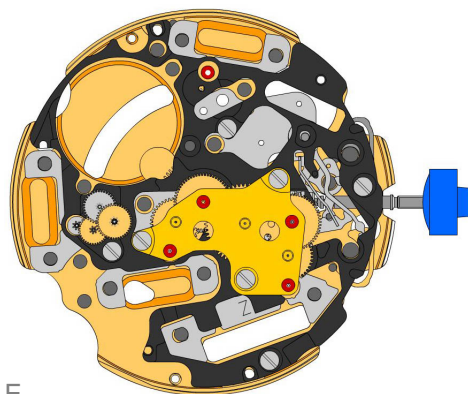

C

3603.079 19.		Plastic bracket Plastic bracket held by 4 screws 4000.250.
4000.250 20.		Screw
3715.094.RK 21.		Rotor
3715.094.RK 22.		Rotor
3147.046.CO 23.		Intermediate wheel

D





3136.142.CO 24.		Second wheel (long)
3147.047.CO 25.		Intermediate wheel (chrono)
3136.144.CO 26.		Chronograph wheel (Aig.2)
3122.056.CO 27.		Third wheel

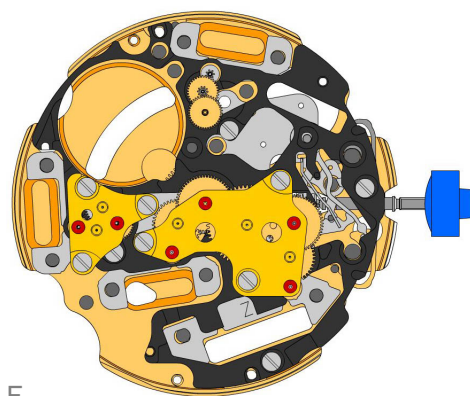

E

2020.148.G 28.		Train wheel bridge Train wheel bridge held by 3 screws 4000.250.
4000.250 29.		Screw
3715.095.RK 30.		Rotor
3147.048.CO 31.		Intermediate wheel (counter)
3007.056.CO 32.		Minute wheel (counter 24h)
3402.008.CO 33.		Minute counting wheel





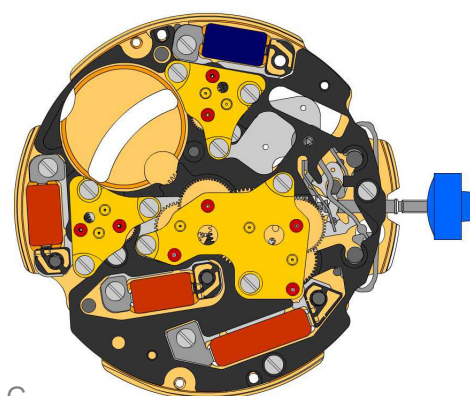







F

2020.149.G 34.		Counter train wheel bridge Counter train wheel bridge held by 3 screws 4000.250.
4000.250 35.		Screw
3715.095.RK 36.		Rotor
3147.053.CO 37.		Intermediate wheel (counter 1/10sec)
3402.009.CO 38.		Counting wheel 1/10 sec Parts 2030.017.CO, 3402.009.CO, 3004.223 and 3500.059 must be exchanged together.





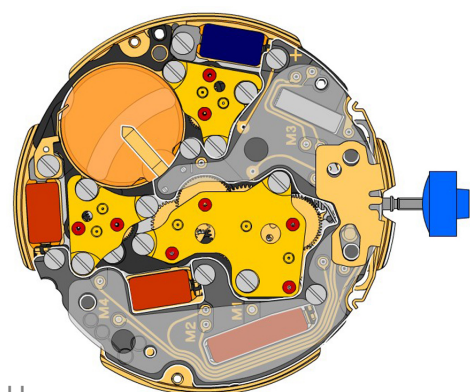

G

2020.149.G 39.		Counter train wheel bridge Counter train wheel bridge held by 3 screws 4000.250.
4000.250 40.		Screw
3621.053.RK 41.		Coil Attention: Please hold the coil only on the grey coil core. Coil held by 1 screw 4000.250.
3621.054.RK 42.		Coil (counter 9h, chrono) Attention: Please hold the coil only on the grey coil core. Coil held by 1 screw 4000.250.
3621.054.RK 43.		Coil (counter 9h, chrono) Attention: Please hold the coil only on the grey coil core. Coil held by 1 screw 4000.250.
3621.055.RK 44.		Coil (counter 6h) Attention: Please hold the coil only on the grey coil core. Coil held by 1 screw 4000.250.
4000.250 45.		Screw
3601.118 46.		Contact strip Contact strip held by 1 screw 4000.250.
4000.250 47.		Screw
3603.034 48.		Battery insulator



H

3612.144.5050 49.		Electronic module Electronic module held by 5 screws 4000.248. Electronic measurements may be realised now.
4000.248 50.		Screw
3603.069 51.		Circuit insulator
3601.107.G 52.		Pusher contact spring

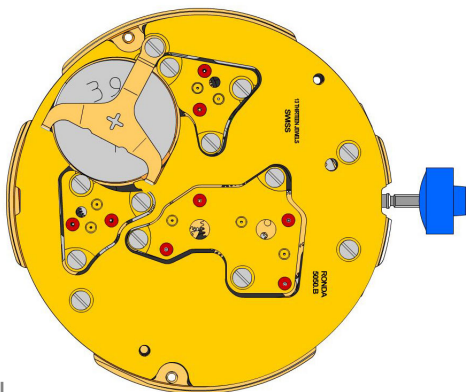





2130.137.G.M01.5050B
53.  **Electronic module cover**
Electronic module cover held by 3 screws 4000.250.

3600.010.HGF
54.  **Battery 395**

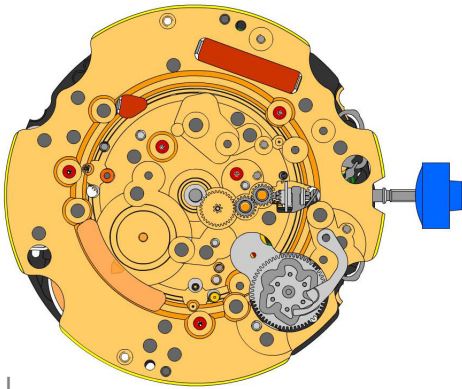







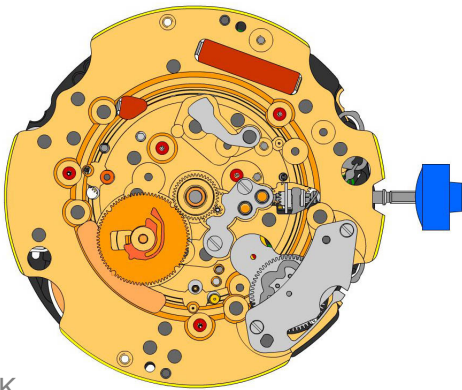

3601.109.G
55.  **Bridge +**
Bridge held by 1 screw 4000.250.

4000.250
56.  **Screw**

J

2000.574.G 57.		Main plate
3004.164 58.		Setting wheel
3004.164 59.		Setting wheel
3007.054.CO 60.		Minute wheel

K



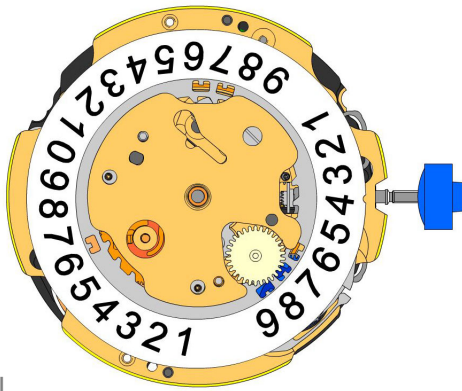

2130.143 61.		Minute train bridge Minute train bridge held by 2 screws 4000.305.
4000.305 62.		Screw
3004.223 63.		Tens indicator driving wheel Parts 2030.017.CO, 3402.009.CO, 3004.223 and 3500.059 must be exchanged together. The short tooth of the tens indicator driving wheel must point to the center of the movement.
3500.059 64.		Tens jumper Parts 2030.017.CO, 3402.009.CO, 3004.223 and 3500.059 must be exchanged together.
2130.142 65.		Tens jumper maintaining plate Tens jumper maintaining plate held by 2 screws 4000.306. Tensioning the spring arm.
4010.306 66.		Screw
3301.242 67.		Hour wheel (Fig.2)
3315.016 68.		Friction spring
3004.224.CO 69.		Date indicator driving wheel
3500.049 70.		Date jumper

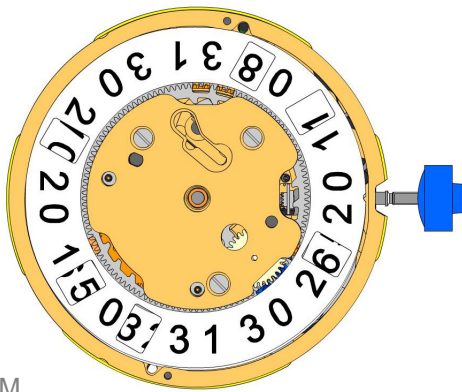









L



M

3504.214.AD.1.A 71.		Units indicator (standard) Nick of the indicator at 3 o'clock.
3147.054 72.		Tens intermediate wheel
2130.141 73.		Date indicator maintaining plate Date indicator maintaining plate held by 1 screw 4000.250.
3905.070 74.		Date jumper spring Insert the date jumper spring in the provided opening.

3504.215.AD.1.A 75.		Tens indicator (standard) Nick of the indicator at 3 o'clock.
2130.140.G 76.		Date mechanism maintaining plate Date mechanism maintaining plate held by 2 screws 4000.250.
4000.250 77.		Screw
3506.072.G 78.		Dial support

8200 79.		Moebius 8200
9014 80.		Moebius 9014
124 81.		Jismaa 124
9020 82.		Moebius 9020

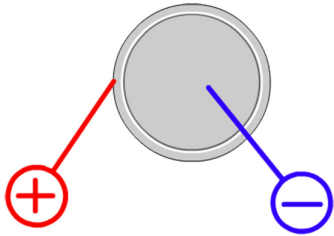

Battery	395
Voltage	1.55 V

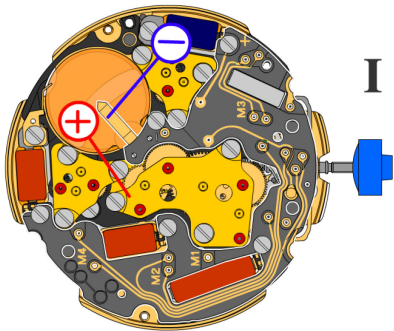

*Setting stem in position I, calendar not in gear,
60 s measuring interval for rate and consumption:*

Typical consumption	1.32 μA
Maximal consumption	1.65 μA
Rate	-10s/M. .. +20s/M.
Lower working voltage limit	1.20 V

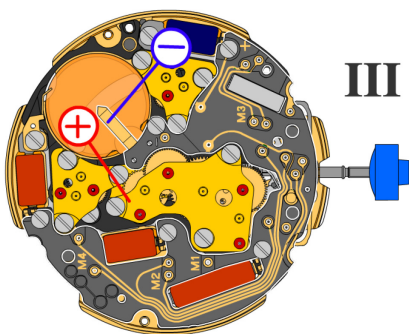

Setting stem in position III, 60 s measuring interval:

Typical consumption	0.10 μA
Maximal consumption	0.30 μA

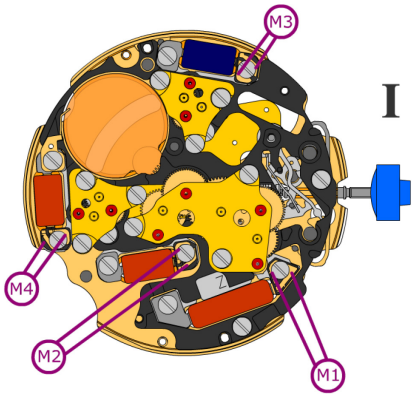

Coil resistance M1 **1.90 kΩ .. 2.10 kΩ**

Coil resistance M2 **1.68 kΩ .. 1.88 kΩ**

Coil resistance M3 **1.68 kΩ .. 1.88 kΩ**

Coil resistance M4 **1.68 kΩ .. 1.88 kΩ**

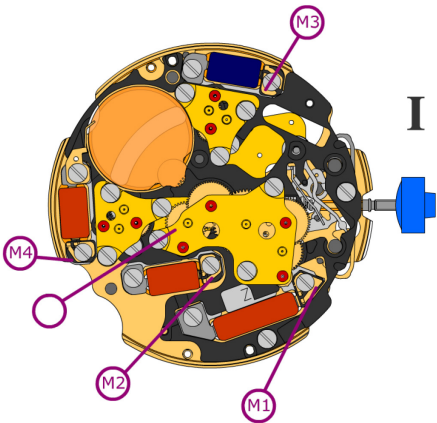

Coil isolation M1/M2/M3/M4 **∞ kΩ**

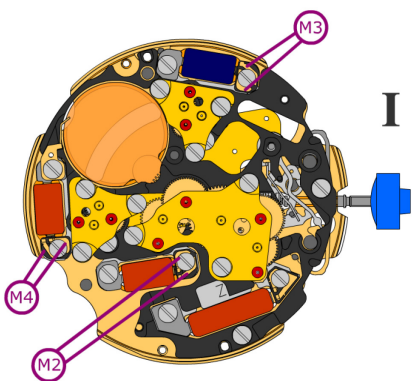

Signal generator (4.9 ms, 8 Hz):



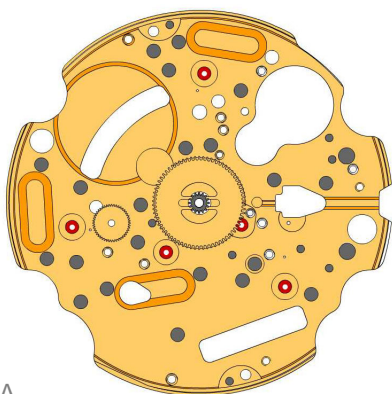



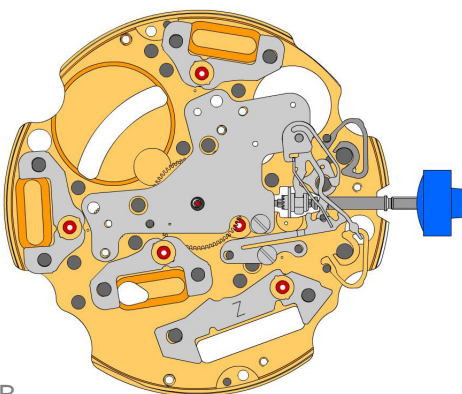











Lower working voltage limit
M2/M3/M4 **1.20 V**









A

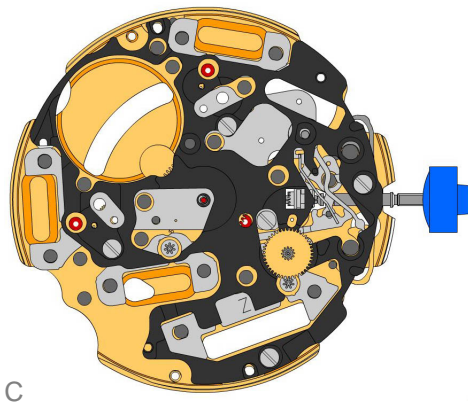





B

2000.574.G 1.		Main plate
3305.282.CO 2.		Cannon pinion with driver (Aig.2)
3301.244 3.		Hour wheel (counter 24h)
2030.032.CO 4.		Centre bridge Centre bridge held by 1 screw 4000.250.
4000.250 5.		Screw
3001.055.FI 6.		Sliding pinion
3000.177.CO 7.		Setting stem
3017.049 8.		Setting lever
3905.049 9.		Setting lever jumper (3 positions) Setting lever jumper held by 1 screw 4000.250.
4000.250 10.		Screw
3015.081 11.		Yoke (3 positions)
3905.067 12.		Yoke spring Tensioning the spring arm.
3406.030 13.		Pusher jumper B Put the grey jumper between the two posts on the further side.
3406.038 14.		Pusher jumper A Put the yellow jumper between the two posts on the closer side.
3622.040 15.		Stator Mark Z on stator.
3622.039 16.		Stator (counter 6h, 9h, chrono)
3622.039 17.		Stator (counter 6h, 9h, chrono)
3622.039 18.		Stator (counter 6h, 9h, chrono)

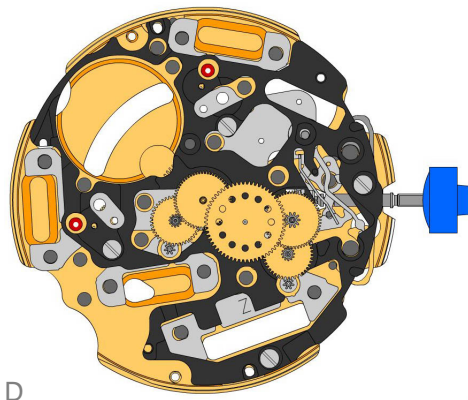





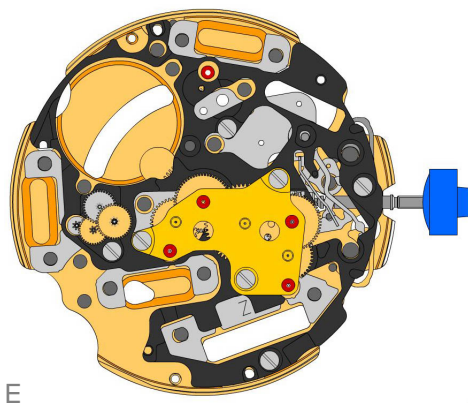

3603.079 19.		Plastic bracket Plastic bracket held by 4 screws 4000.250.
4000.250 20.		Screw
3715.094.RK 21.		Rotor
3715.094.RK 22.		Rotor
3147.046.CO 23.		Intermediate wheel







3136.142.CO 24.		Second wheel (long)
3147.047.CO 25.		Intermediate wheel (chrono)
3136.144.CO 26.		Chronograph wheel (Aig.2)
3122.056.CO 27.		Third wheel

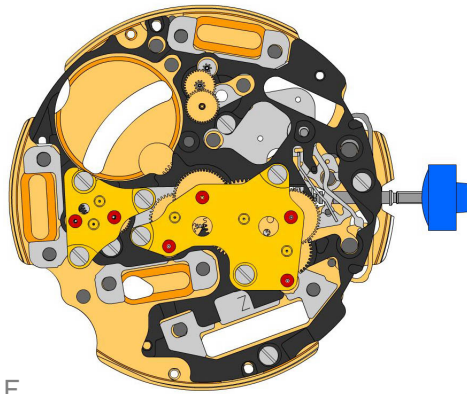







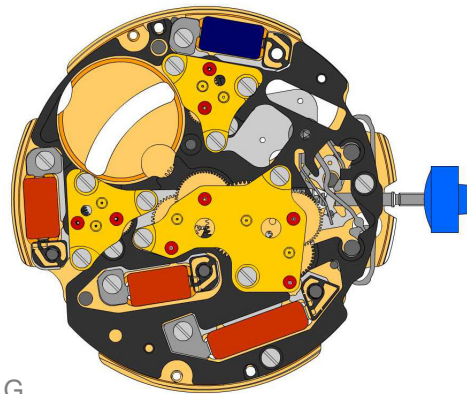



2020.148.G 28.		Train wheel bridge Train wheel bridge held by 3 screws 4000.250.
4000.250 29.		Screw
3715.095.RK 30.		Rotor
3147.048.CO 31.		Intermediate wheel (counter)
3007.056.CO 32.		Minute wheel (counter 24h)
3402.008.CO 33.		Minute counting wheel





F

2020.149.G 34.		Counter train wheel bridge Counter train wheel bridge held by 3 screws 4000.250.
4000.250 35.		Screw
3715.095.RK 36.		Rotor
3147.053.CO 37.		Intermediate wheel (counter 1/10sec)
3402.016.CO 38.		Counting wheel 1/10 sec

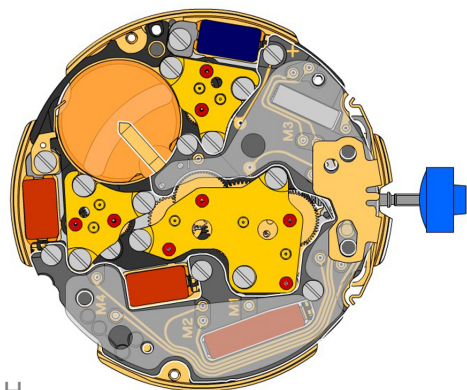
G

2020.149.G 39.		Counter train wheel bridge Counter train wheel bridge held by 3 screws 4000.250.
4000.250 40.		Screw
3621.053.RK 41.		Coil Attention: Please hold the coil only on the grey coil core. Coil held by 1 screw 4000.250.
3621.054.RK 42.		Coil (counter 9h, chrono) Attention: Please hold the coil only on the grey coil core. Coil held by 1 screw 4000.250.
3621.054.RK 43.		Coil (counter 9h, chrono) Attention: Please hold the coil only on the grey coil core. Coil held by 1 screw 4000.250.
3621.055.RK 44.		Coil (counter 6h) Attention: Please hold the coil only on the grey coil core. Coil held by 1 screw 4000.250.
4000.250 45.		Screw
3601.118 46.		Contact strip Contact strip held by 1 screw 4000.250.
4000.250 47.		Screw
3603.034 48.		Battery insulator

H

3612.144.5050 49.		Electronic module Electronic module held by 5 screws 4000.248. Electronic measurements may be realised now.
4000.248 50.		Screw
3603.069 51.		Circuit insulator
3601.107.G 52.		Pusher contact spring

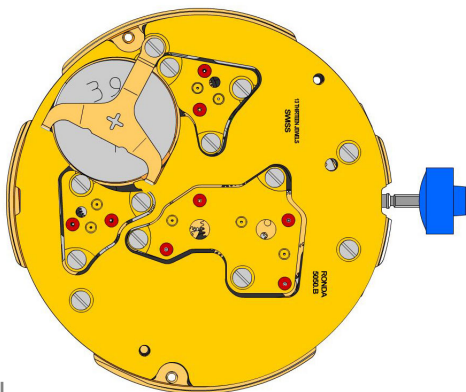





2130.137.G.M01.5050B
53.  **Electronic module cover**
Electronic module cover held by 3 screws 4000.250.

3600.010.HGF
54.  **Battery 395**

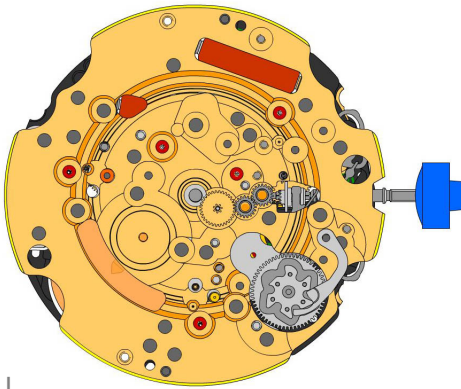







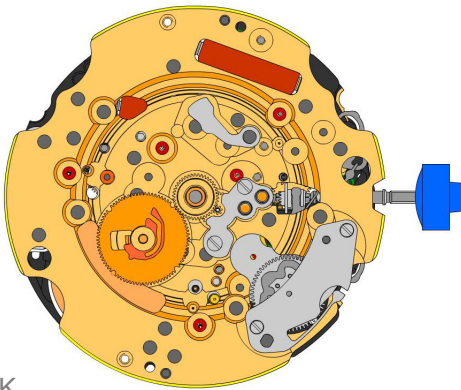

3601.109.G
55.  **Bridge +**
Bridle held by screw 4000.250.

4000.250
56.  **Screw**

J

2000.574.G 57.		Main plate
3004.164 58.		Setting wheel
3004.164 59.		Setting wheel
3007.054.CO 60.		Minute wheel

K



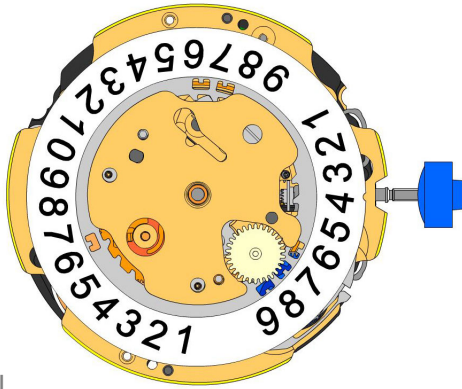

2130.143 61.		Minute train bridge Minute train bridge held by 2 screws 4000.305.
4000.305 62.		Screw
3004.227 63.		Tens indicator driving wheel Parts 3004.227 and 3500.075 must be exchanged together. The short tooth of the tens indicator driving wheel must point to the center of the movement.
3500.075 64.		Tens jumper Parts 3004.227 and 3500.075 must be exchanged together.
2130.142 65.		Tens jumper maintaining plate Tens jumper maintaining plate held by 2 screws 4000.306. Tensioning the spring arm.
4010.306 66.		Screw
3301.242 67.		Hour wheel (Fig.2)
3315.016 68.		Friction spring
3004.224.CO 69.		Date indicator driving wheel
3500.049 70.		Date jumper

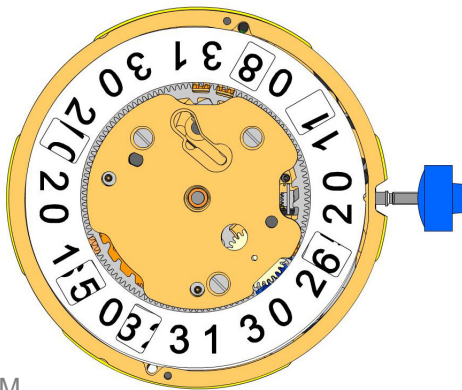









L



M

3504.214.AD.1.A 71.		Units indicator (standard) Nick of the indicator at 3 o'clock.
3147.054 72.		Tens intermediate wheel
2130.141 73.		Date indicator maintaining plate Date indicator maintaining plate held by 1 screw 4000.250.
3905.070 74.		Date jumper spring Insert the date jumper spring in the provided opening.

3504.215.AD.1.A 75.		Tens indicator (standard) Nick of the indicator at 3 o'clock.
2130.140.G 76.		Date mechanism maintaining plate Date mechanism maintaining plate held by 2 screws 4000.250.
4000.250 77.		Screw
3506.072.G 78.		Dial support

8200 79.		Moebius 8200
9014 80.		Moebius 9014
124 81.		Jismaa 124
9020 82.		Moebius 9020

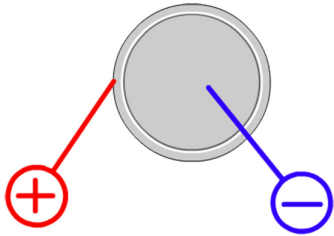

Battery	395
Voltage	1.55 V

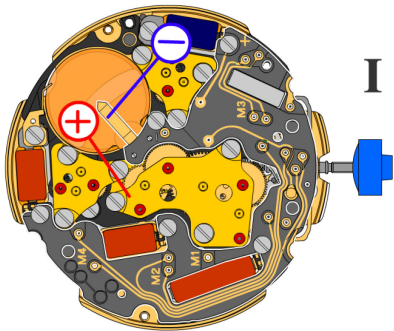

*Setting stem in position I, calendar not in gear,
60 s measuring interval for rate and consumption:*

Typical consumption	1.32 μA
Maximal consumption	1.65 μA
Rate	-10s/M. .. +20s/M.
Lower working voltage limit	1.20 V

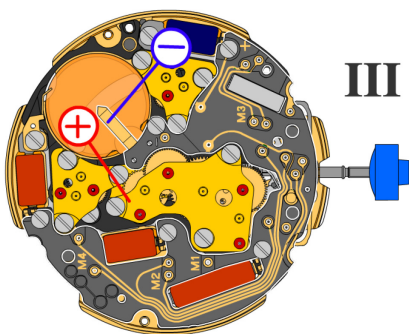

Setting stem in position III, 60 s measuring interval:

Typical consumption	0.10 μA
Maximal consumption	0.30 μA

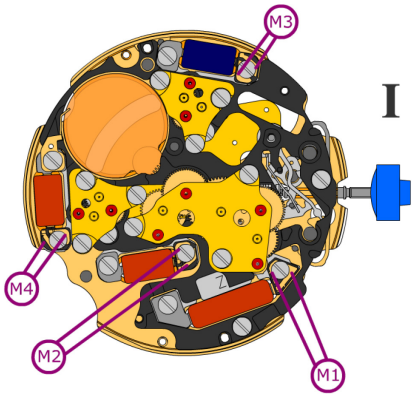

Coil resistance M1 **1.90 kΩ .. 2.10 kΩ**

Coil resistance M2 **1.68 kΩ .. 1.88 kΩ**

Coil resistance M3 **1.68 kΩ .. 1.88 kΩ**

Coil resistance M4 **1.68 kΩ .. 1.88 kΩ**

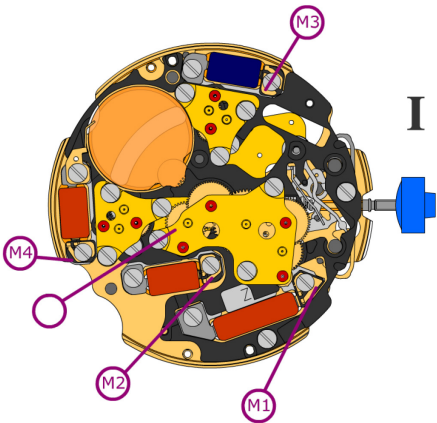

Coil isolation M1/M2/M3/M4 **∞ kΩ**

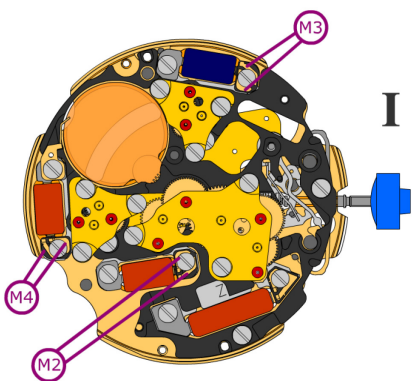

Signal generator (4.9 ms, 8 Hz):

Lower working voltage limit
M2/M3/M4 **1.20 V**