

**Watch Movement Specification and Drawing**

2 Hands Multi-eye Movement

**VD72A**



Movement Size: **10 1/2"**  
 Diameter: **Φ23.70mm**  
 Height: **3.45mm**

Items	Ver.	Items	Ver.
Specification	1		
Appearance	1		
Casing	1		
Hand Fitting	1		
Hand Setting Stem	1		
Dial	1		
Casing Ring	1		
Assembly Plan	1		
Hands	1		

## CAL.VD72A 10½ Ligne Quartz Movement

### Two Hands with 1 Eye Small Date Hand

#### 1. FUNCTION

- Jewel 0 jewel
- Accuracy Less than  $\pm 20$  seconds / month (Normal temperature range)
- Battery life Approx. 3 years
- Regulation hands unbalance
  - Hour hand : Less than  $0.60 \mu\text{N}\cdot\text{m}$  ( 60 mg·mm )
  - Minute hand : Less than  $0.60 \mu\text{N}\cdot\text{m}$  ( 60 mg·mm )
  - Small hand : Less than  $0.05 \mu\text{N}\cdot\text{m}$  ( 5 mg·mm )  
(Date hand)
- Additional function Date display with quick date correction

#### 2. USE AND TEST CONDITION

- Battery SR626SW (Recommended battery is SEIZAIKEN)
- Operation temperature range From  $- 5 \text{ }^{\circ}\text{C}$  to  $+ 50 \text{ }^{\circ}\text{C}$
- Antimagnetic  $\geq 1600 \text{ A / m}$  (Direct current magnetic field)
- Test of accuracy 10 seconds (Duration of measurement)

**\* All specifications are subject to change without notice.**

# Appearance

# VD72A

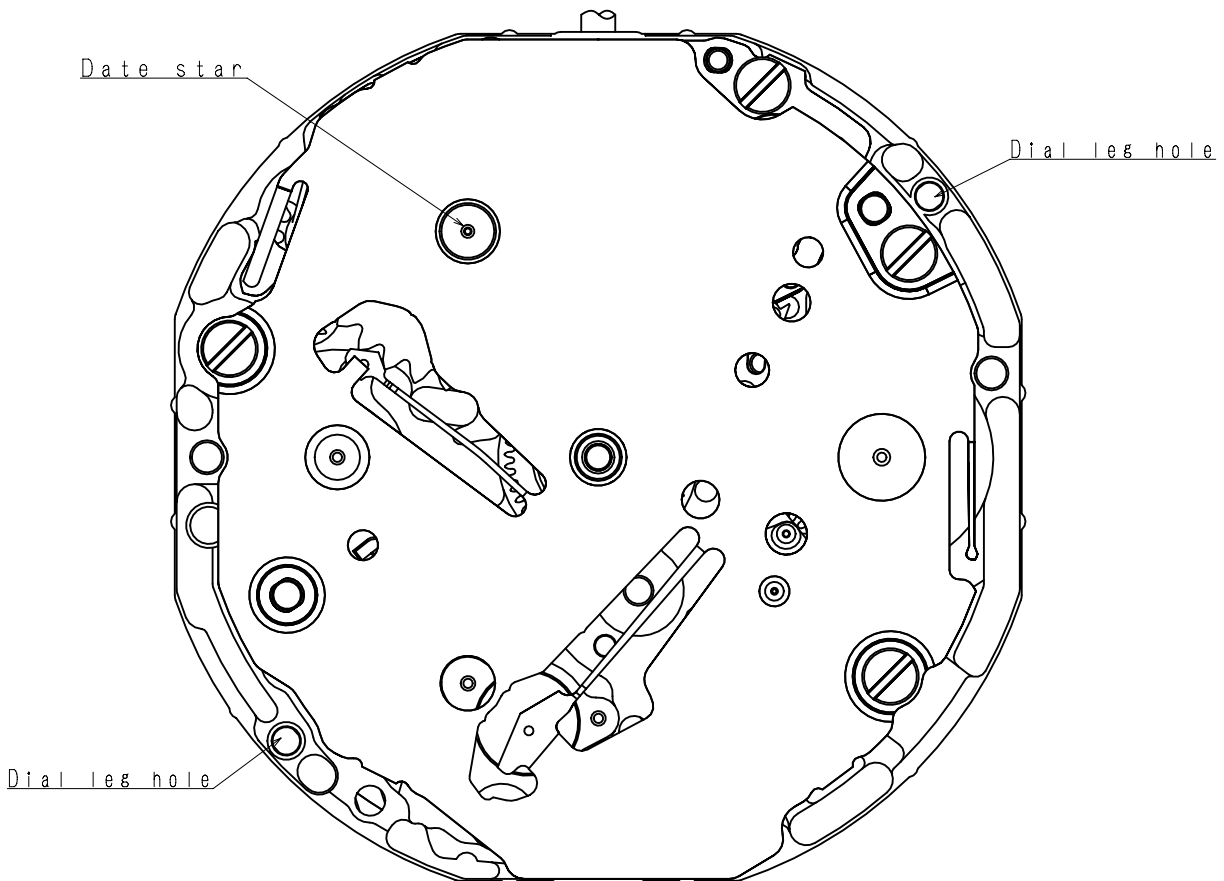
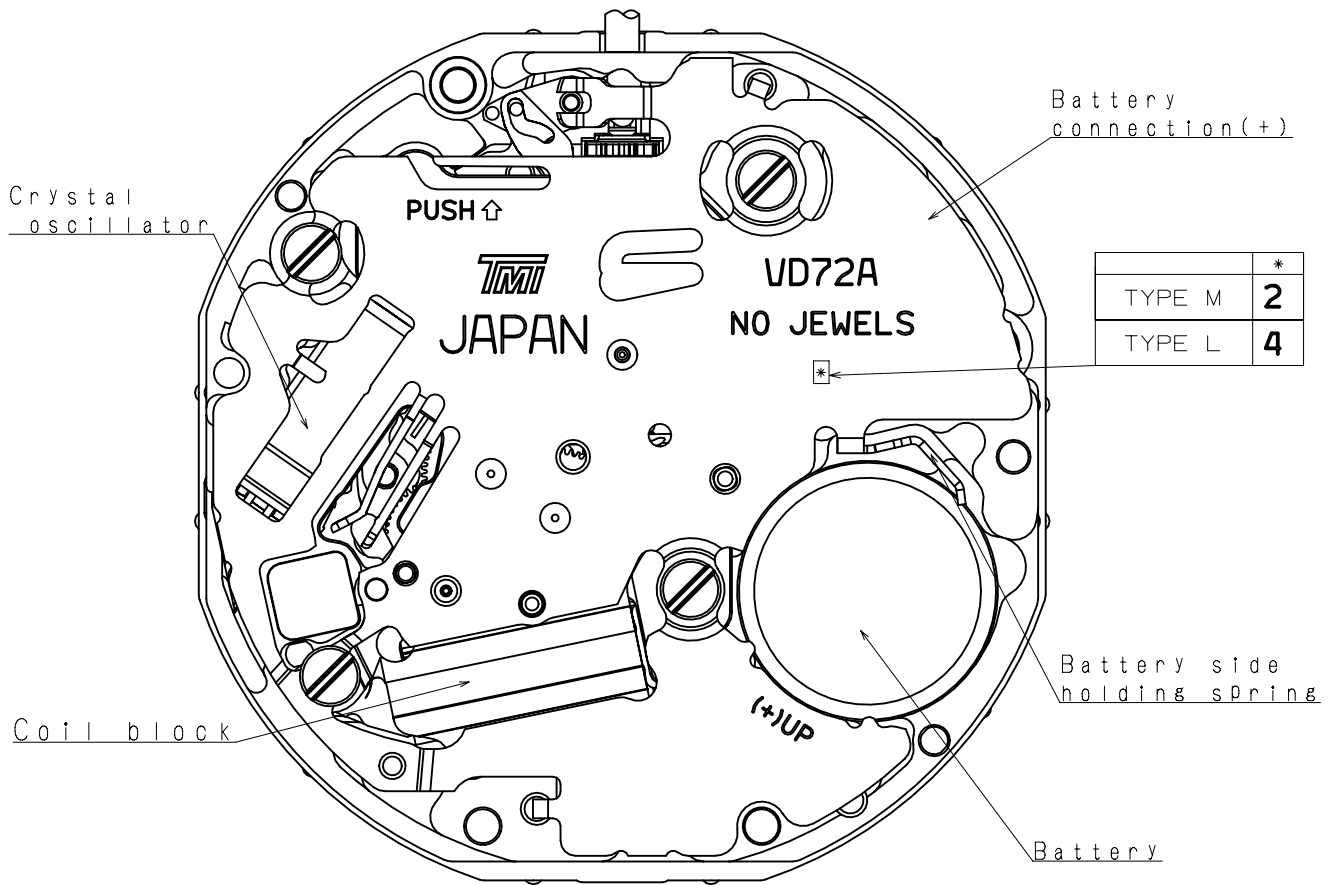

Version : 1

\* First pull out stroke 45  
 \*\* Second pull out stroke 39.9

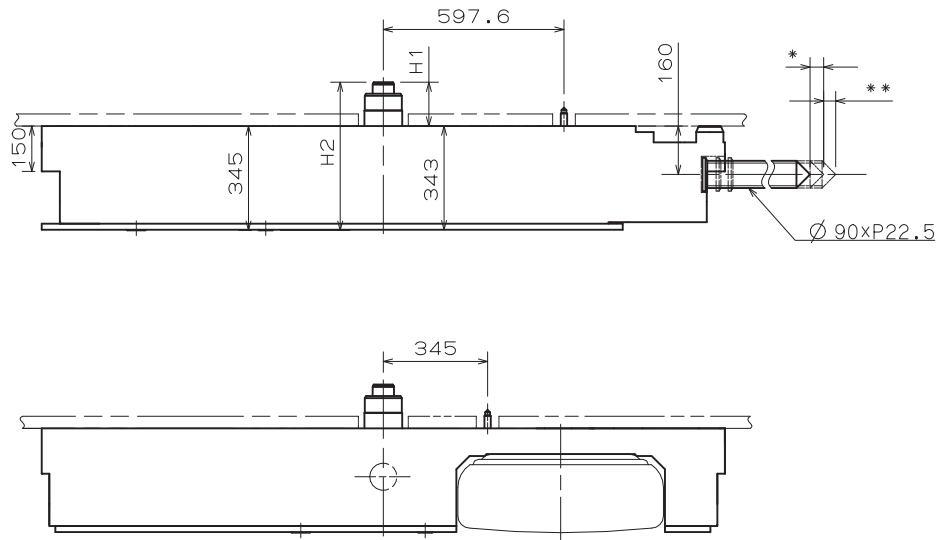

Center post	中心柱位	TYPE M 一般針高	TYPE L 高針
Maximum height from main plate surface 與機芯平面的最大高度	H1	150	230
Total height incl. movement 機芯總高度	H2	495	575

Hand Setting Stem	TYPE A	TYPE B
L1	2436	3012

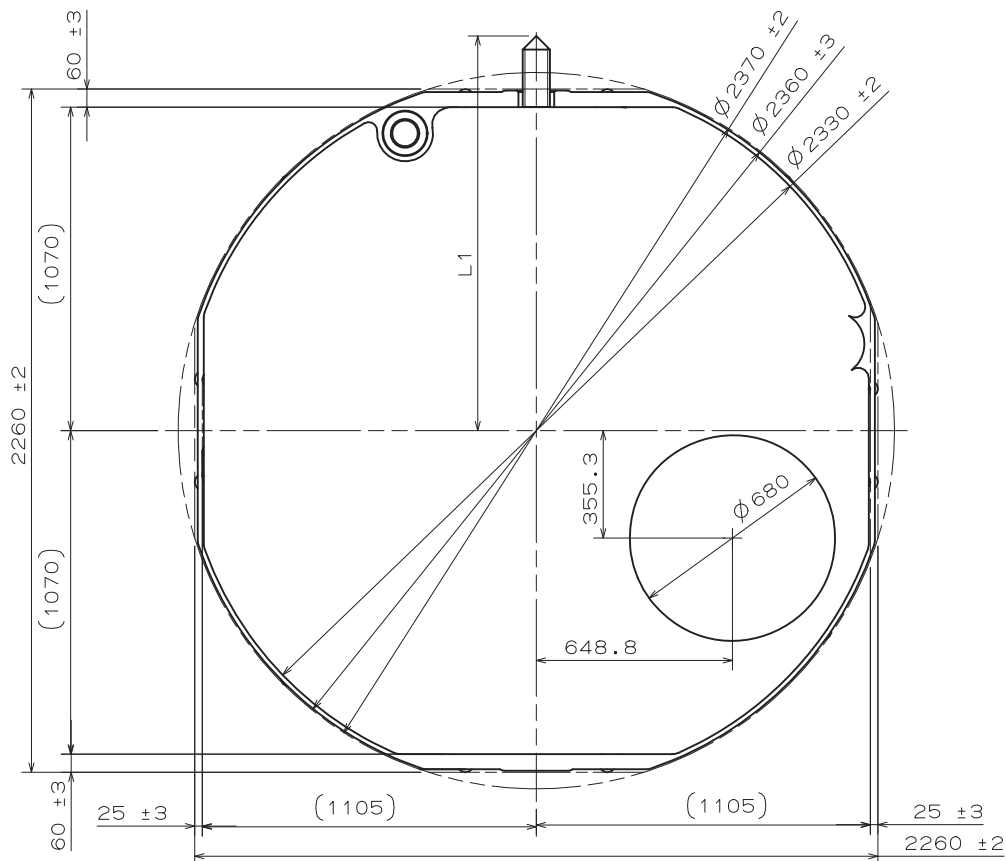

- \* Hour hand unbalance  $\leq 0.6 \mu\text{N}\cdot\text{m}$  (60mg·mm)
- \* Minute hand unbalance  $\leq 0.6 \mu\text{N}\cdot\text{m}$  (60mg·mm)
- \* Date hand unbalance  $\leq 0.05 \mu\text{N}\cdot\text{m}$  (5mg·mm)

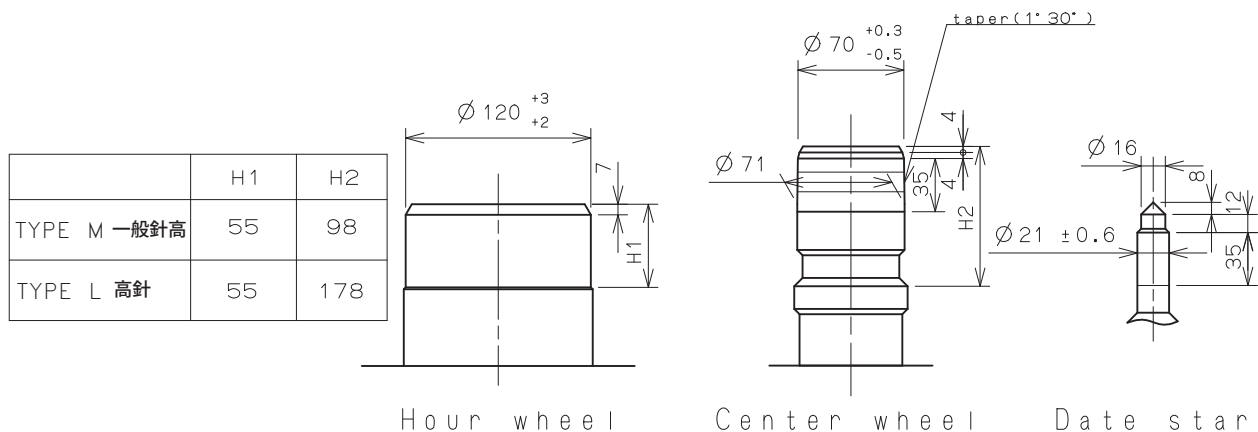

Part name	Part No.	
	TYPE M 一般針高	TYPE L 高針
Hour wheel 時針輪	0273 169	0273 035
Center wheel 分針輪	0221 069	0221 076
Date star 日曆針輪	0970 169	0970 037

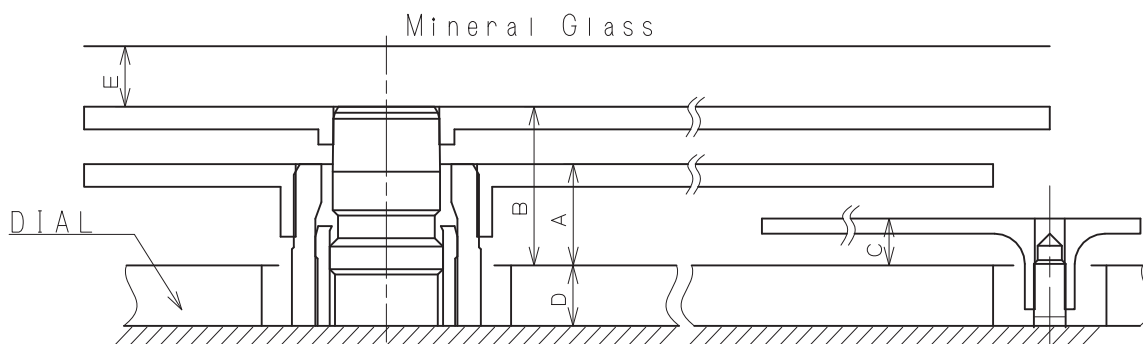

	A	B	C	D	E
TYPE M 一般針高	72	110	31	40	35
TYPE L 高針	95	145	41	85	40

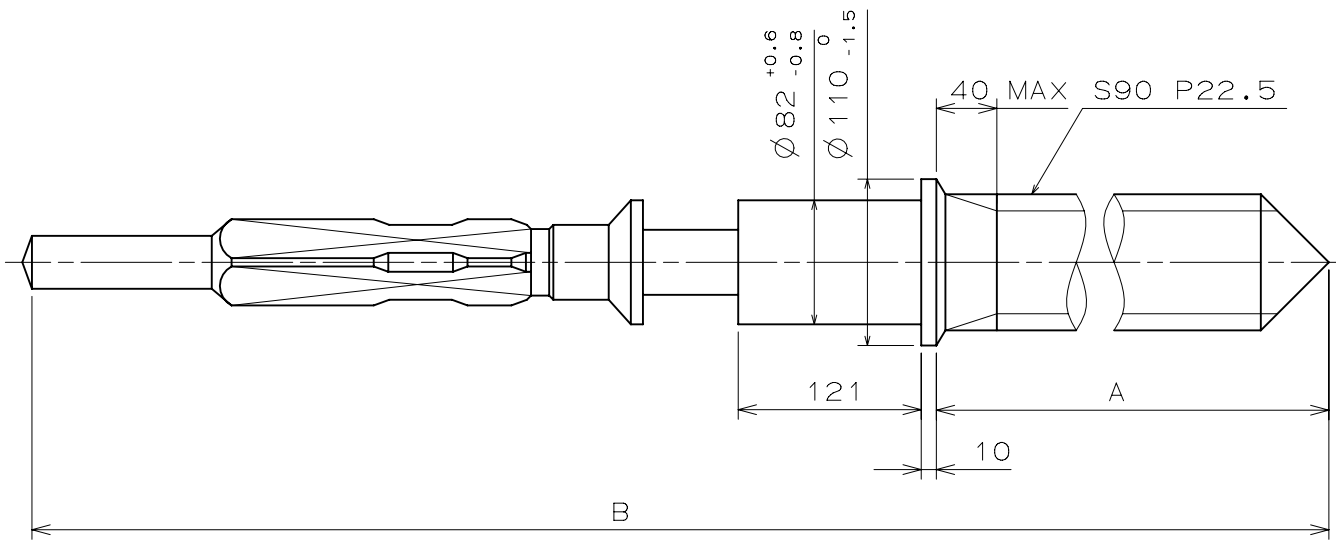

	Part No.	A	B
TYPE A	0351 177	1371	1969
TYPE B	0351 122	1947	2545

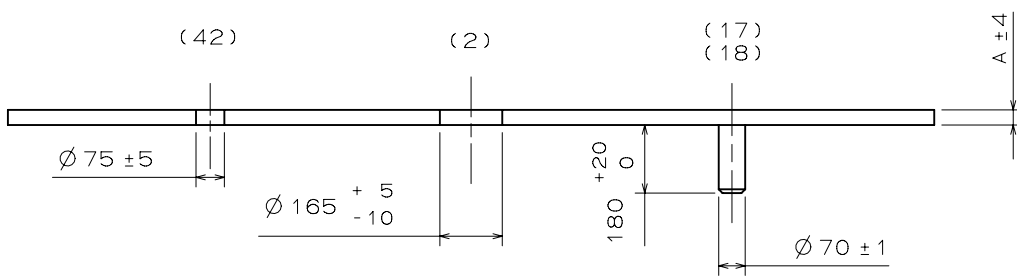
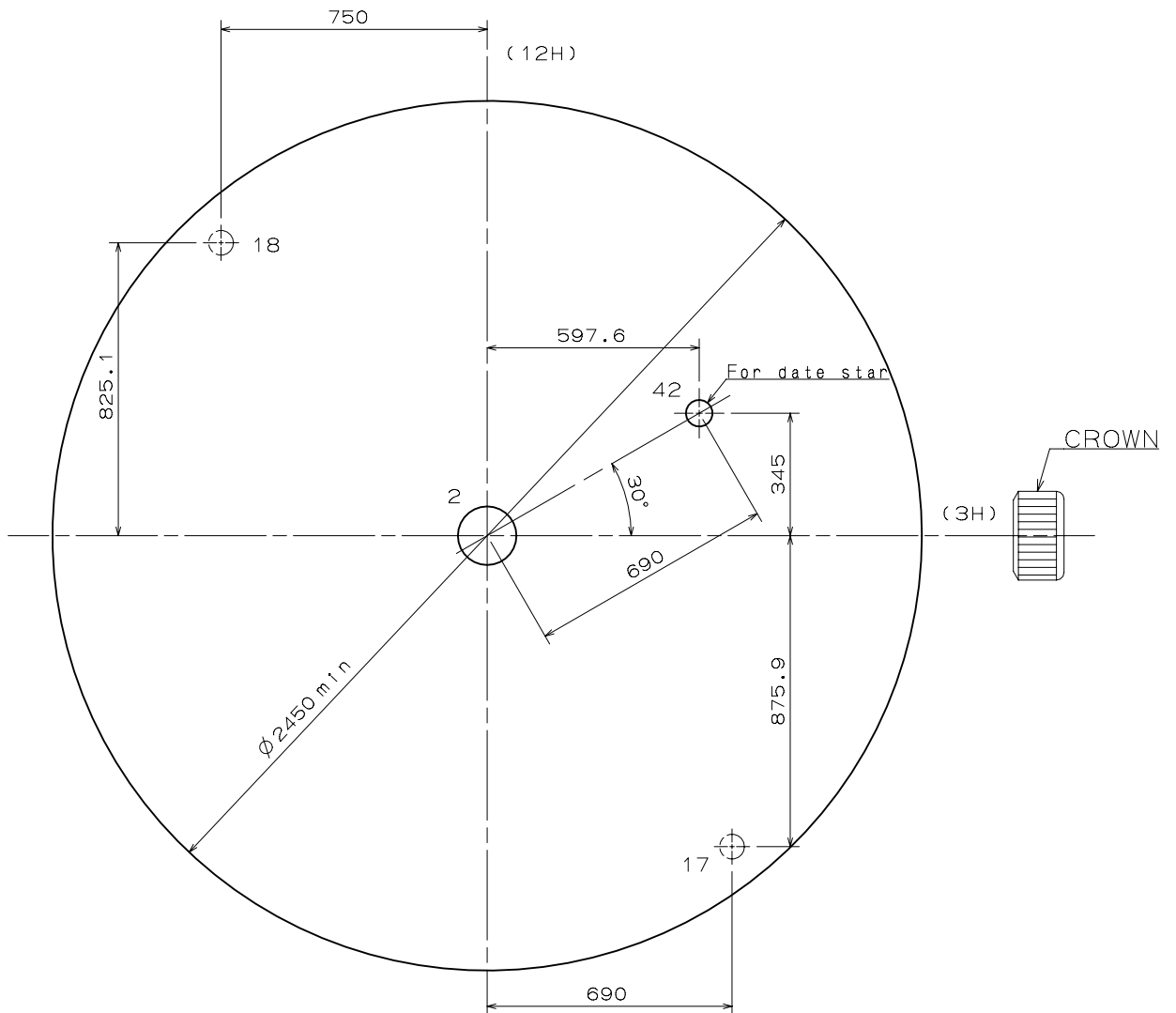

	TYPE M	TYPE L
A	40	85

# Casing Ring

VD72A

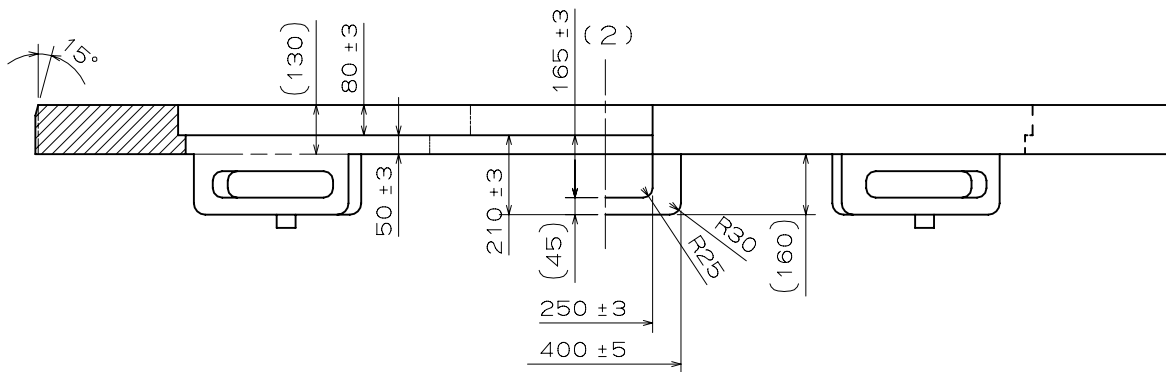
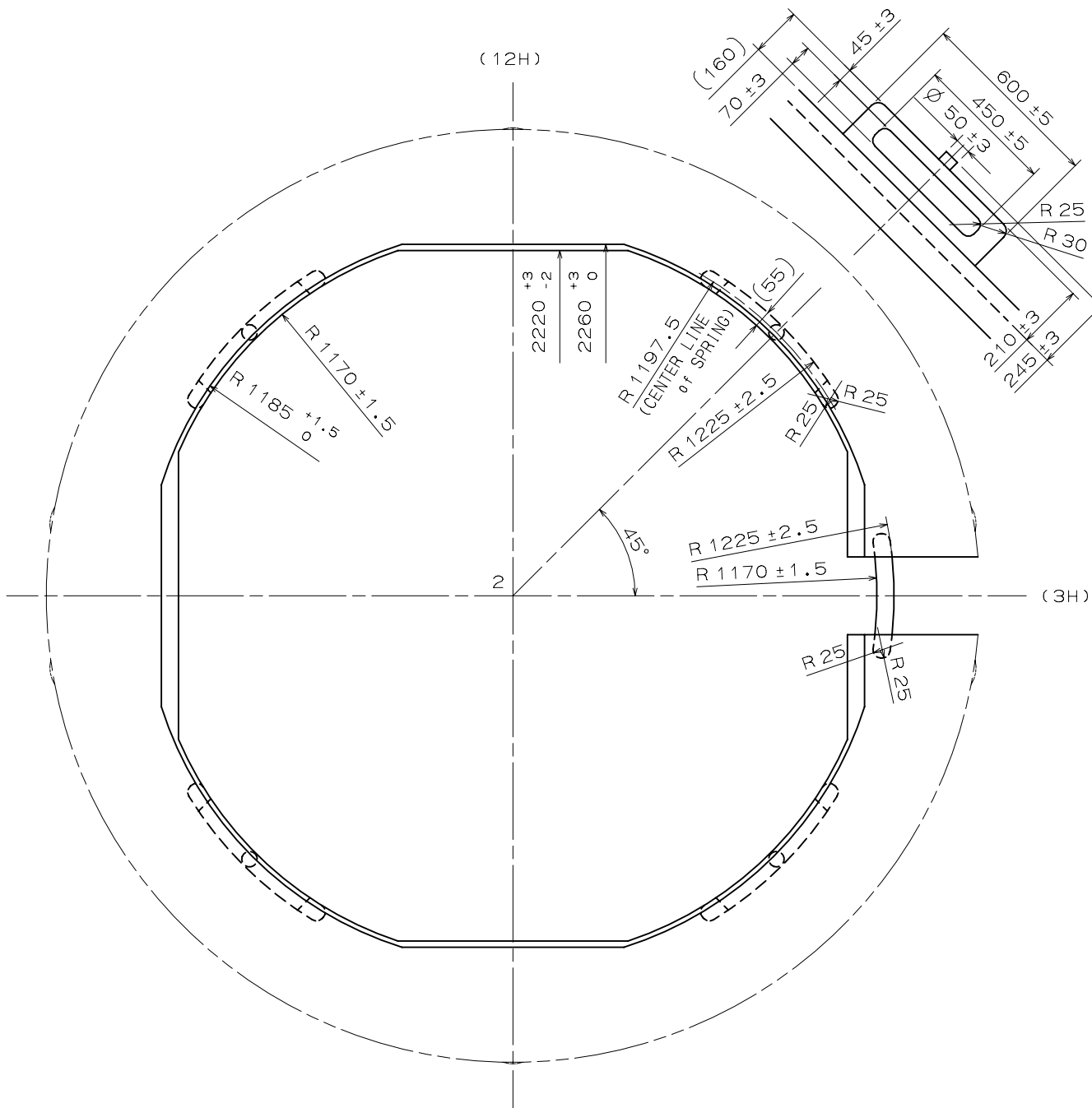

SECTIONAL VIEW of 12H DIRECTION

SIDE VIEW from 3H DIRECTION

Unit : 1=1/100mm

Version : 1



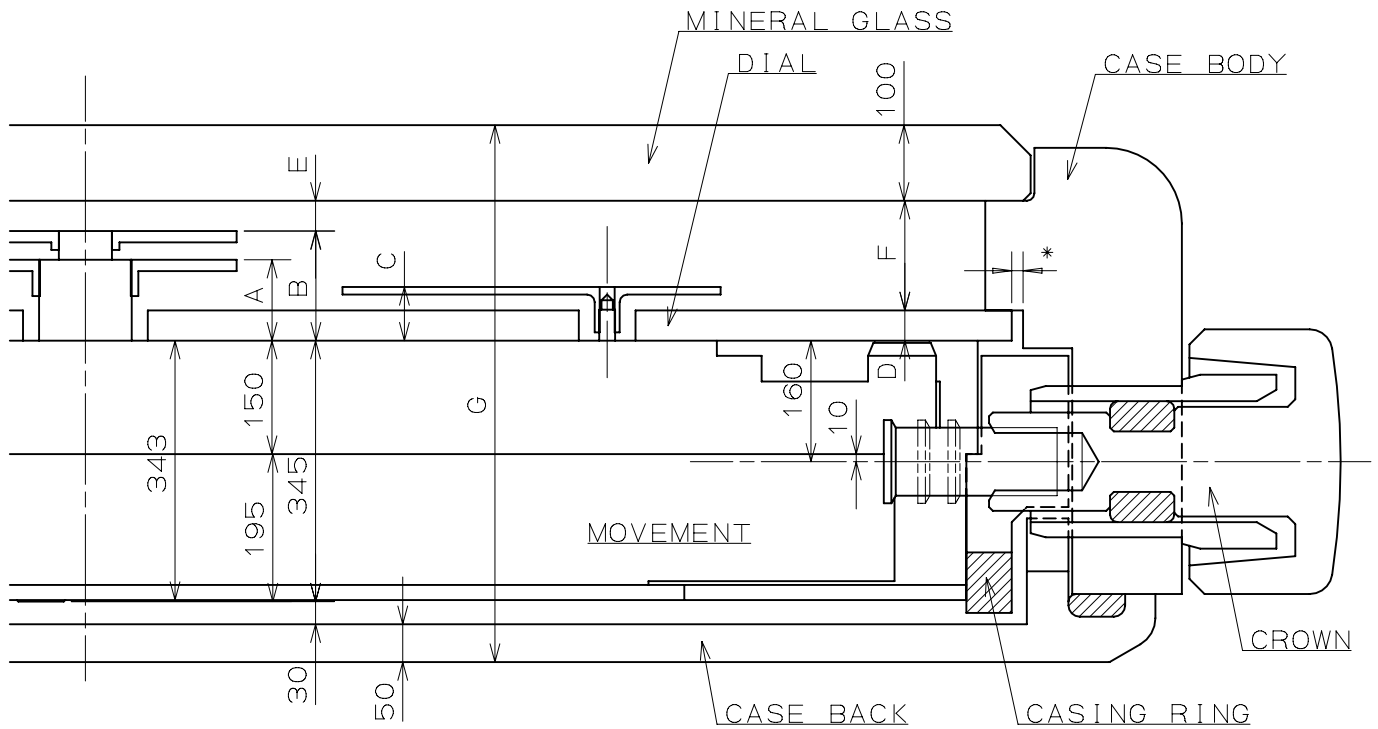

	A	B	C	D	E	F	G
TYPE M	112	150	71	40	35	145	710
TYPE L	180	230	126	85	40	185	795

\*Recommended Dimension(Clearance of DIAL and CASE BODY):15

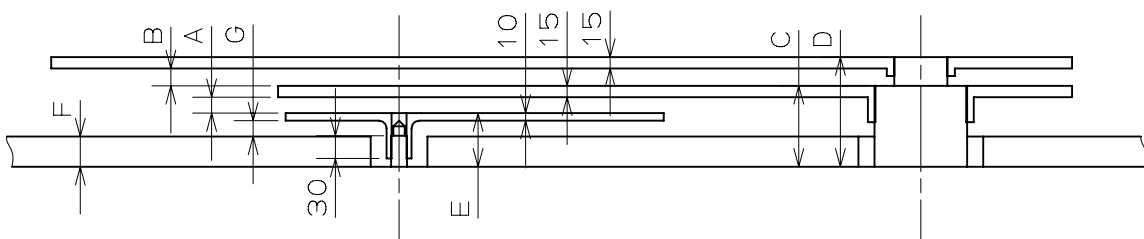

	A	B	C	D	E	F	G
TYPE M	26	23	112	150	71	40	21
TYPE L	39	35	180	230	126	85	31

TYPE M

MINUTE

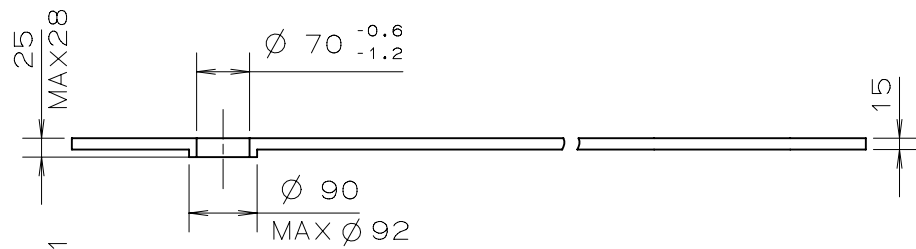

HOUR

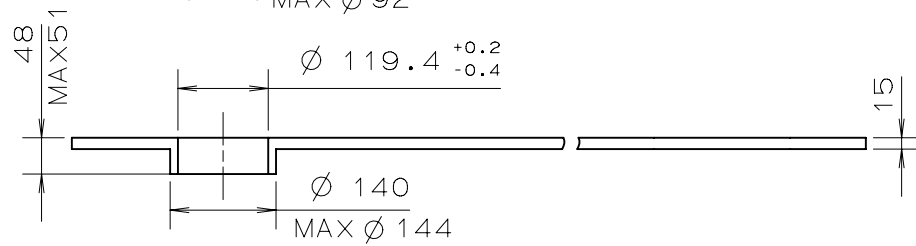

DATE

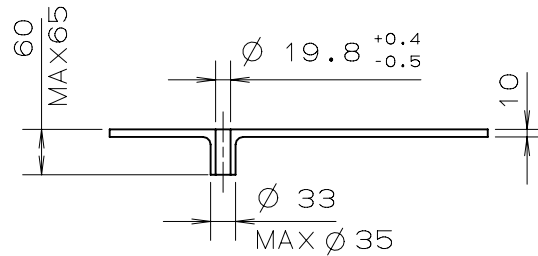

TYPE L

MINUTE

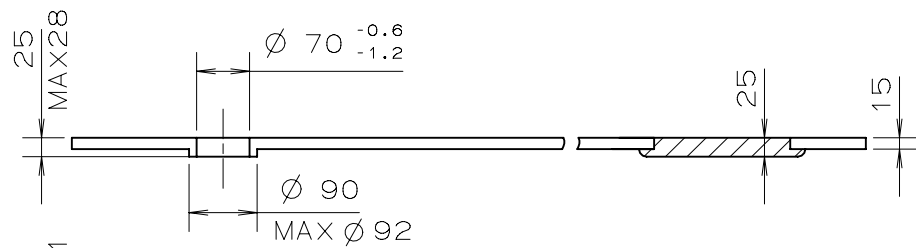

HOUR

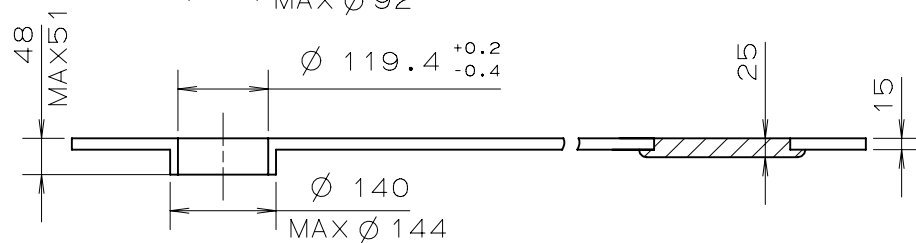

DATE

