

Watch Movement Specification and Drawing

2 Hands Multi-eye Movement

VD86A



Movement Size: **10 1/2"**
 Diameter: **Φ23.70mm**
 Height: **3.45mm**

Items	Ver.	Items	Ver.
Specification	1		
Appearance	1		
Casing	1		
Hand Fitting	1		
Hand Setting Stem	1		
Dial	1		
Casing Ring	1		
Assembly Plan	1		
Hands	1		

CAL.VD86A 10½ Ligne Quartz Movement

Two Hands with 3 Eyes Small Second, Date & Retrograde Day Hands

1. FUNCTION

- Jewel 0 jewel
- Accuracy Less than ± 20 seconds / month (Normal temperature range)
- Battery life Approx. 3 years
- Regulation hands unbalance
 - Hour hand : Less than $0.60 \mu\text{N}\cdot\text{m}$ (60 mg·mm)
 - Minute hand : Less than $0.60 \mu\text{N}\cdot\text{m}$ (60 mg·mm)
 - Small hands : Less than $0.05 \mu\text{N}\cdot\text{m}$ (5 mg·mm)(Second, date & retrograde day hands)

- Additional function Date & Retrograde Day display with quick date correction

2. USE AND TEST CONDITION

- Battery SR626SW (Recommended battery is SEIZAIKEN)
- Operation temperature range From $- 5 \text{ }^{\circ}\text{C}$ to $+ 50 \text{ }^{\circ}\text{C}$
- Antimagnetic $\geq 1600 \text{ A / m}$ (Direct current magnetic field)
- Test of accuracy 10 seconds (Duration of measurement)

*** All specifications are subject to change without notice.**

Appearance

VD86A

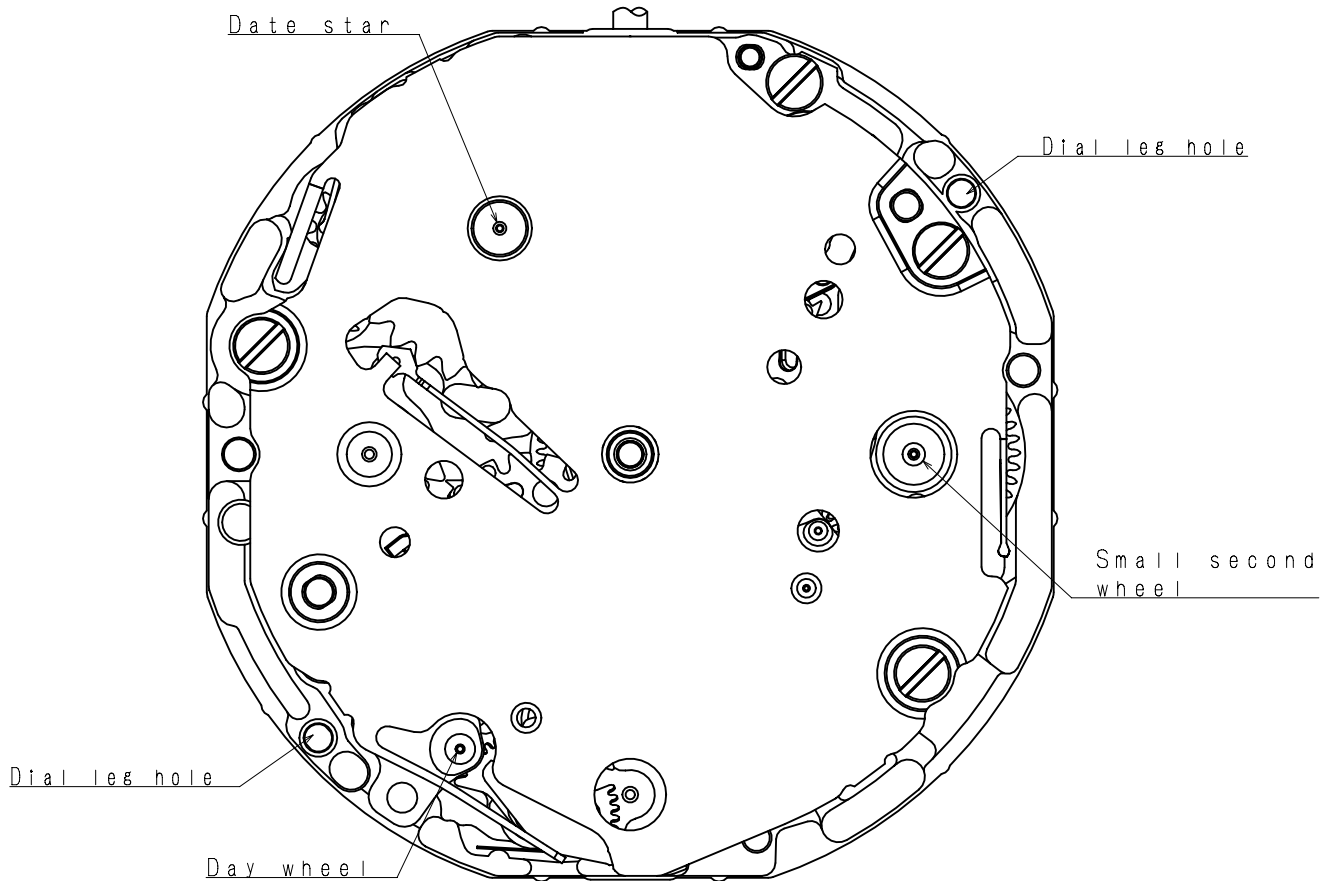
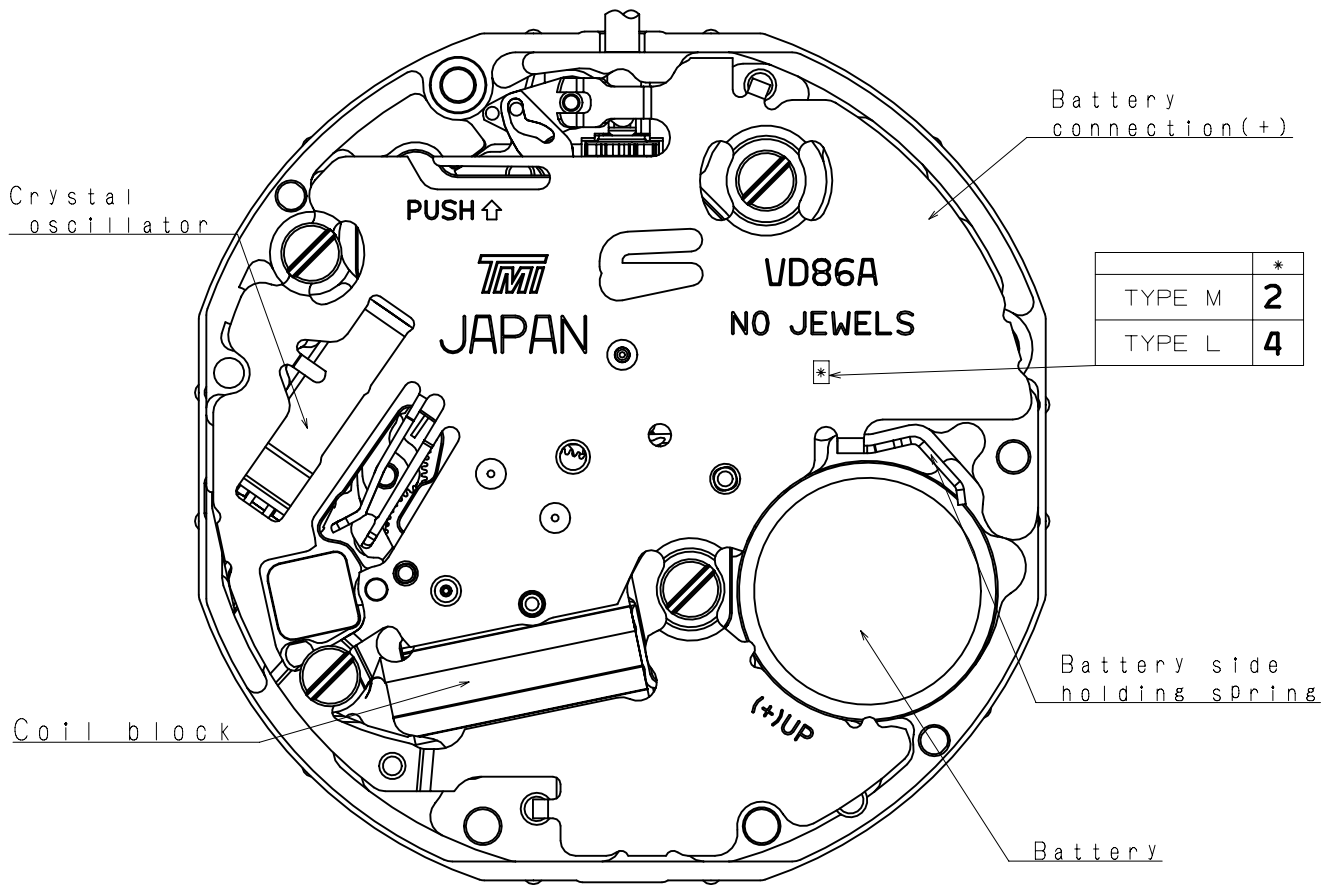

Version : 1

* First pull out stroke 45
 ** Second pull out stroke 39.9

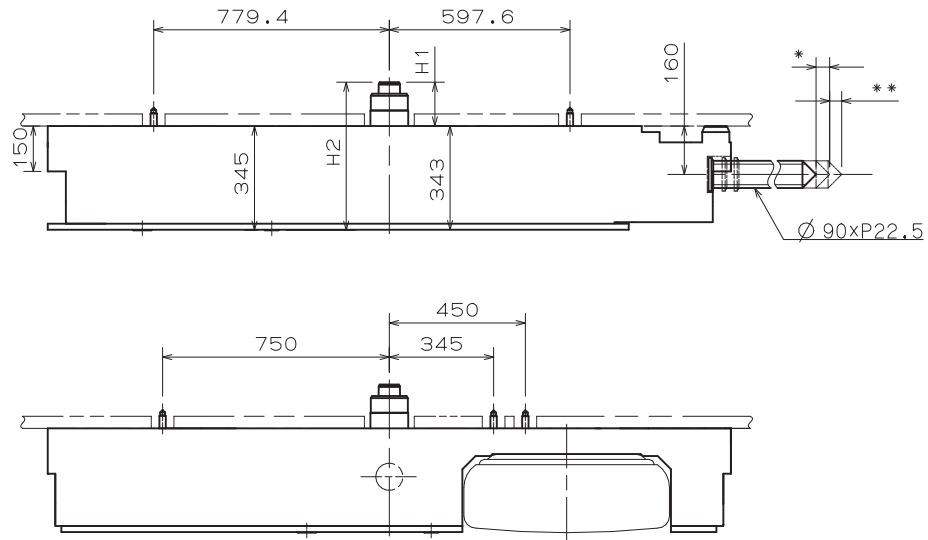

Center post 中心柱位	TYPE M 一般針高	TYPE L 高針	Hand Setting Stem	
			TYPE A	TYPE B
Maximum height from main plate surface 與機芯平面的最大高度	H1	150	2436	3012
Total height incl. movement 機芯總高度	H2	495		

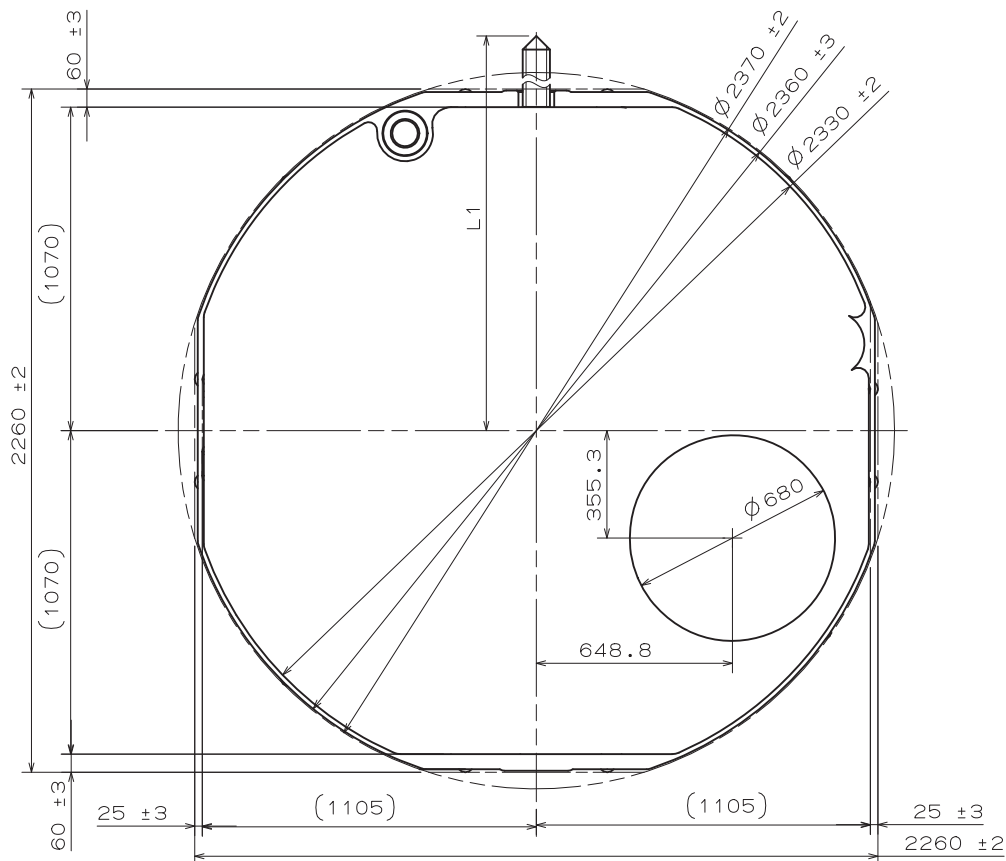

- * Hour hand unbalance $\leq 0.6 \mu\text{N} \cdot \text{m} (60\text{mg} \cdot \text{mm})$
- * Minute hand unbalance $\leq 0.6 \mu\text{N} \cdot \text{m} (60\text{mg} \cdot \text{mm})$
- * Small second hand unbalance $\leq 0.05 \mu\text{N} \cdot \text{m} (5\text{mg} \cdot \text{mm})$
- * Day hand unbalance $\leq 0.05 \mu\text{N} \cdot \text{m} (5\text{mg} \cdot \text{mm})$
- * Date hand unbalance $\leq 0.05 \mu\text{N} \cdot \text{m} (5\text{mg} \cdot \text{mm})$

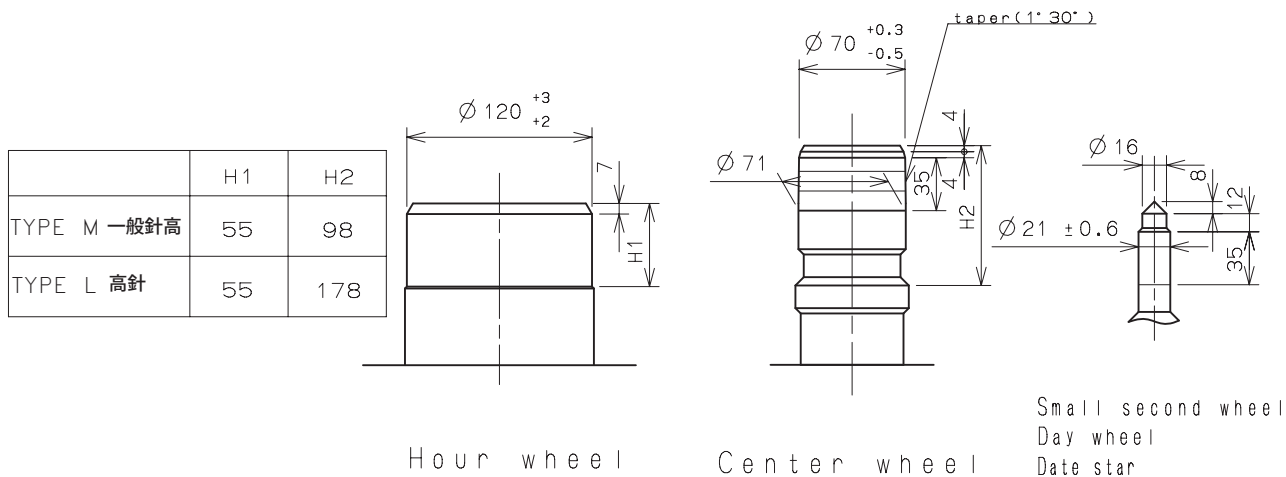

Part name	Part No.	
	TYPE M 一般針高	TYPE L 高針
Hour wheel 時針輪	0273 169	0273 035
Center wheel 分針輪	0221 069	0221 076
Small second wheel 小秒針輪	0240 169	0240 015
Day wheel 星期針輪	1019 170	1019 041
Date star 日曆針輪	0970 169	0970 037

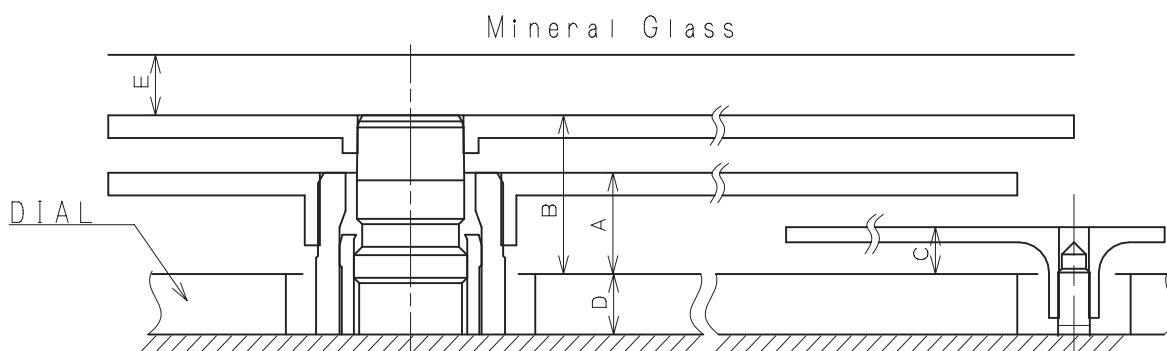

	A	B	C	D	E
TYPE M 一般針高	72	110	31	40	35
TYPE L 高針	95	145	41	85	40

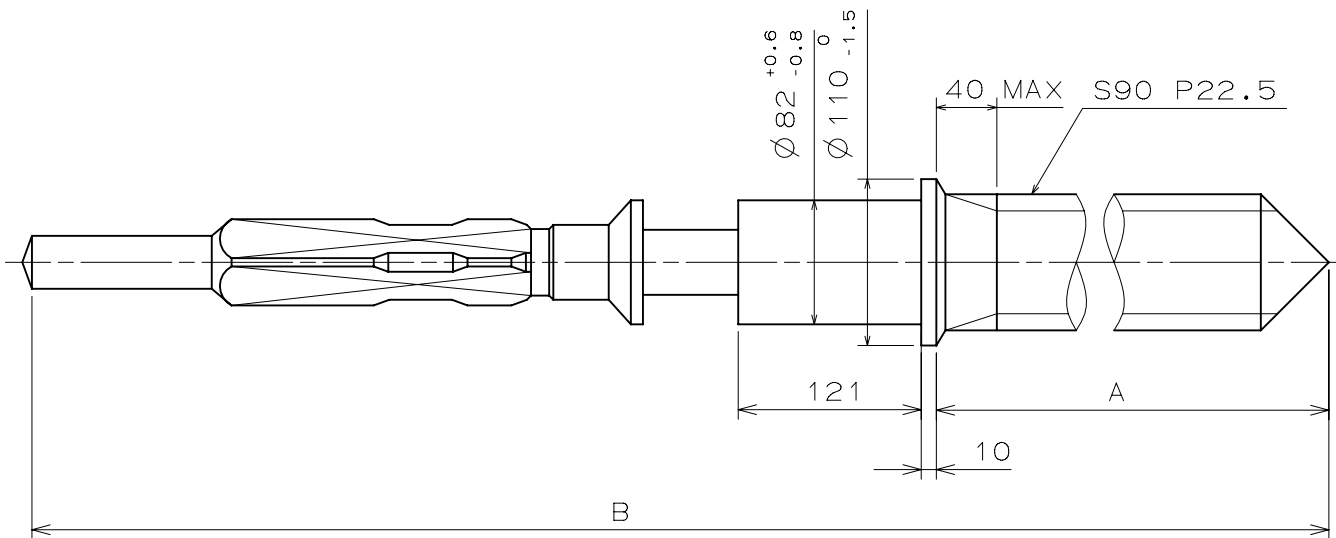

	Part No.	A	B
TYPE A	0351 177	1371	1969
TYPE B	0351 122	1947	2545

Operating area of DAY HAND
 Total: 108°
 1 step: 18°

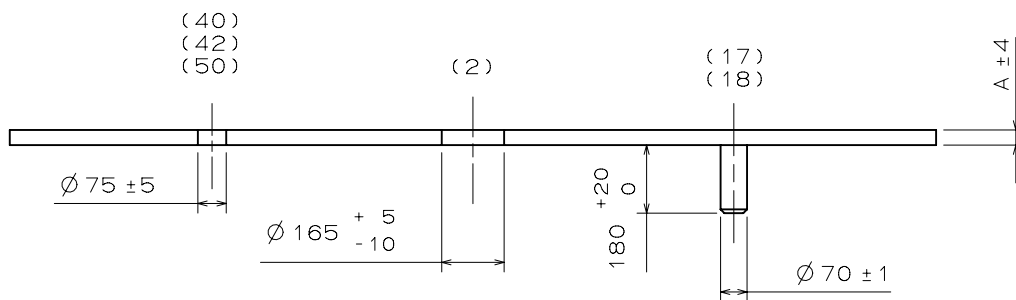
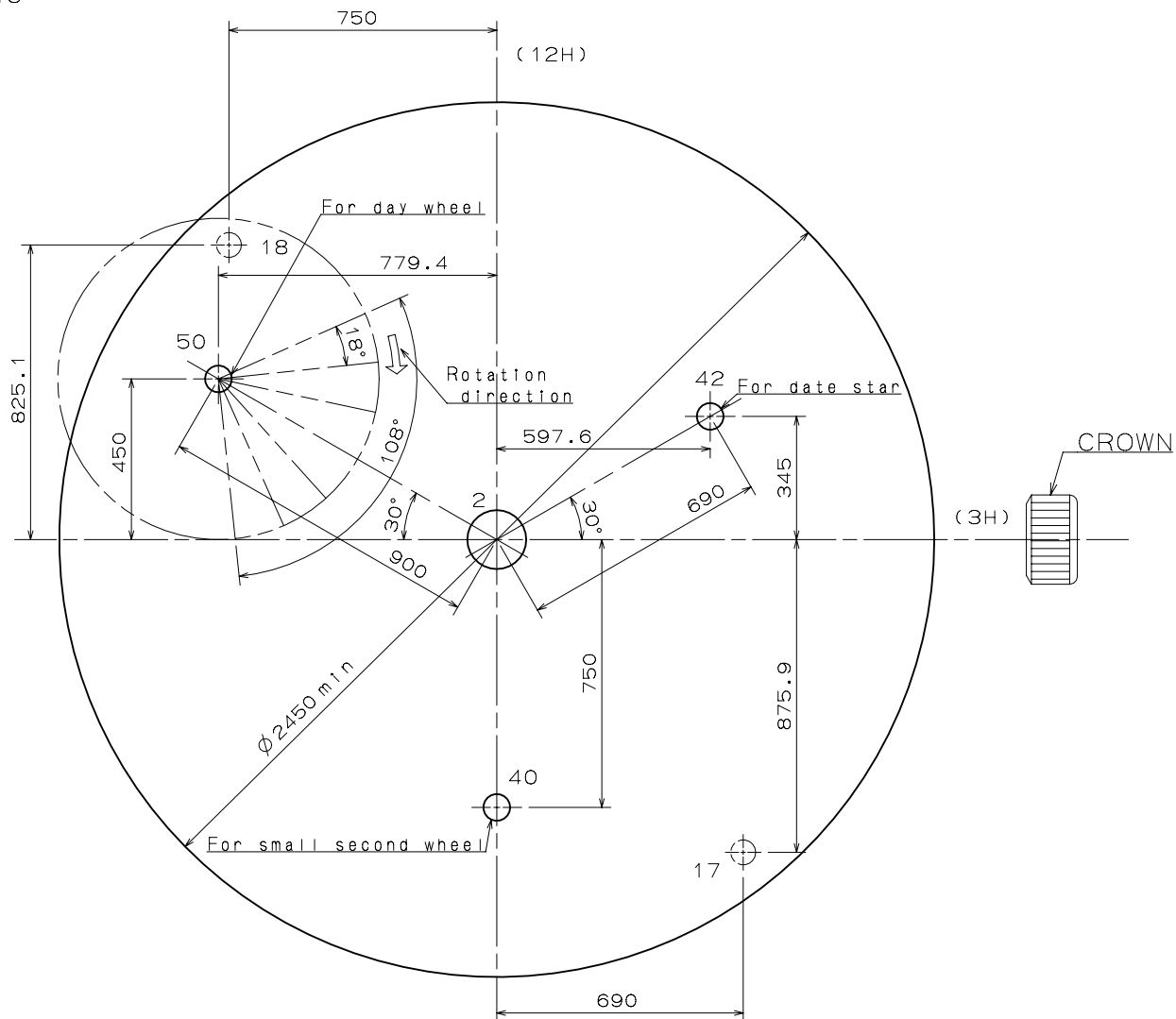

	TYPE M	TYPE L
A	40	85

Casing Ring

VD86A

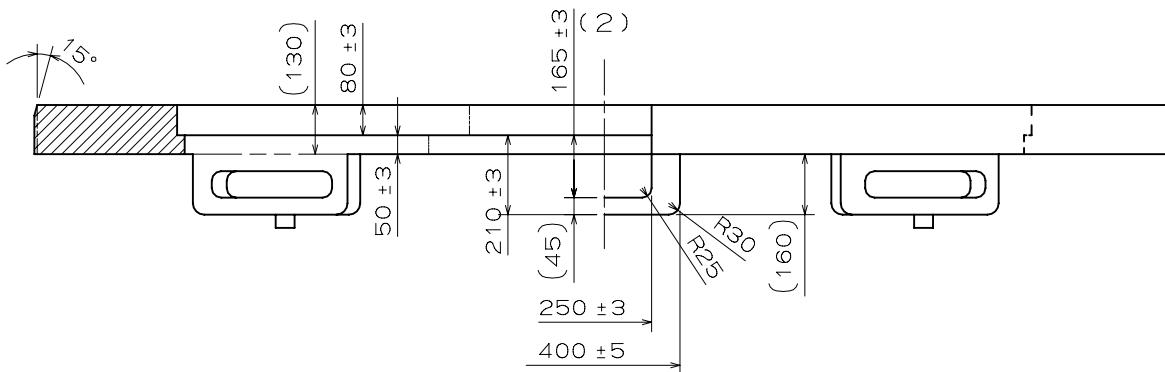
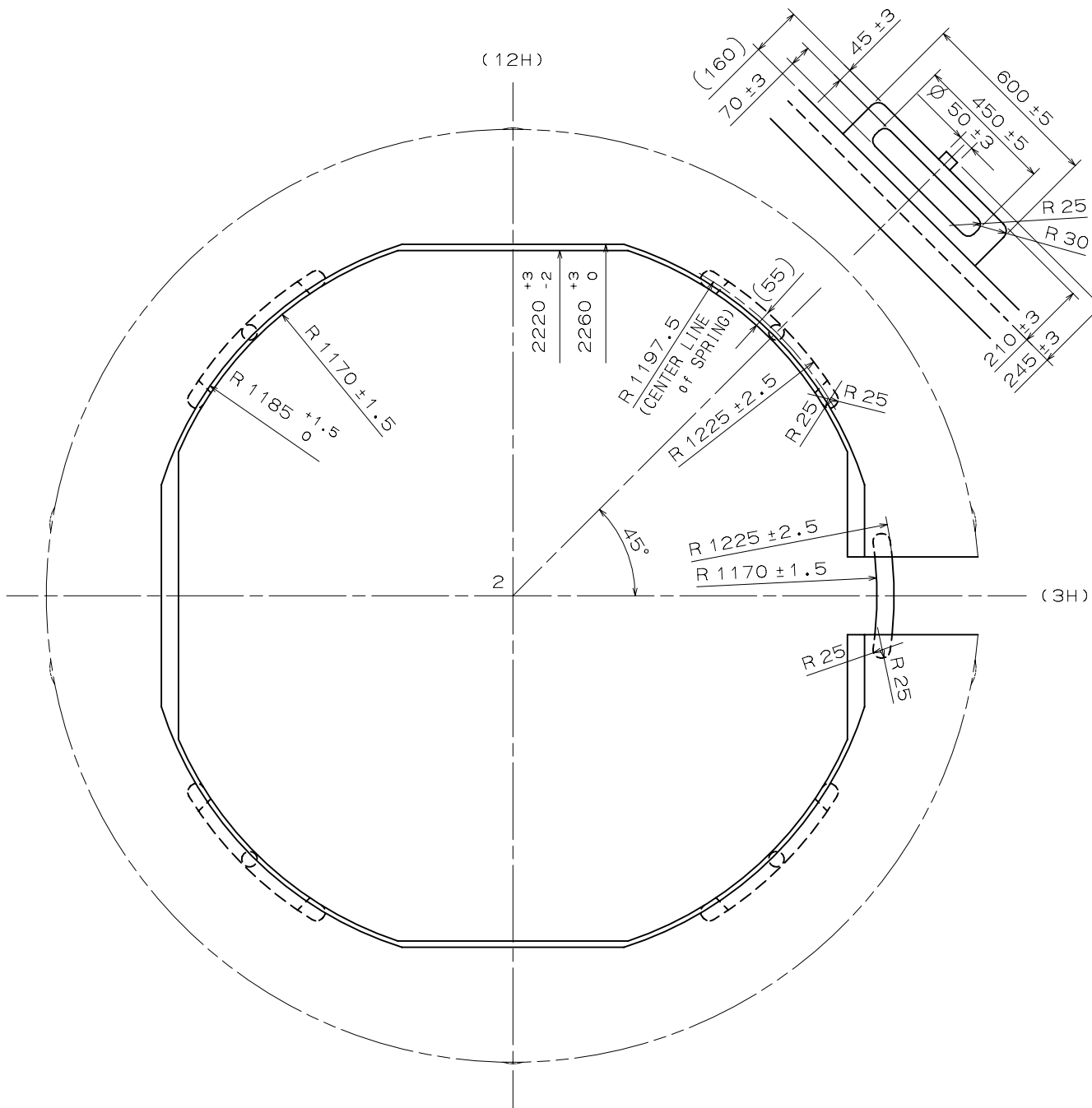

SECTIONAL VIEW of 12H DIRECTION

SIDE VIEW from 3H DIRECTION

Unit : 1=1/100mm

Version : 1

Assembly Plan

VD86A

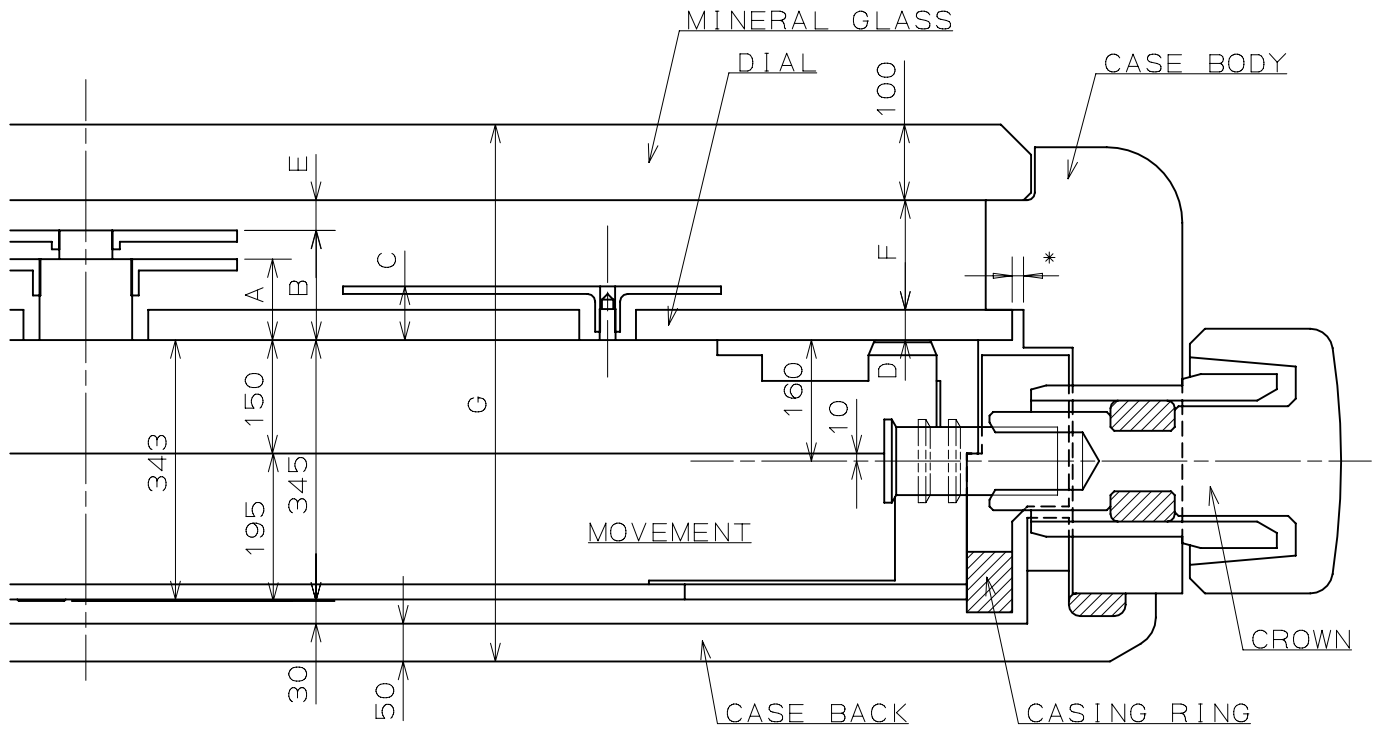

	A	B	C	D	E	F	G
TYPE M	112	150	71	40	35	145	710
TYPE L	180	230	126	85	40	185	795

*Recommended Dimension(Clearance of DIAL and CASE BODY):15

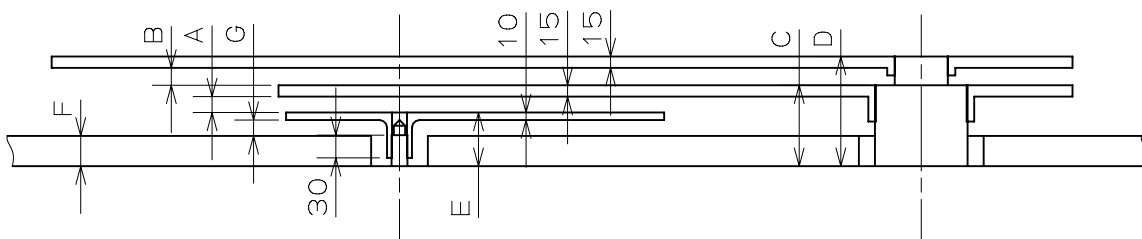

	A	B	C	D	E	F	G
TYPE M	26	23	112	150	71	40	21
TYPE L	39	35	180	230	126	85	31

Unit : 1=1/100mm

Version : 1

TYPE M

MINUTE

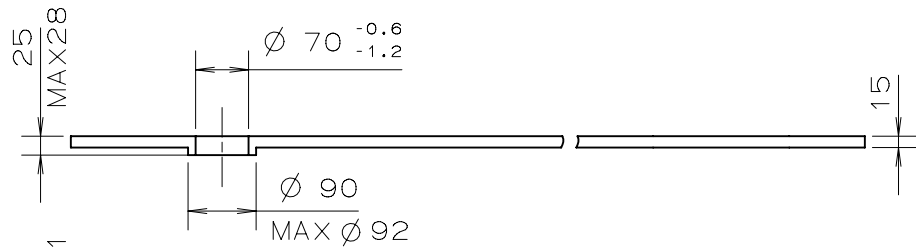

HOUR

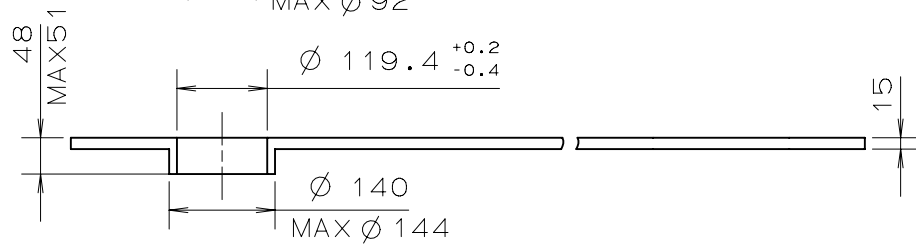

SMALL SECOND
DAY
DATE

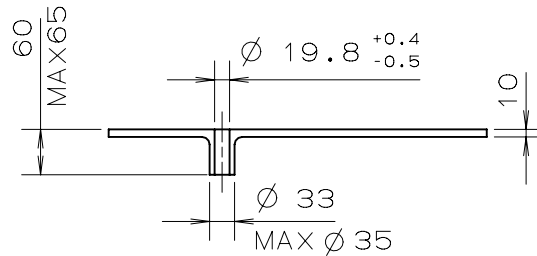

TYPE L

MINUTE

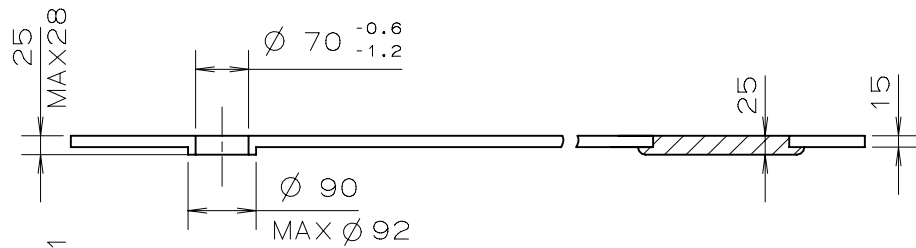

HOUR

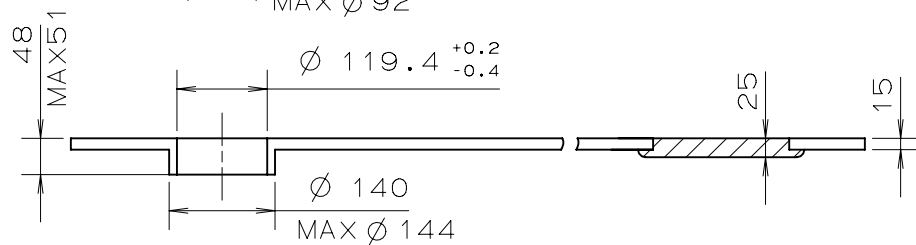

SMALL SECOND
DAY
DATE

