

Watch Movement Specification and Drawing

Sweep Second 3 Hands

VH31A

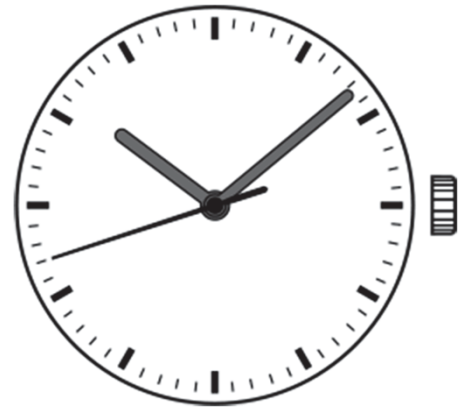

Movement Size: **10 1/2"**
 Diameter: **Φ23.70mm**
 Height: **3.45mm**

Items	Ver.	Items	Ver.
Specification	1		
Appearance	1		
Casing	1		
Hand Fitting	1		
Hand Setting Stem	1		
Dial	1		
Casing Ring	1		
Assembly Plan	1		
Hands	1		

CAL.VH31A 10½ Ligne Quartz Movement

Three Hands (1/4 Center Second Hand)

1. FUNCTION

· Jewel	2 jewels
· Accuracy	Less than ±15 seconds / month (Normal temperature range)
· Battery life	Approx. 2 years
· Regulation hands unbalance	Hour hand : Less than 0.50 μN·m (50 mg·mm) Minute hand : Less than 0.80 μN·m (80 mg·mm) Second hand : Less than 0.30 μN·m (30 mg·mm)

2. USE AND TEST CONDITION

· Battery	SR920SW	(Recommended battery is SEIZAIKEN)
· Operation temperature range	From - 5 °C to + 50 °C	
· Antimagnetic	≥ 1600 A / m	(Direct current magnetic field)
· Test of accuracy	10 seconds	(Duration of measurement)

*** All specifications are subject to change without notice.**

Appearance

VH31A

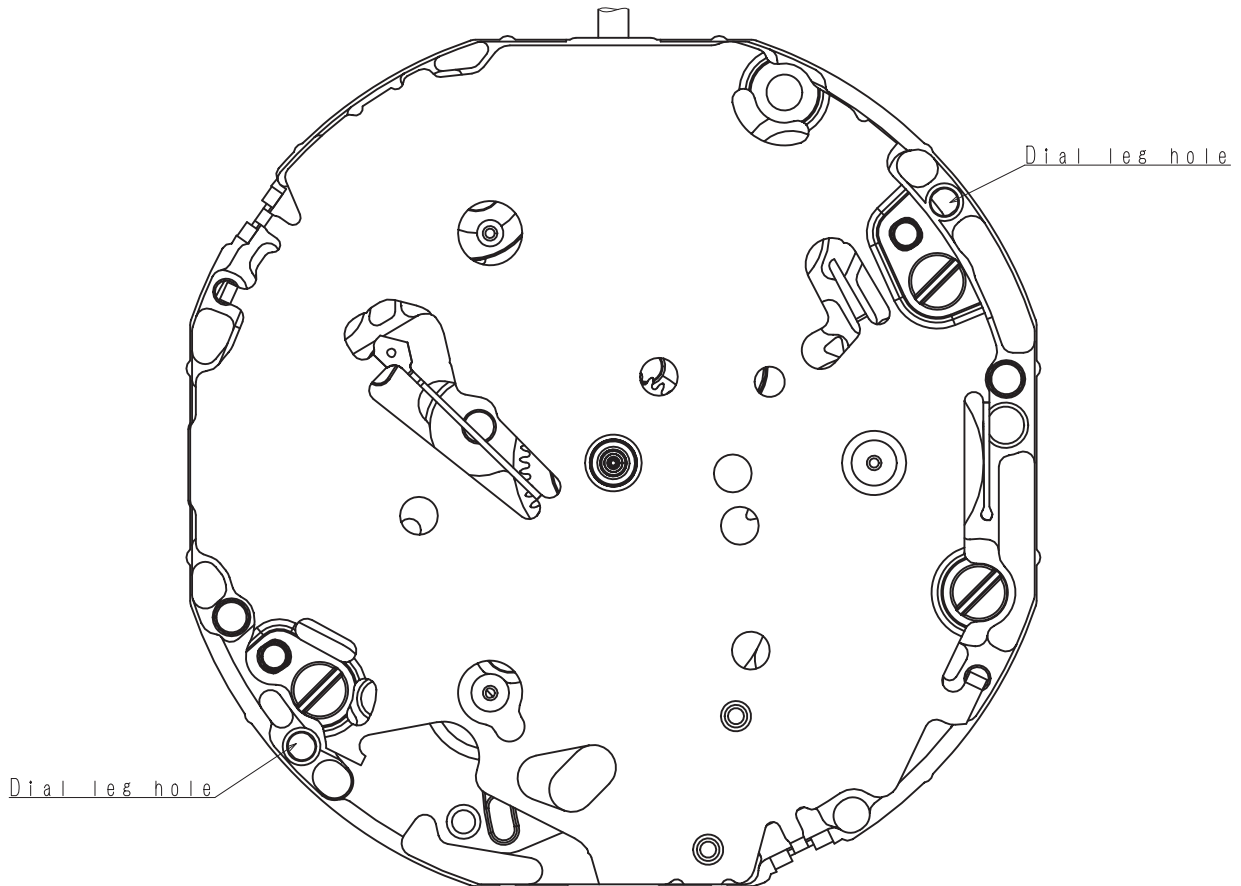
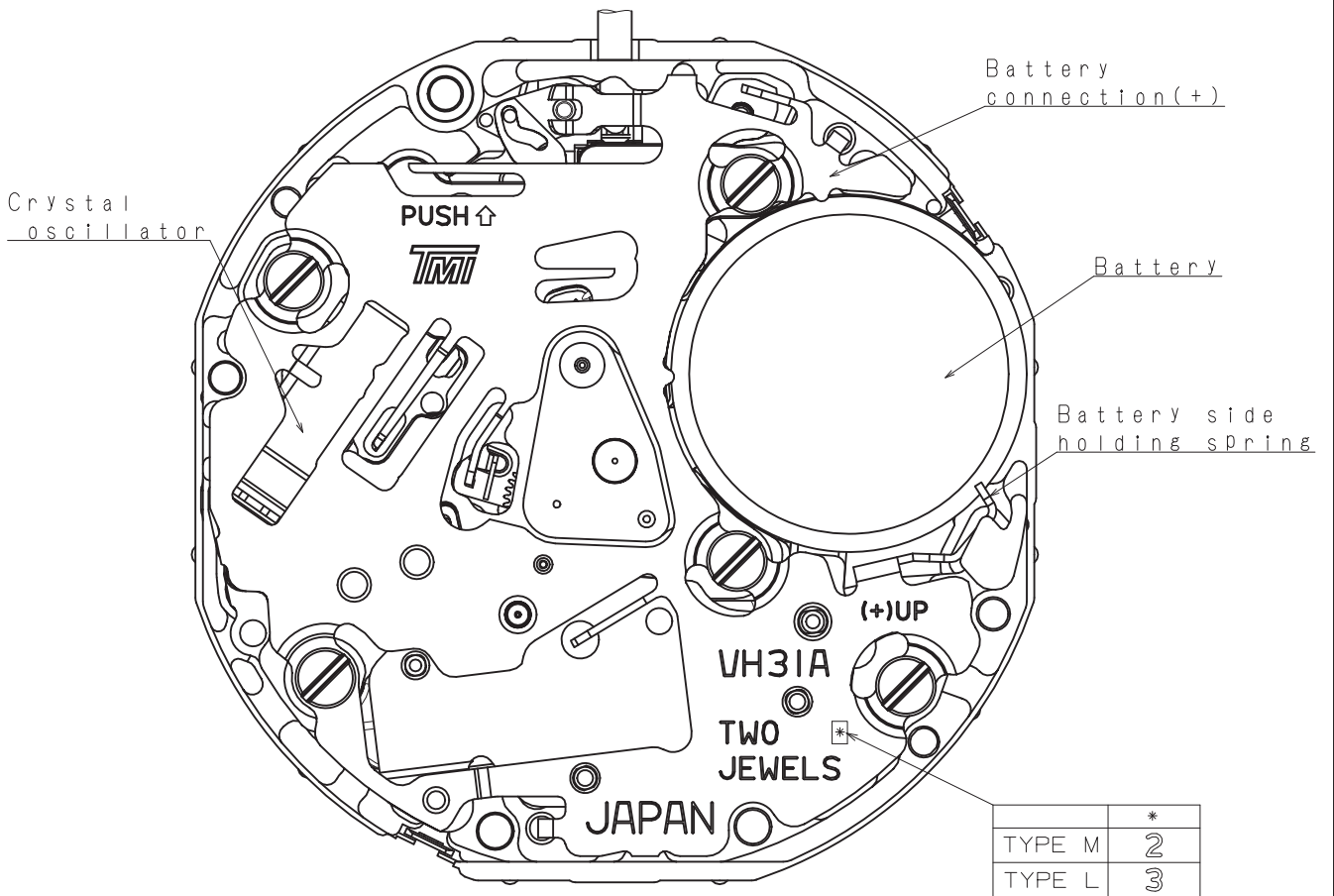

Version : 1

- *Hour hand unbalance $\leq 0.5 \mu\text{N}\cdot\text{m}$ (50mg·mm)
- *Minute hand unbalance $\leq 0.8 \mu\text{N}\cdot\text{m}$ (80mg·mm)
- *Second hand unbalance $\leq 0.3 \mu\text{N}\cdot\text{m}$ (30mg·mm)

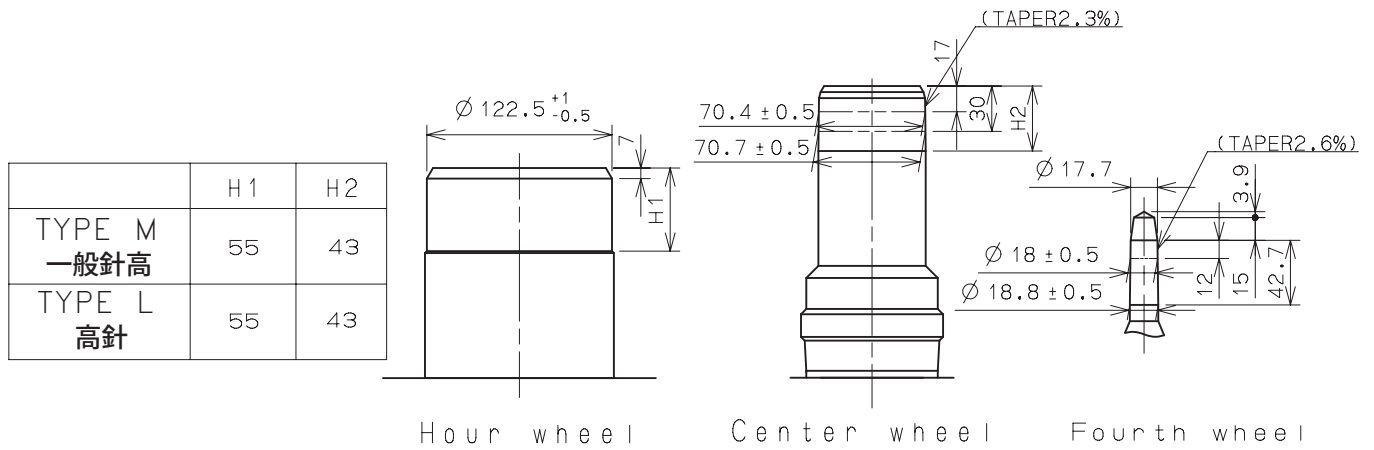

Part name		Part No.	
		TYPE M 一般針高	TYPE L 高針
Hour wheel	時針輪	0273 046	0273 043
Center wheel	分針輪	0221 095	0221 089
Fourth wheel	秒針輪	0144 006	0144 004

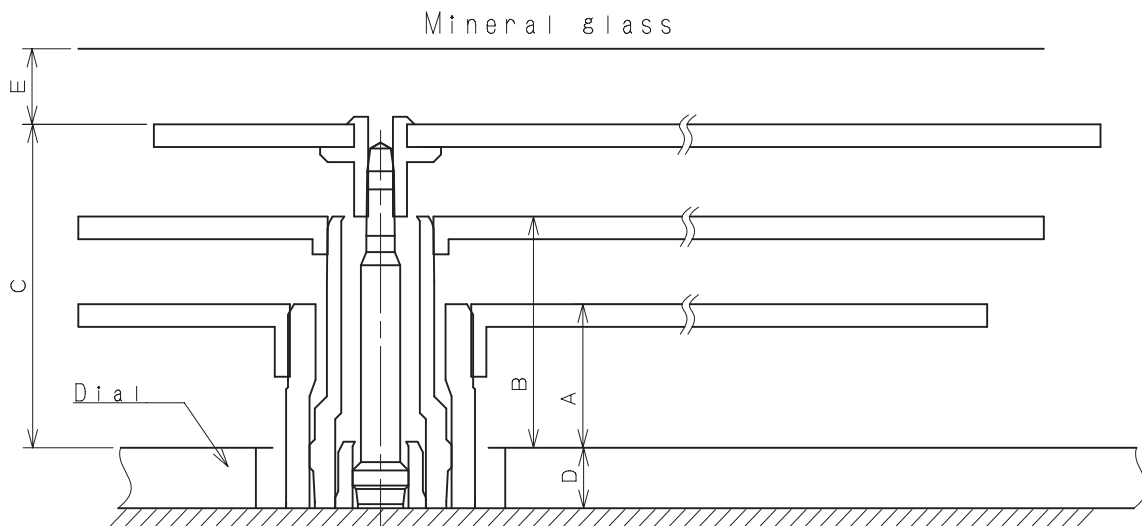

	A	B	C	D	E
TYPE M 一般針高	60	118	179	40	50
TYPE L 高針	50	108	169	85	50

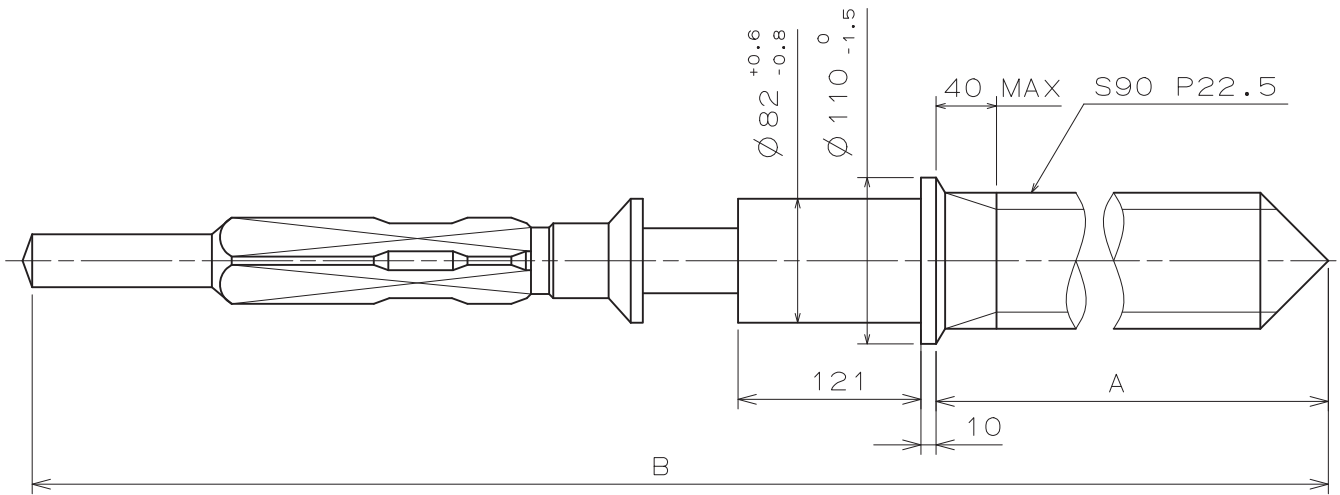

	Part No.	A	B
TYPE A	0351 177	1371	1969
TYPE B	0351 122	1947	2545

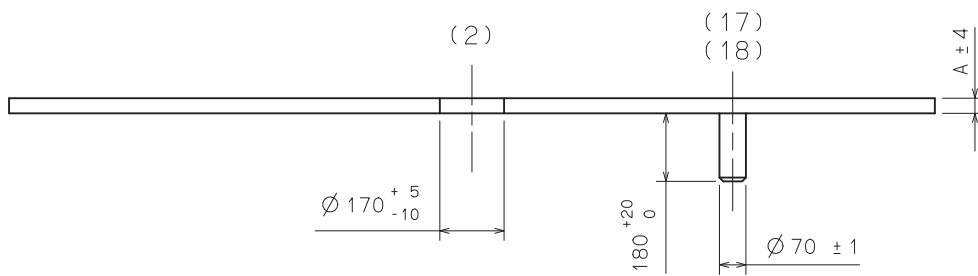
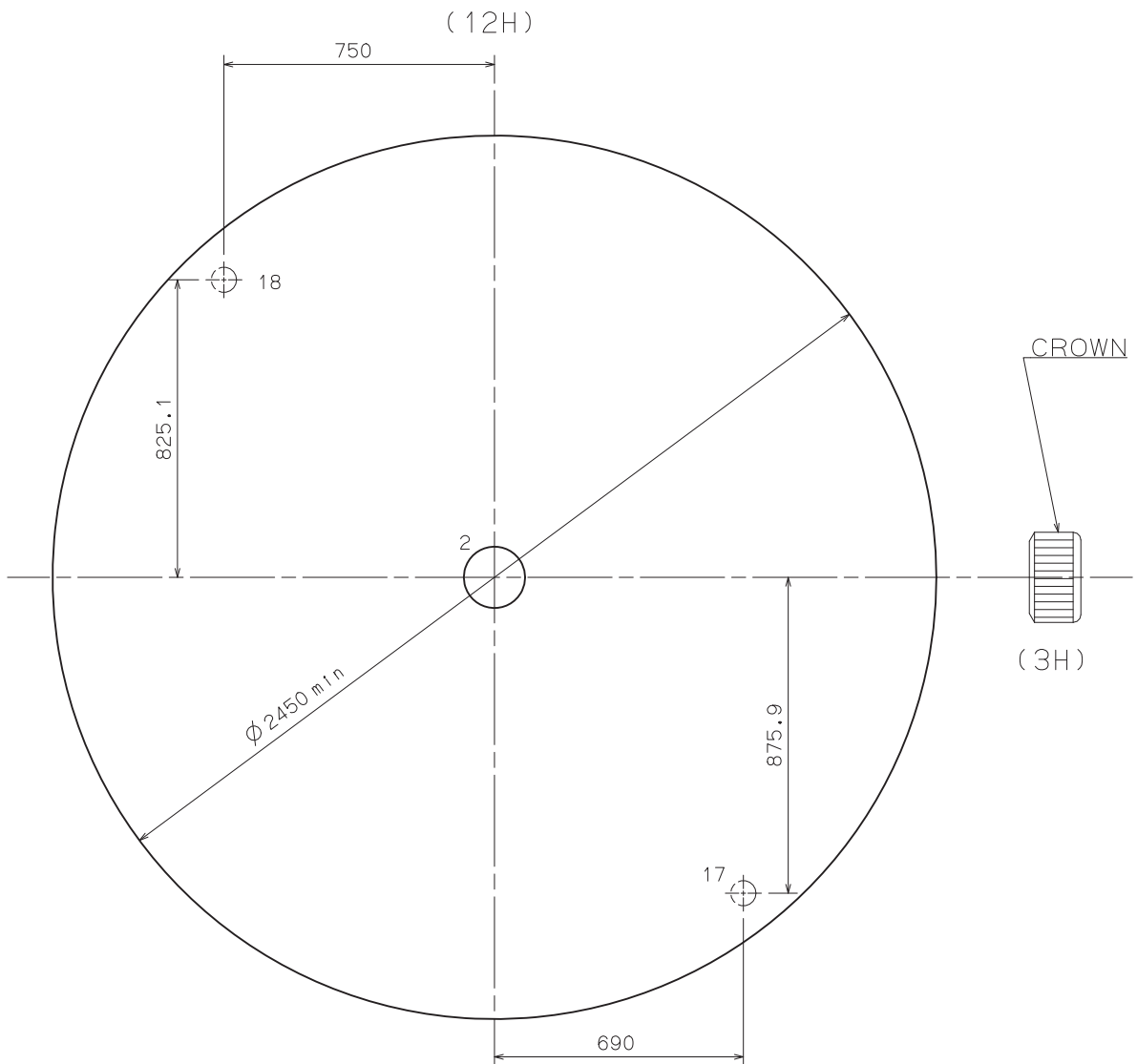

	TYPE M	TYPE L
A	40	85

Casing Ring

VH31A

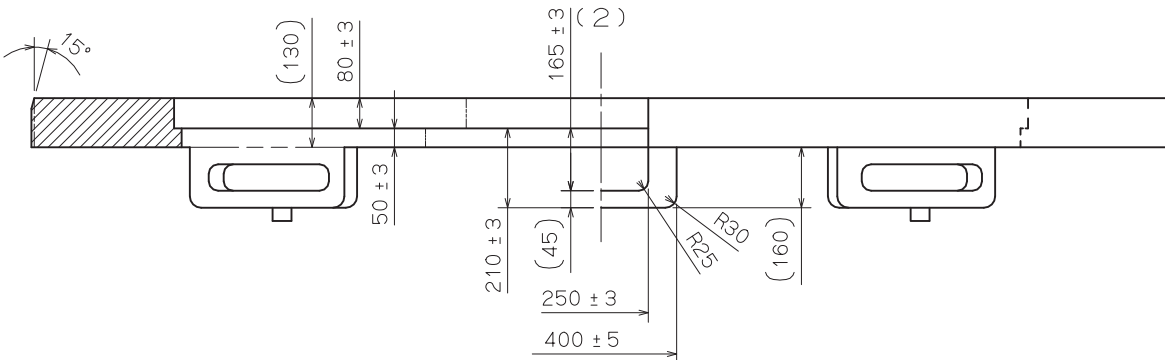
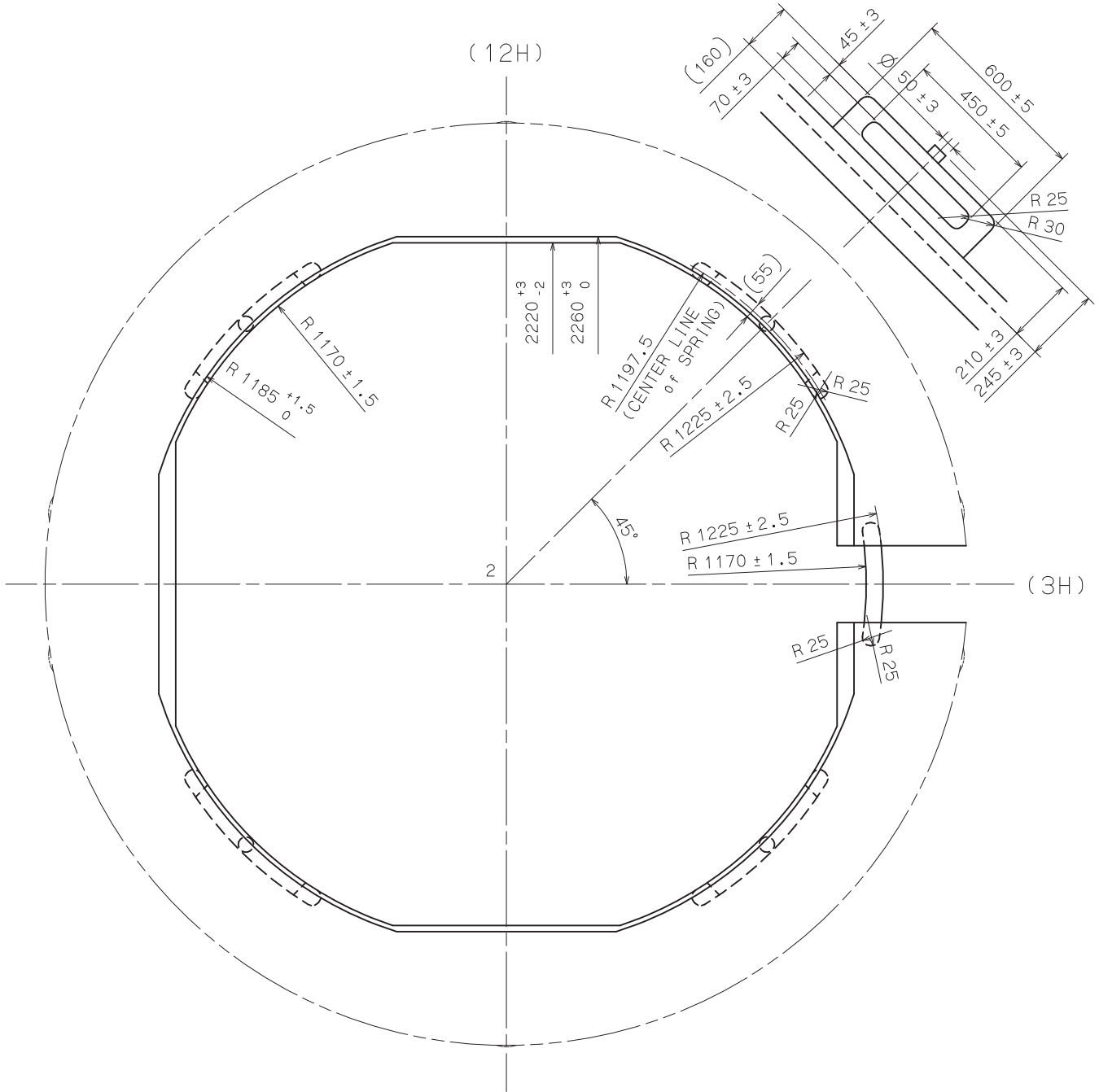

SECTIONAL VIEW of 12H DIRECTION

SIDE VIEW from 3H DIRECTION

Unit : 1=1/100mm

Version : 1

Assembly Plan

VH31A

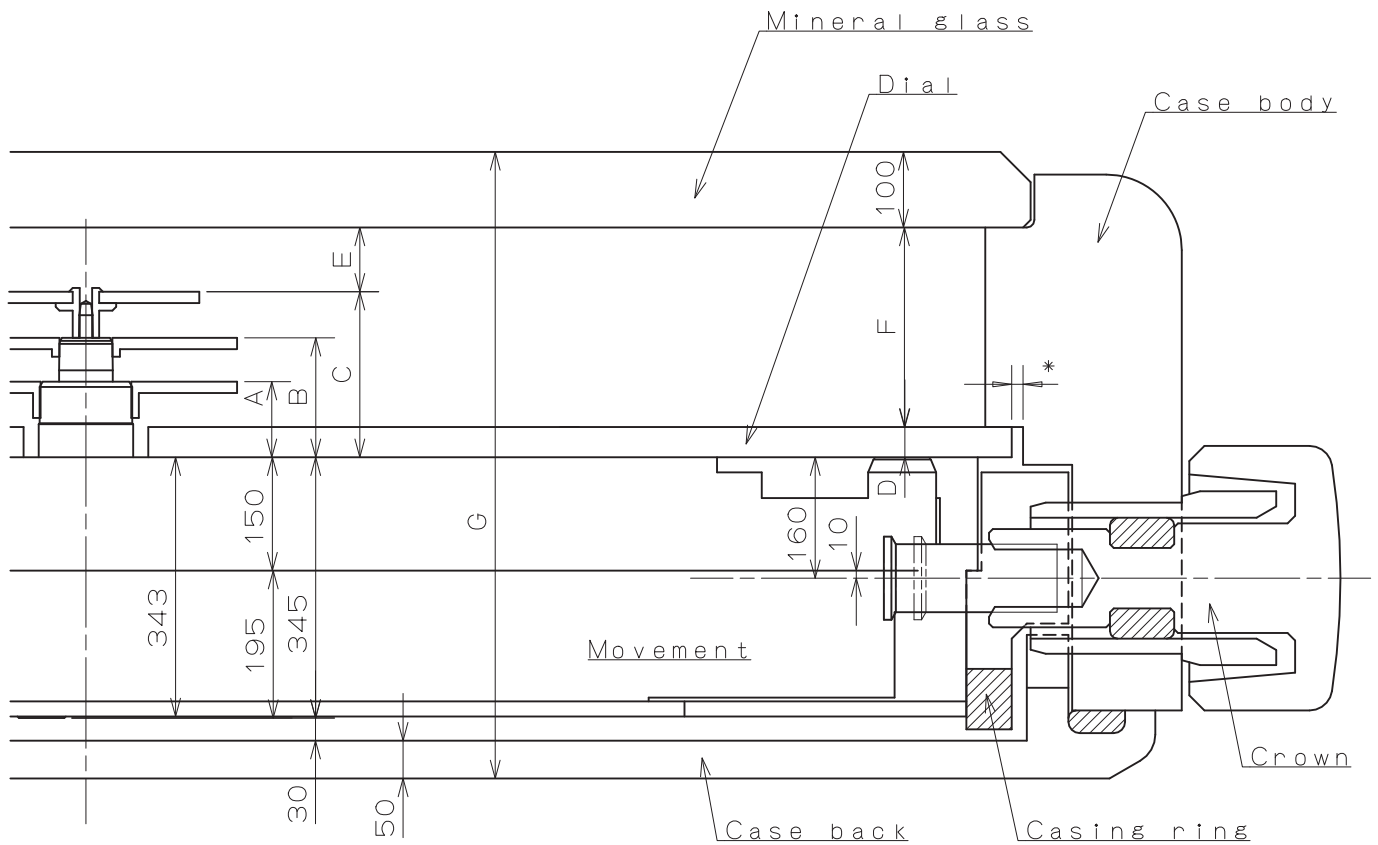

	A	B	C	D	E	F	G
TYPE M	100	158	219	40	50	229	794
TYPE L	135	193	254	85	50	219	829

*Recommended dimension (Clearance of dial and case body): 15

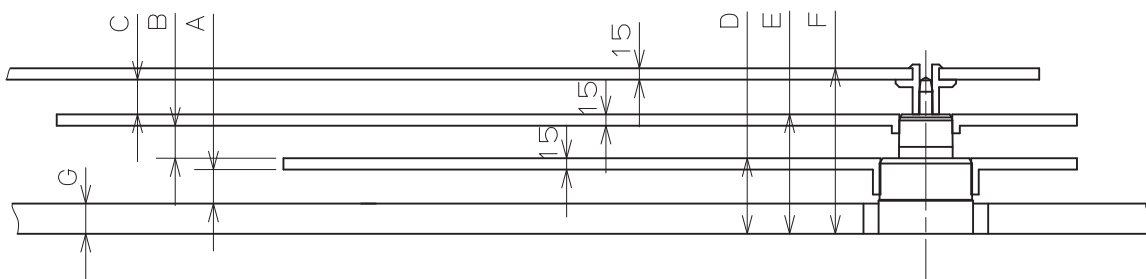

	A	B	C	D	E	F	G
TYPE M	45	43	46	100	158	219	40
TYPE L	35	43	46	135	193	254	85

Unit : 1=1/100mm

Version : 1

SECOND

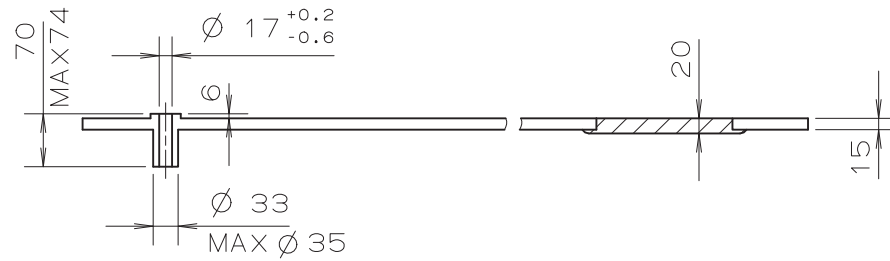

MINUTE

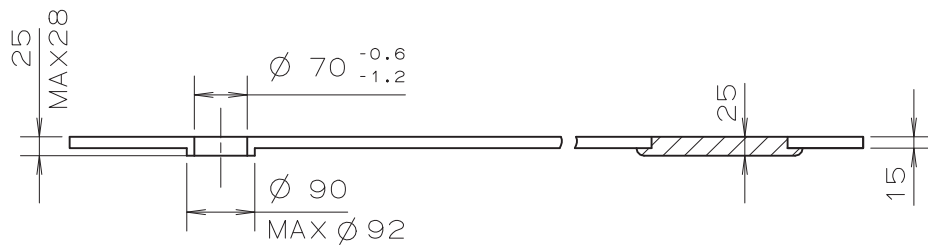

HOUR

