

DH1~DH2=25816 (±20)
 Stroke for PB
 must be minimum
 600 [$+200$] μm

| Coordinates | | | |
|-------------|--------|--------|-----|
| Mark | X | Y | R |
| GM | 0 | 0 | — |
| DH1 | 3000 | 13000 | — |
| DH2 | 2100 | -12800 | — |
| a1 | 3441 | 14908 | 430 |
| a2 | 1865 | 15186 | 430 |
| a3 | -15151 | 2129 | 430 |
| a4 | -15291 | 535 | 430 |
| a5 | 10434 | -11190 | 430 |
| a6 | 9208 | -12219 | 430 |

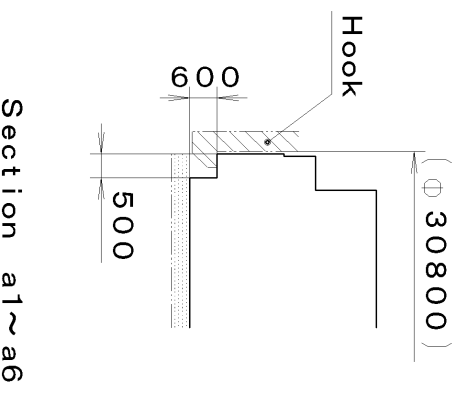
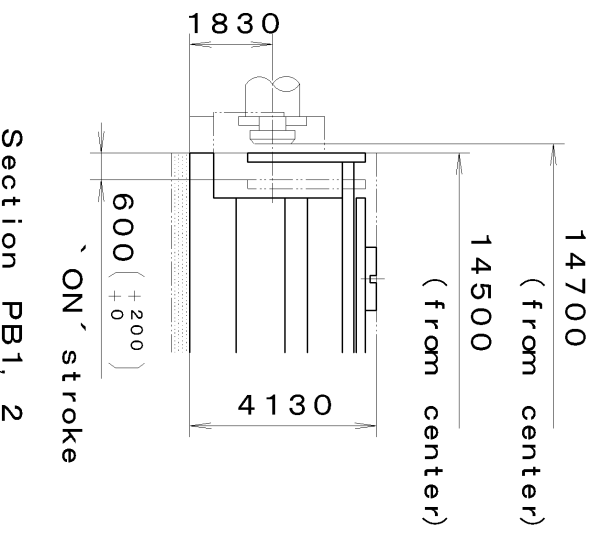
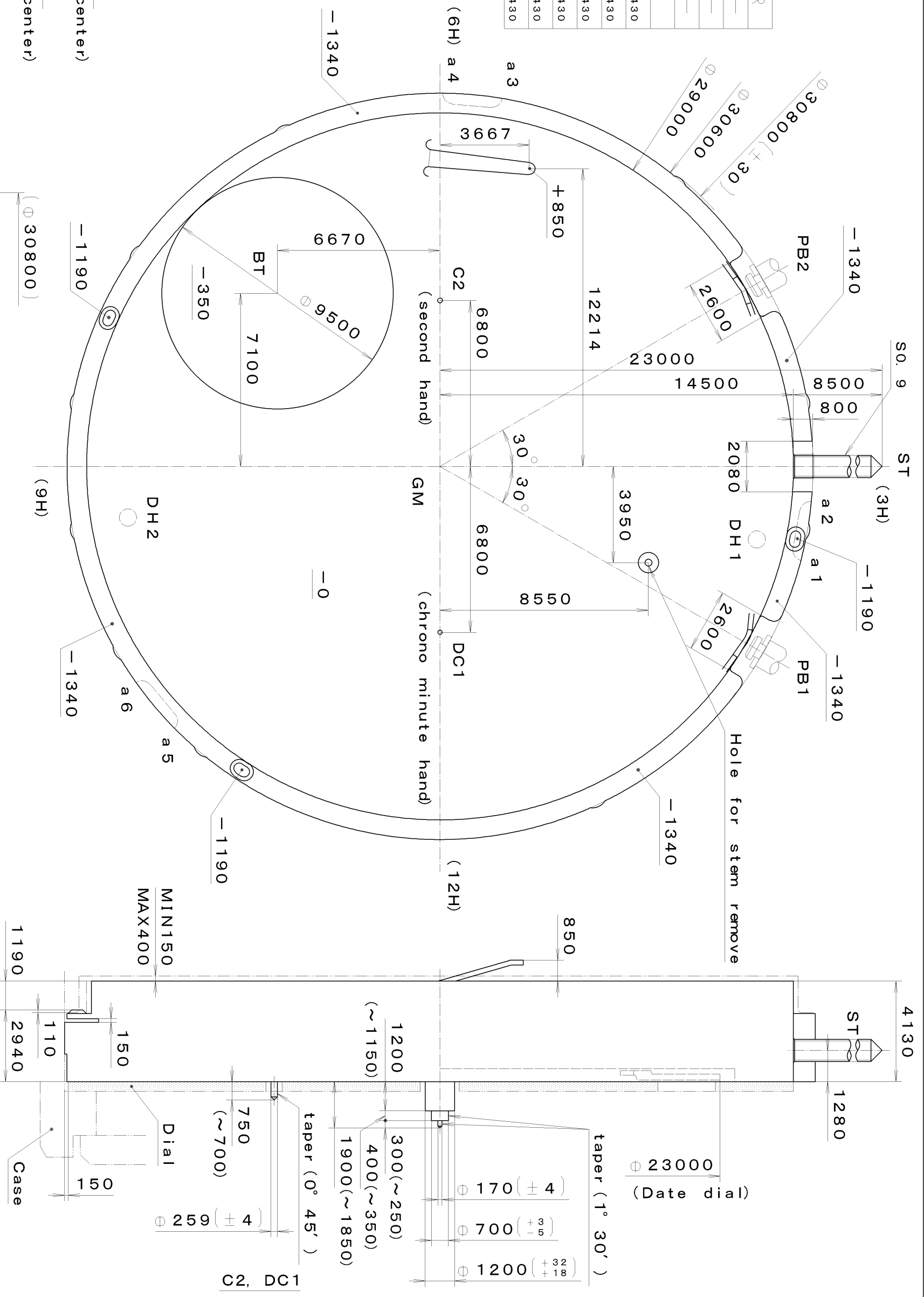

| Quantity | Unit | 1/1000 mm | Cal. No. : OS11 |
|--------------------|----------|-----------|------------------------|
| △ | Scale | 6:1 | Parts: |
| △ | Date | | Name: Frame for Case |
| △ | Drawn | | Drawing No. : OS11C000 |
| △ | Checked | T. Hiruta | |
| △ | Approved | | |
| Material | | | |
| Heat Treatment | | | |
| Hardness | | | |
| Plating | | | |
| General Tolerances | | | |
| Dimensions | | | |
| Angles | | | |

MIYOTA

This drawing is provisional and subject to our reconfirmation and/or revision without notice.

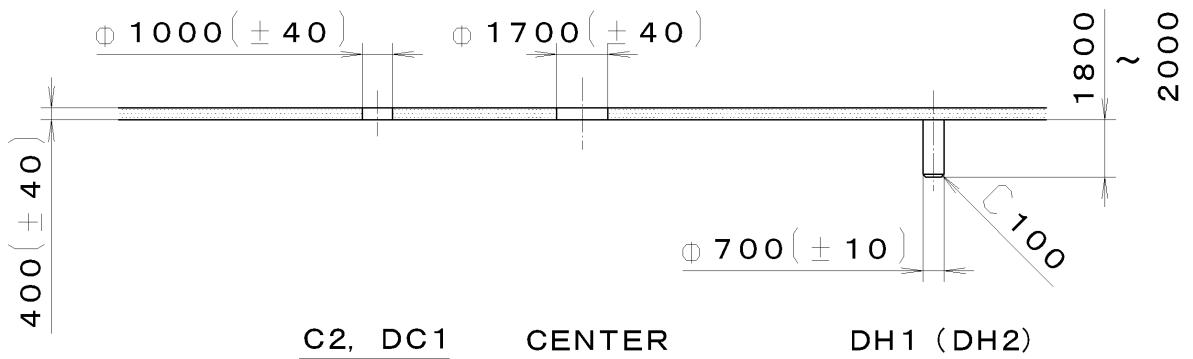
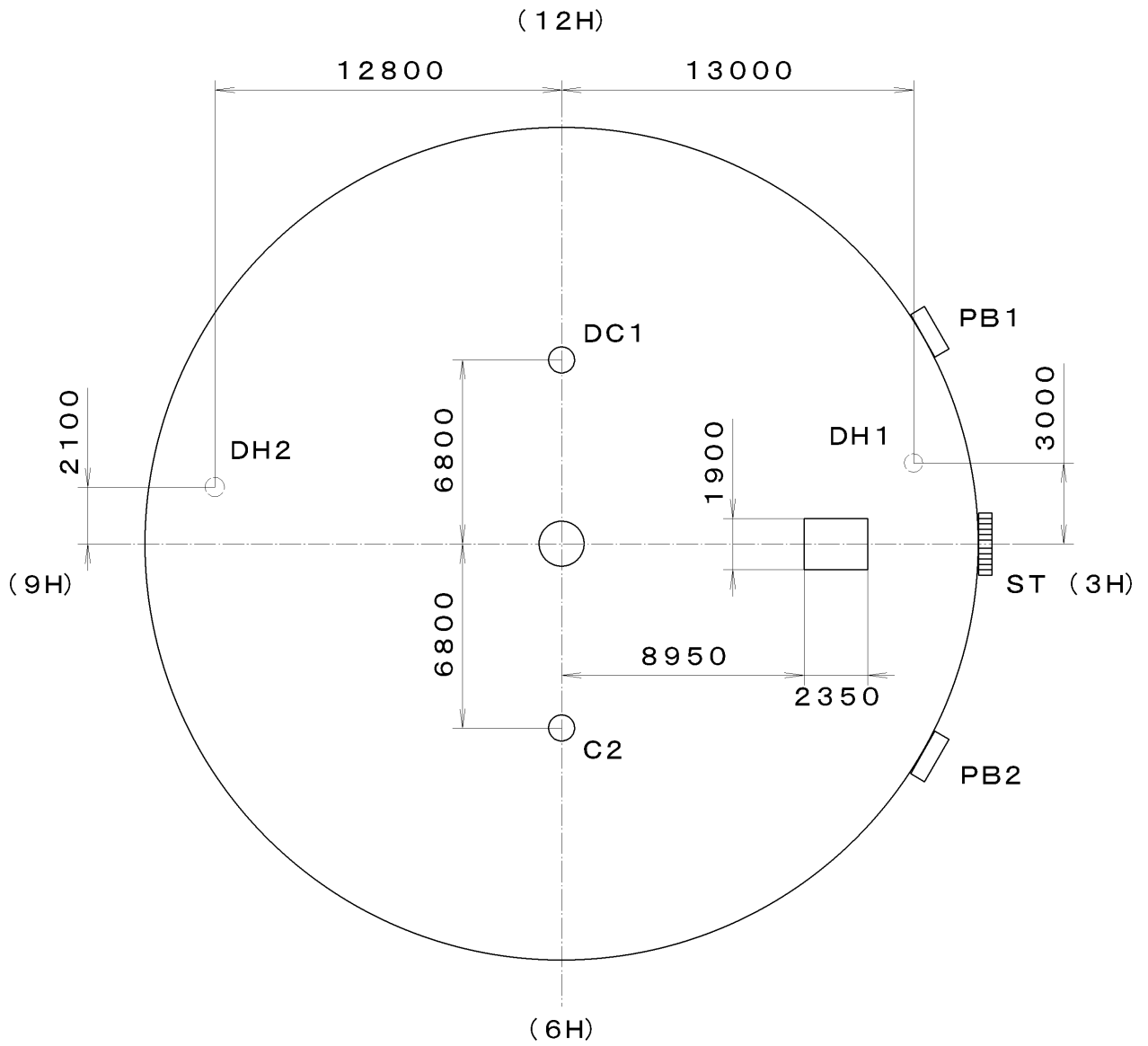

*** T I P W OS11-00A (01) *** (2100 1121) 03-01-08

| | | | | |
|----------------|--|--------------------|-----------|-------------------------------|
| △7 | | Quantity | | Cal. No. : OS11-00A |
| △6 | | Unit | 1/1000 mm | |
| △5 | | Scale | 4:1 | Parts: |
| △4 | | Date | | |
| △3 | | Drawn | | |
| △2 | | Checked | T. Hiruta | Name: |
| △1 | | Approved | | Indications for Dial |
| Material | | | | Drawing No. : OS11D000 |
| Heat Treatment | | General Tolerances | | MIYOTA |
| Hardness | | Dimensions | | |
| Plating | | Angles | | |

This drawing is provisional and subject to our reconfirmation and/or revision without notice.

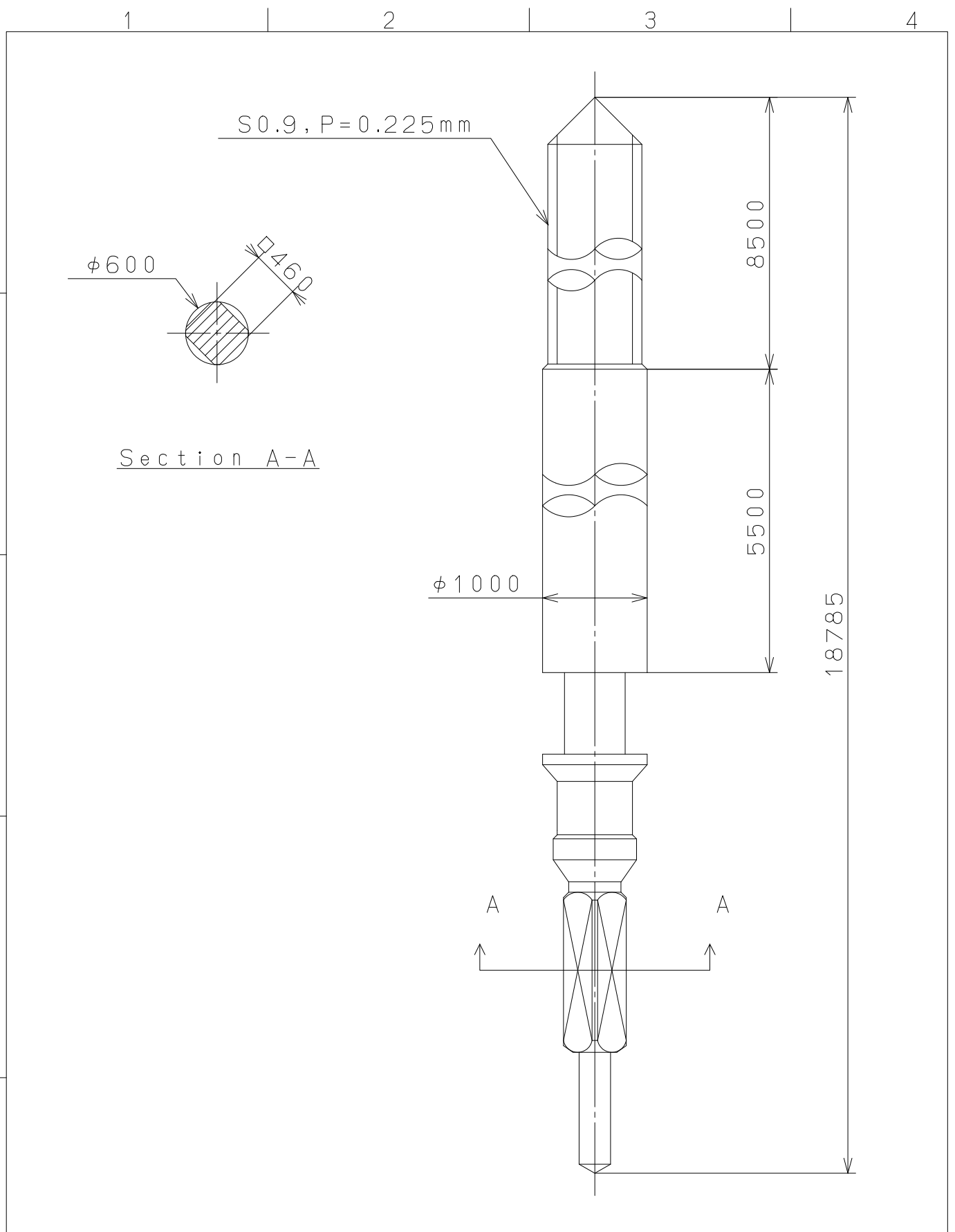

| | | | | | |
|----------------|------|-------------|--------------------|--------------------------------------|-----------------------|
| △5 | | | Quantity | | Cal.NO.: |
| △4 | | | Unit | 1 / 1000 mm | |
| △3 | | | Scale | 20 : 1 | Parts No.: |
| △2 | | | Date | | 065-453 |
| △1 | | | Drawn | | |
| Mark | Date | Description | Appro. | Checked | E. Murakami |
| Alterations | | | Approved | Name: SETTING STEM | |
| Material | | | | | Drawing No.: 4530S000 |
| Heat Treatment | | | | | MIYOTA |
| Hardness | | | | | |
| Plating | | | | | |
| | | | General Tolerances | CITIZEN WATCH CO., LTD. TOKYO, JAPAN | |
| | | | Dimensions | | |
| | | | Angles | | |