

Watch Movement Specification and Drawing

2 Hands Multi-eye Movement

VD78A

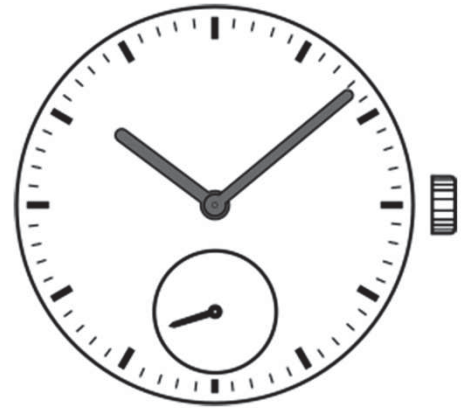

Movement Size: **10 1/2"**
 Diameter: **Φ23.70mm**
 Height: **3.45mm**

Items	Ver.	Items	Ver.
Specification	1		
Appearance	1		
Casing	1		
Hand Fitting	1		
Hand Setting Stem	1		
Dial	1		
Casing Ring	1		
Assembly Plan	1		
Hands	1		

CAL.VD78A 10½ Ligne Quartz Movement

Two Hands with 1 Eye Small Second Hand

1. FUNCTION

· Jewel	0 jewel
· Accuracy	Less than ± 20 seconds / month (Normal temperature range)
· Battery life	Approx. 3 years
· Regulation hands unbalance	Hour hand : Less than $0.60 \mu\text{N}\cdot\text{m}$ (60 mg·mm) Minute hand : Less than $0.60 \mu\text{N}\cdot\text{m}$ (60 mg·mm) Small hand : Less than $0.05 \mu\text{N}\cdot\text{m}$ (5 mg·mm) (Second hand)

2. USE AND TEST CONDITION

· Battery	SR626SW	(Recommended battery is SEIZAIKEN)
· Operation temperature range	From $- 5 \text{ }^\circ\text{C}$ to $+ 50 \text{ }^\circ\text{C}$	
· Antimagnetic	$\geq 1600 \text{ A / m}$	(Direct current magnetic field)
· Test of accuracy	10 seconds	(Duration of measurement)

*** All specifications are subject to change without notice.**

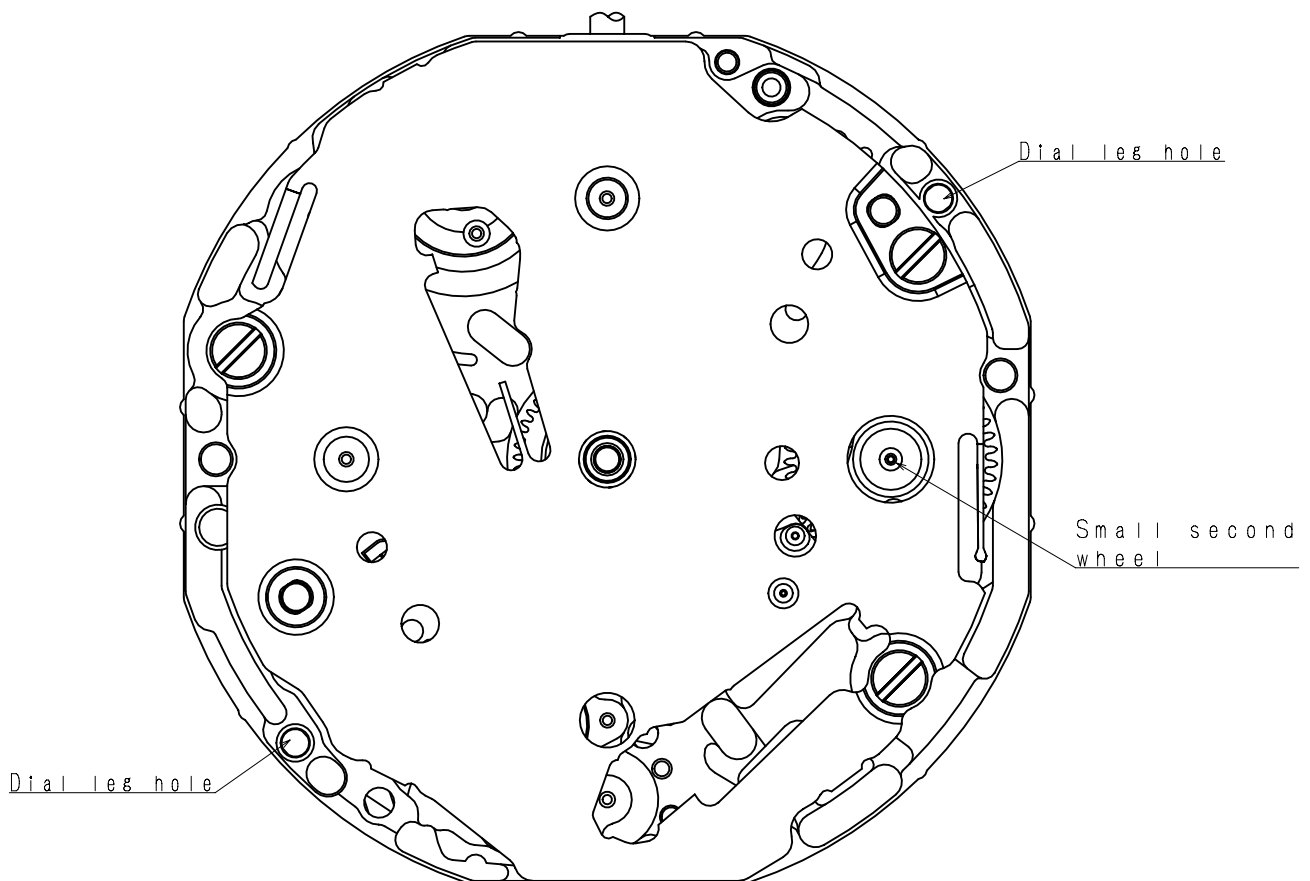
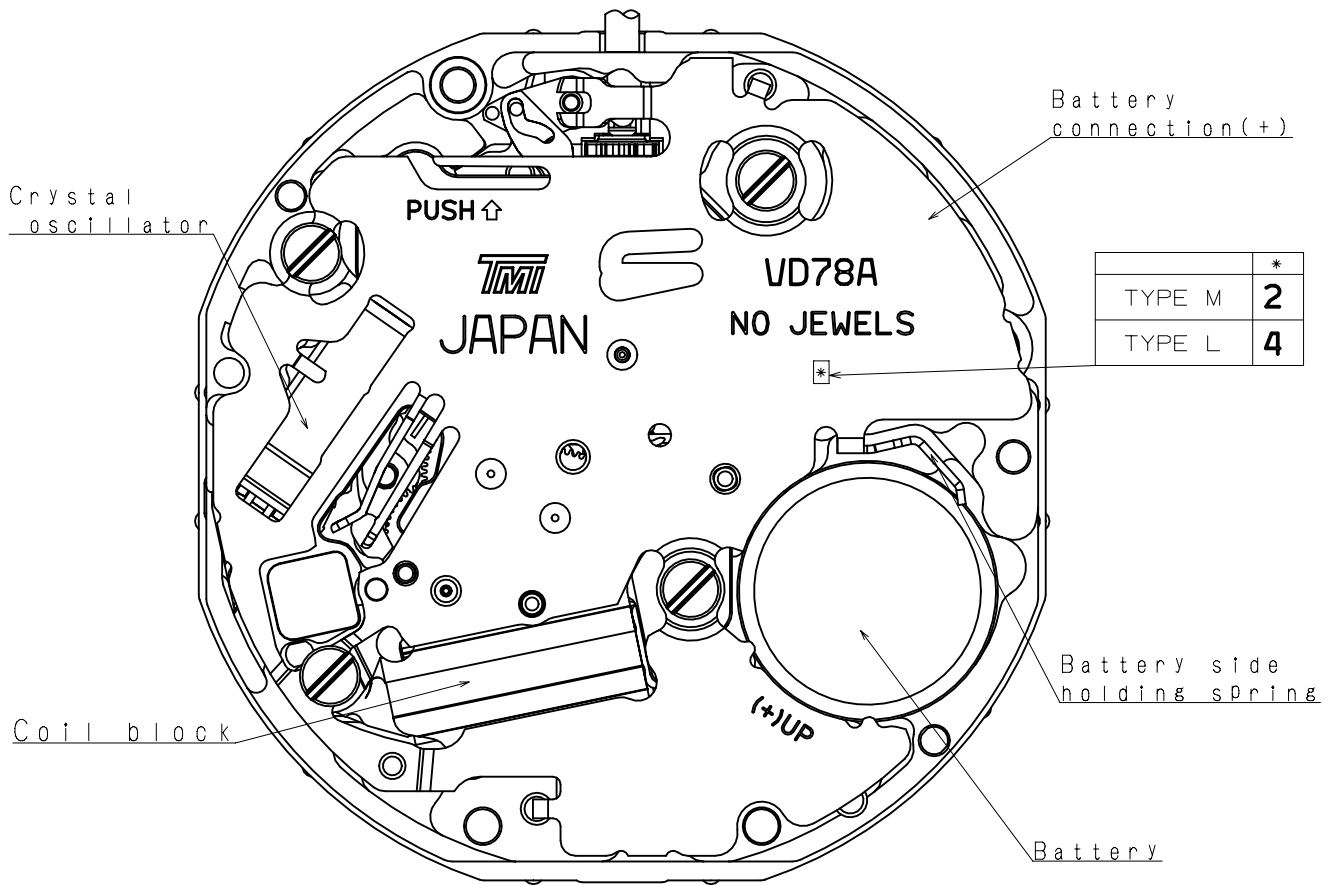

* Pull out stroke 44.8

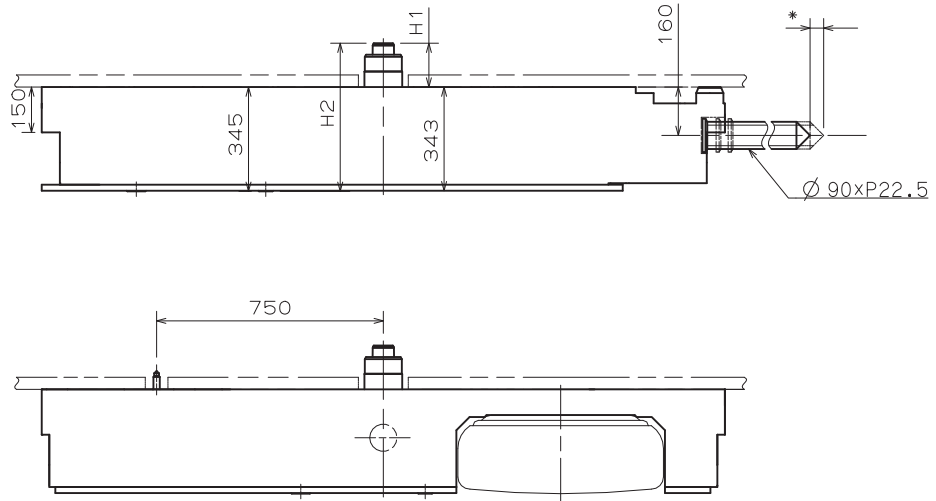

Center post 中心柱位		TYPE M	TYPE L
		一般針高	高針
Maximum height from main plate surface 與機芯平面的最大高度	H1	150	230
Total height incl. movement 機芯總高度	H2	495	575

Hand Setting Stem	TYPE A	TYPE B
L1	2436	3012

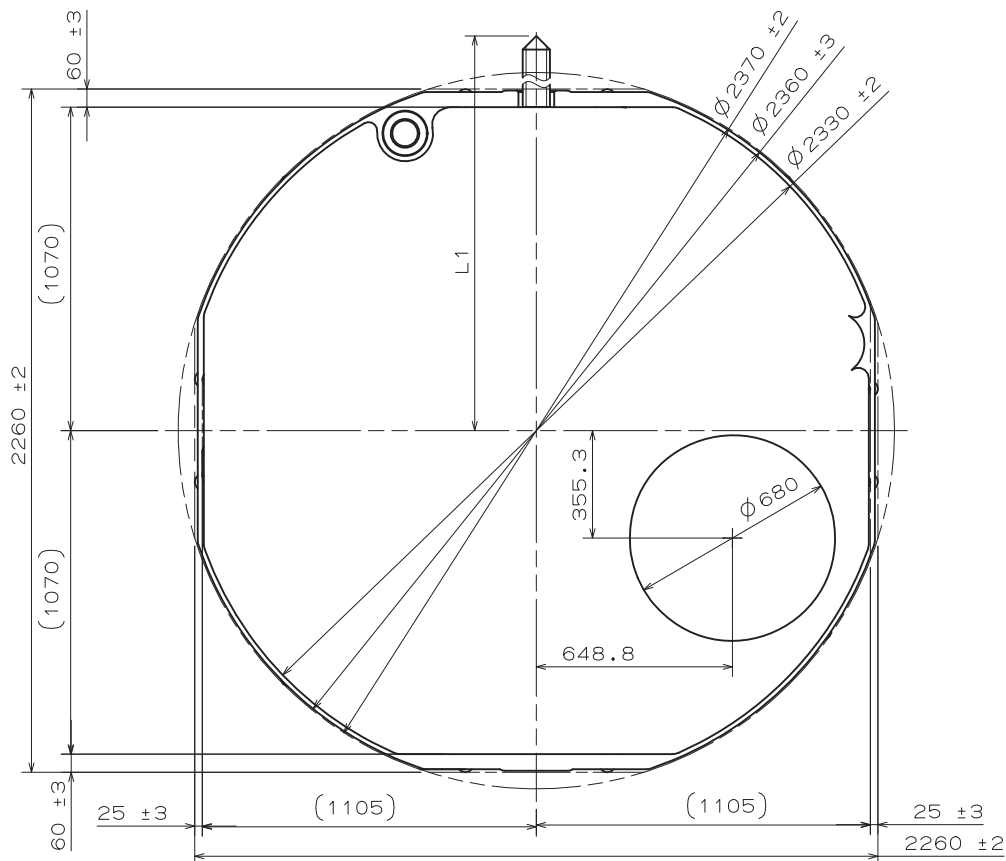

- * Hour hand unbalance $\leq 0.6 \mu\text{N}\cdot\text{m} (60\text{mg}\cdot\text{mm})$
- * Minute hand unbalance $\leq 0.6 \mu\text{N}\cdot\text{m} (60\text{mg}\cdot\text{mm})$
- * Small second hand unbalance $\leq 0.05 \mu\text{N}\cdot\text{m} (5\text{mg}\cdot\text{mm})$

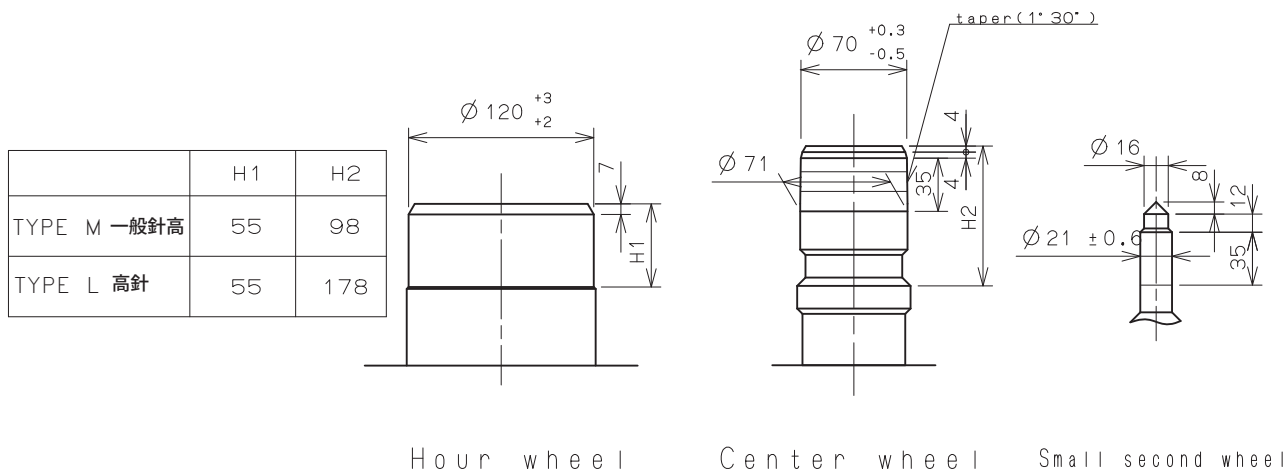

Part name	Part No.	
	TYPE M 一般針高	TYPE L 高針
Hour wheel 時針輪	0273 169	0273 035
Center wheel 分針輪	0221 069	0221 076
Small second wheel 小秒針輪	0240 169	0240 015

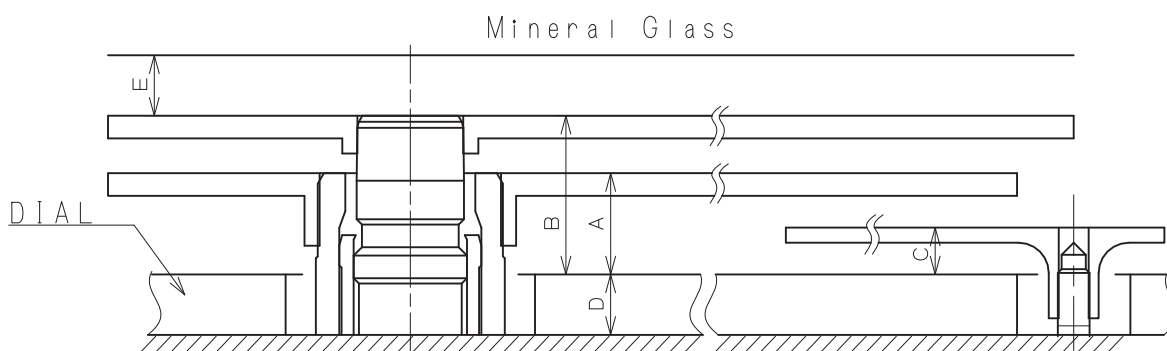

	A	B	C	D	E
TYPE M 一般針高	72	110	31	40	35
TYPE L 高針	95	145	41	85	40

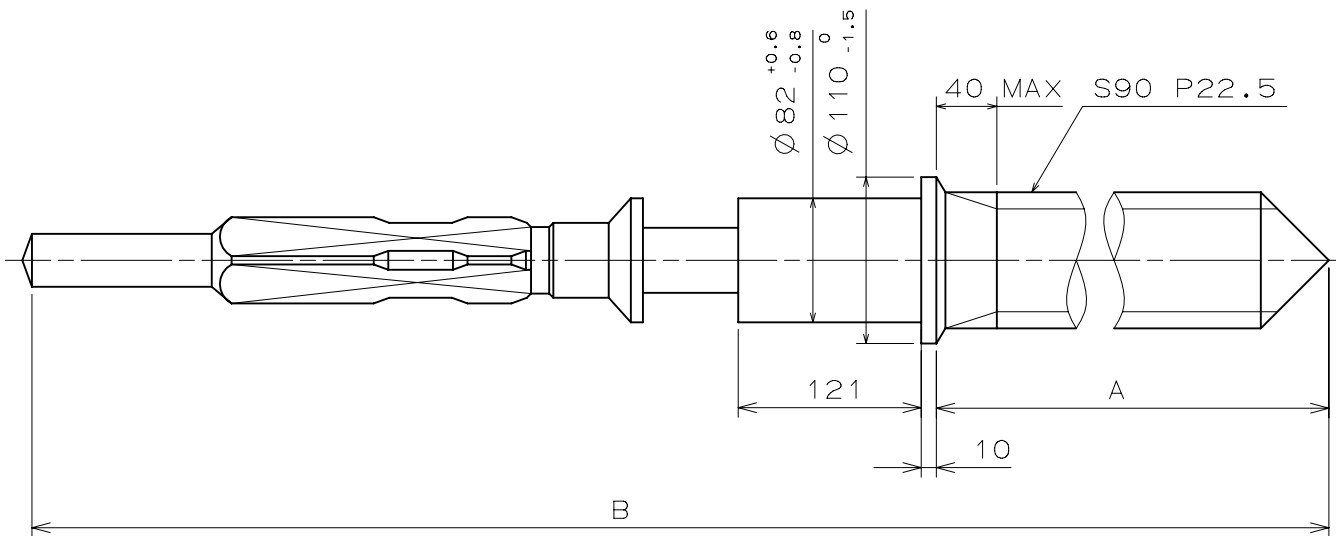

	Part No.	A	B
TYPE A	0351 177	1371	1969
TYPE B	0351 122	1947	2545

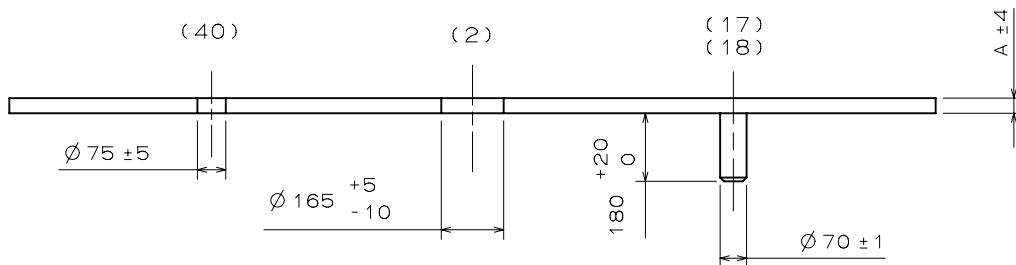
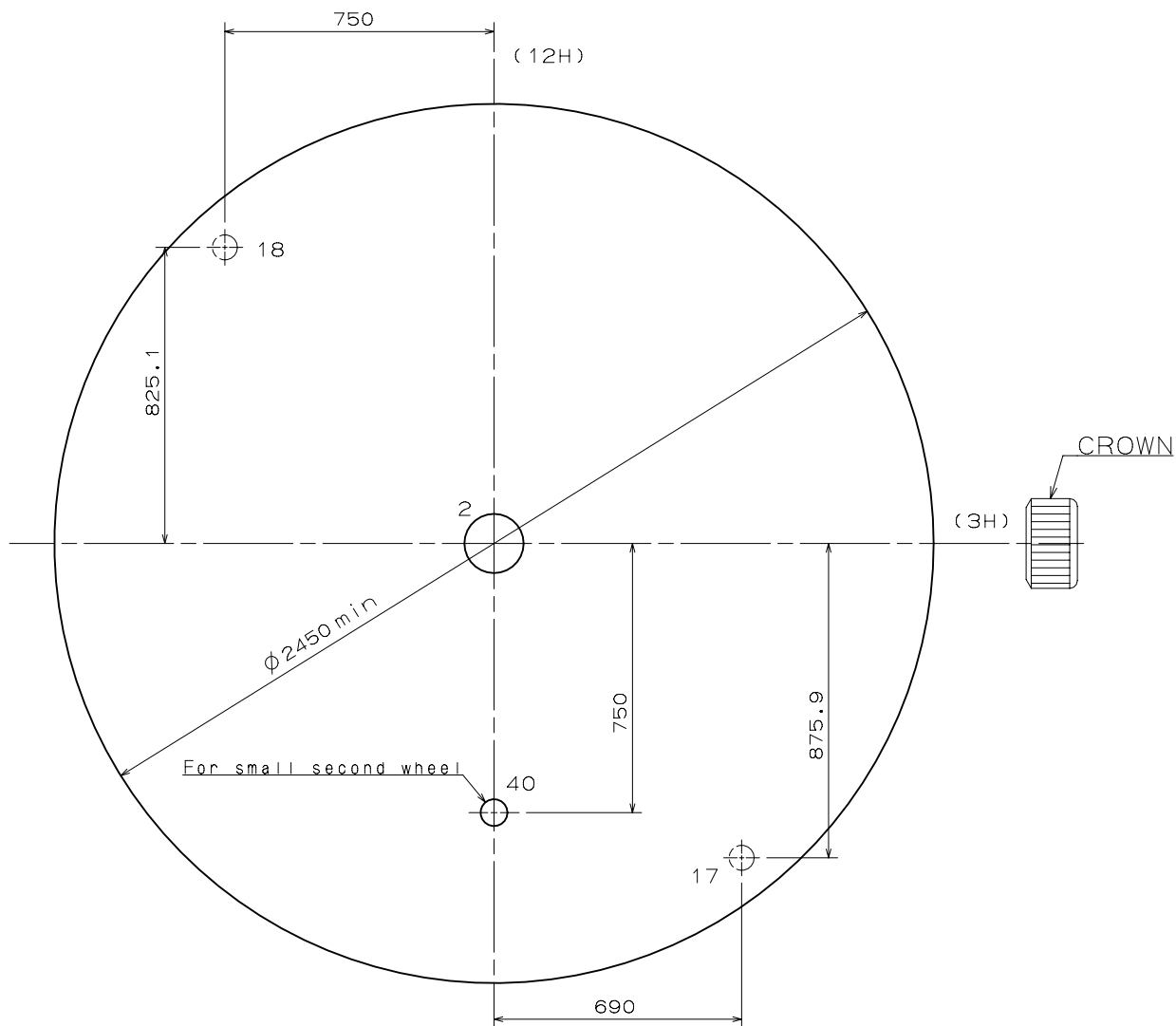

	TYPE M	TYPE L
A	40	85

Casing Ring

VD78A

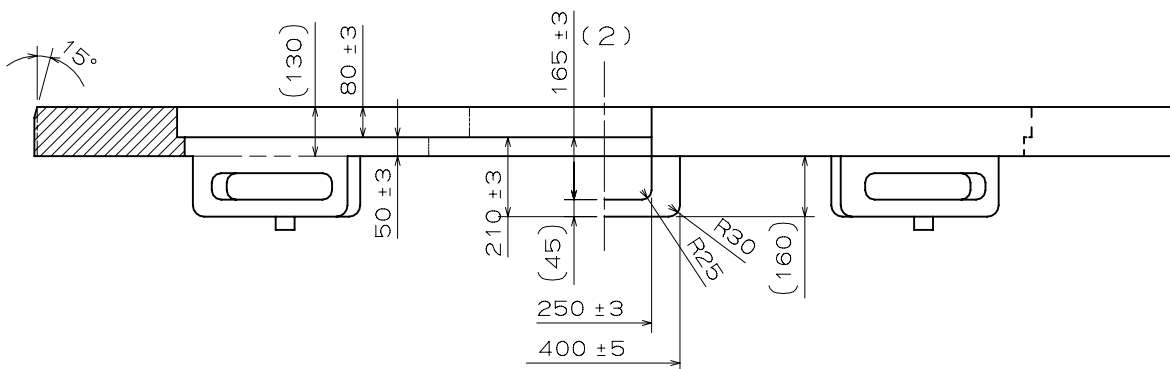
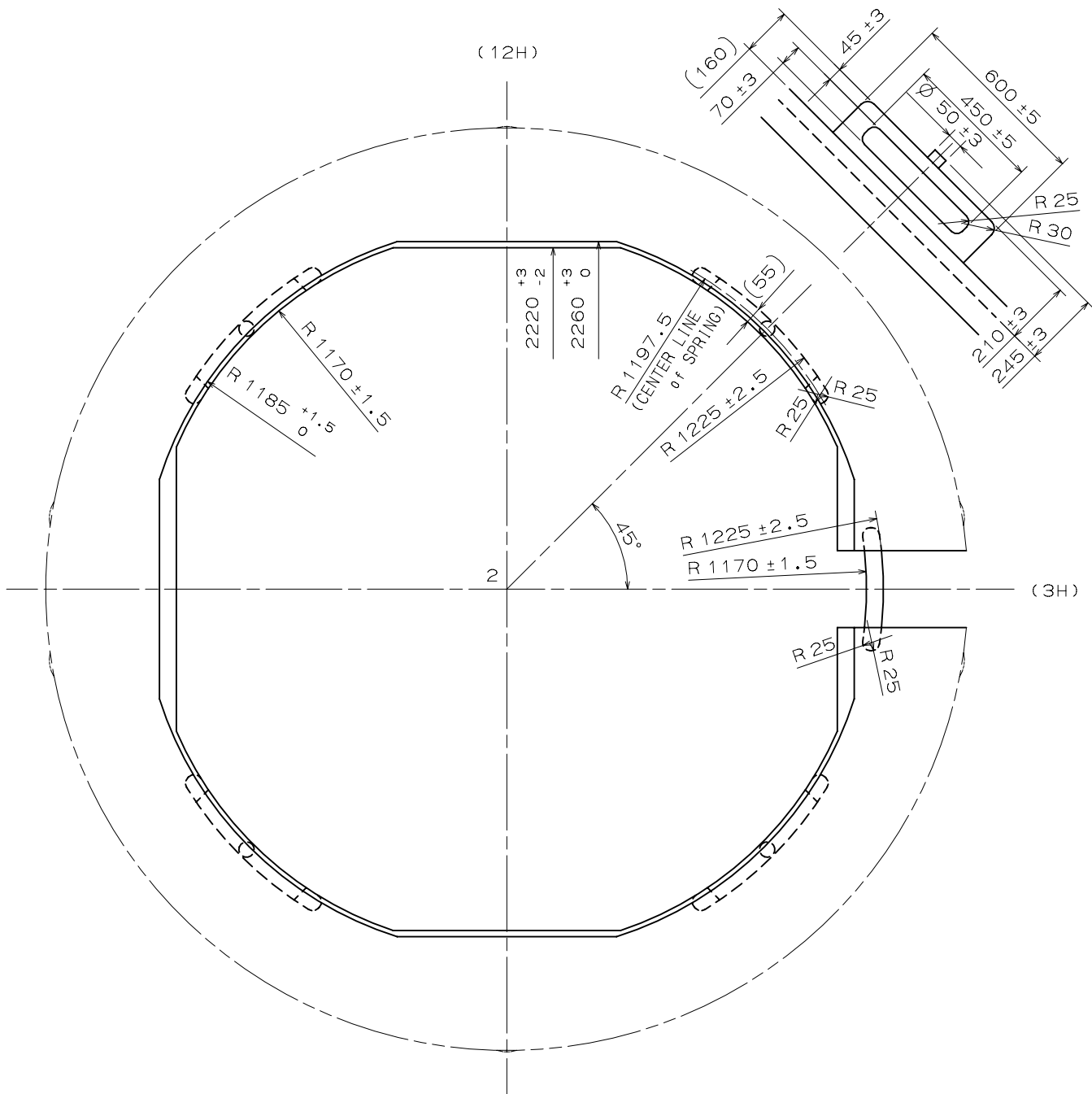

SECTIONAL VIEW of 12H DIRECTION

SIDE VIEW from 3H DIRECTION

Unit : 1=1/100mm

Version : 1

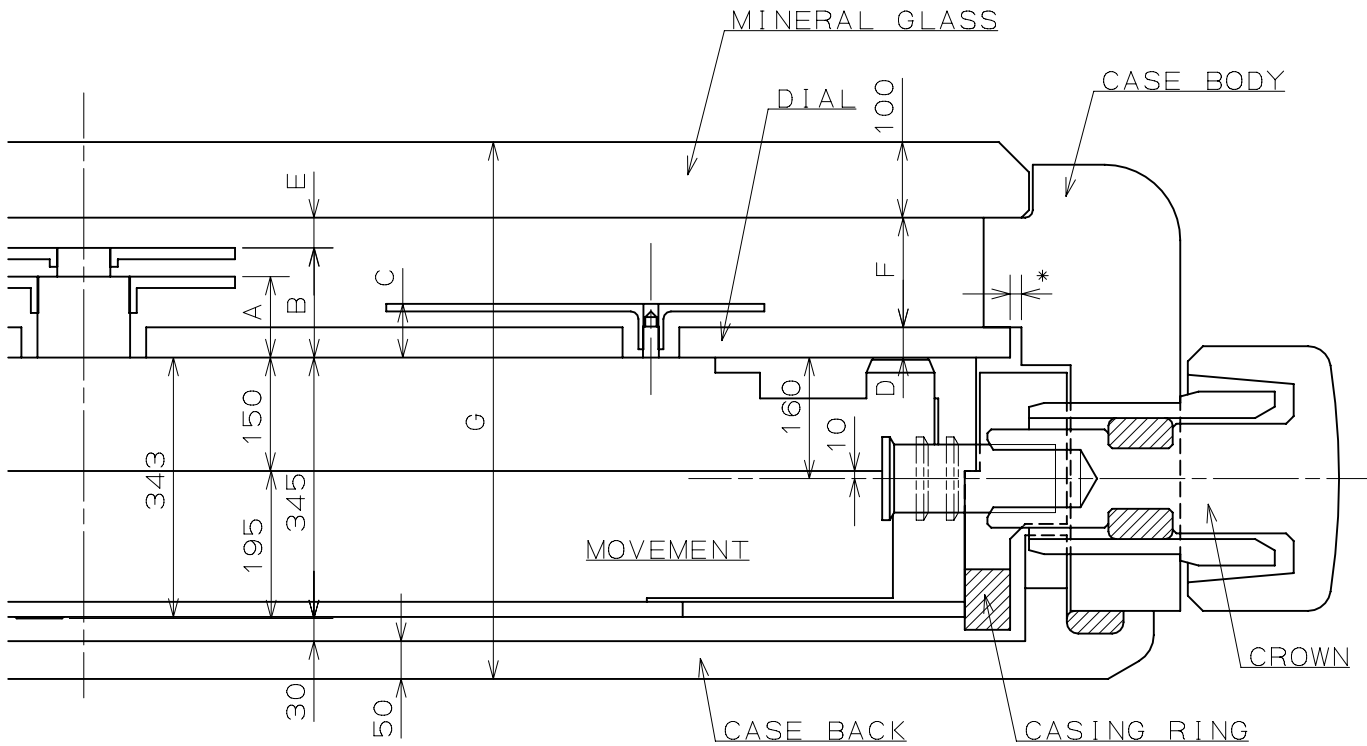

	A	B	C	D	E	F	G
TYPE M	112	150	71	40	35	145	710
TYPE L	180	230	126	85	40	185	795

*Recommended Dimension(Clearance of DIAL and CASE BODY):15

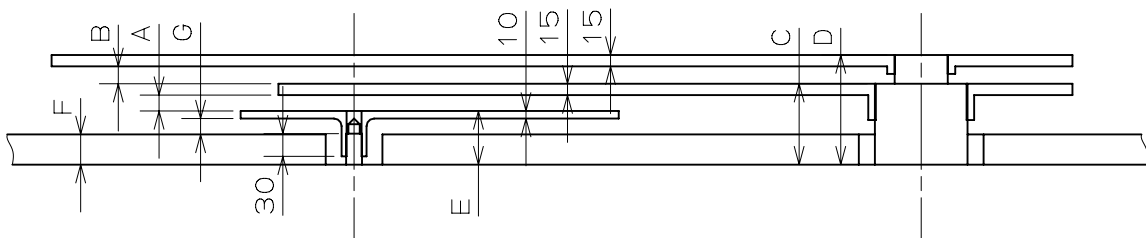

	A	B	C	D	E	F	G
TYPE M	26	23	112	150	71	40	21
TYPE L	39	35	180	230	126	85	31

TYPE M

MINUTE

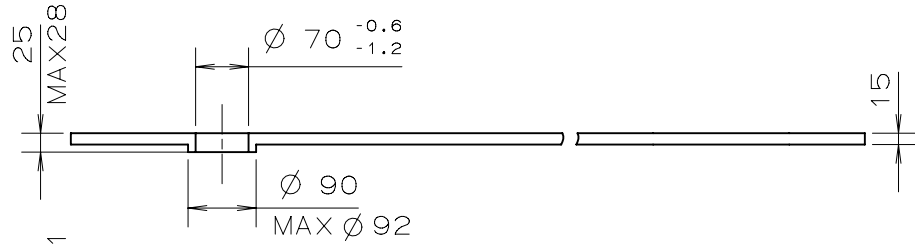

HOUR

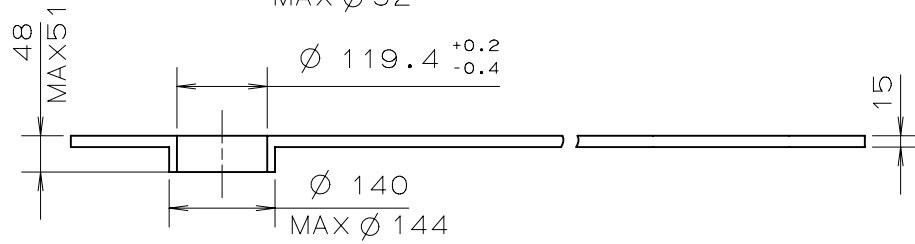

SMALL SECOND

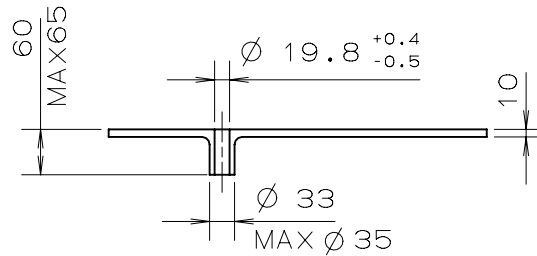

TYPE L

MINUTE

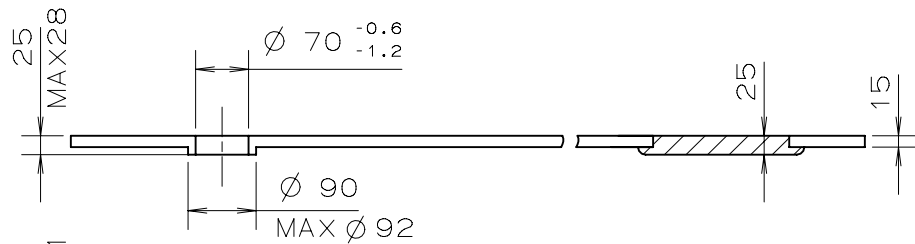

HOUR

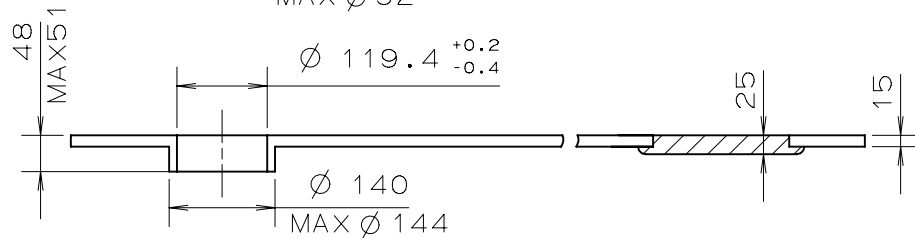

SMALL SECOND

