

This drawing is provisional and subject to our reconfirmation and/or revision without notice.

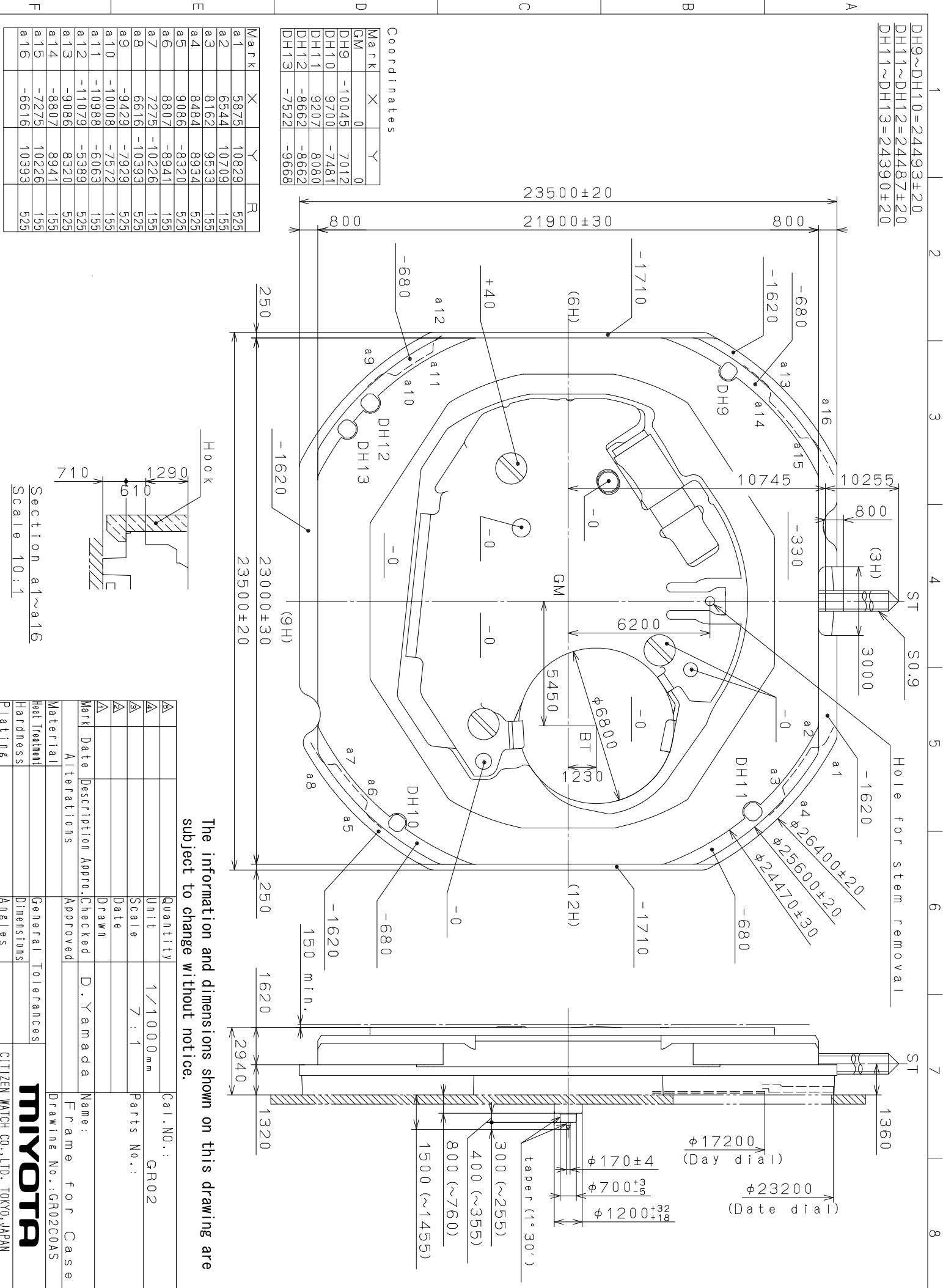

Coordinates

Mark	X	Y
GM	0	0
DH9	-10045	7012
DH10	9700	-7481
DH11	9207	8080
DH12	-8662	-8662
DH13	-7522	-9668

Mark	X	Y	R
a1	5875	10829	525
a2	6544	10709	155
a3	8162	9533	155
a4	8484	8934	525
a5	9086	-8320	525
a6	8807	-8941	155
a7	7275	-10226	155
a8	6616	-10393	525
a9	-9429	-7929	525
a10	-10008	-7572	155
a11	-10988	-6063	155
a12	-11079	-5389	525
a13	-9086	8320	525
a14	-8807	8941	155
a15	-7275	10226	155
a16	-6616	10393	525

The information and dimensions shown on this drawing are subject to change without notice.

Material	Alterations	Quantity	Unit	Call. No.:
Hardness	Date	1	1/1000 mm	GR02
Plating	Drawn	7	7 : 1	Parts No.:
	Checked			
	Approved			
	Name:		D. Yamada	
	Frame for Case		Drawing No.: GR02C0AS	
	General Tolerances		Miyota	
	Dimensions		CITIZEN WATCH CO., LTD. TOKYO, JAPAN	
	Angles			

This drawing is provisional and subject to our reconfirmation and/or revision without notice.

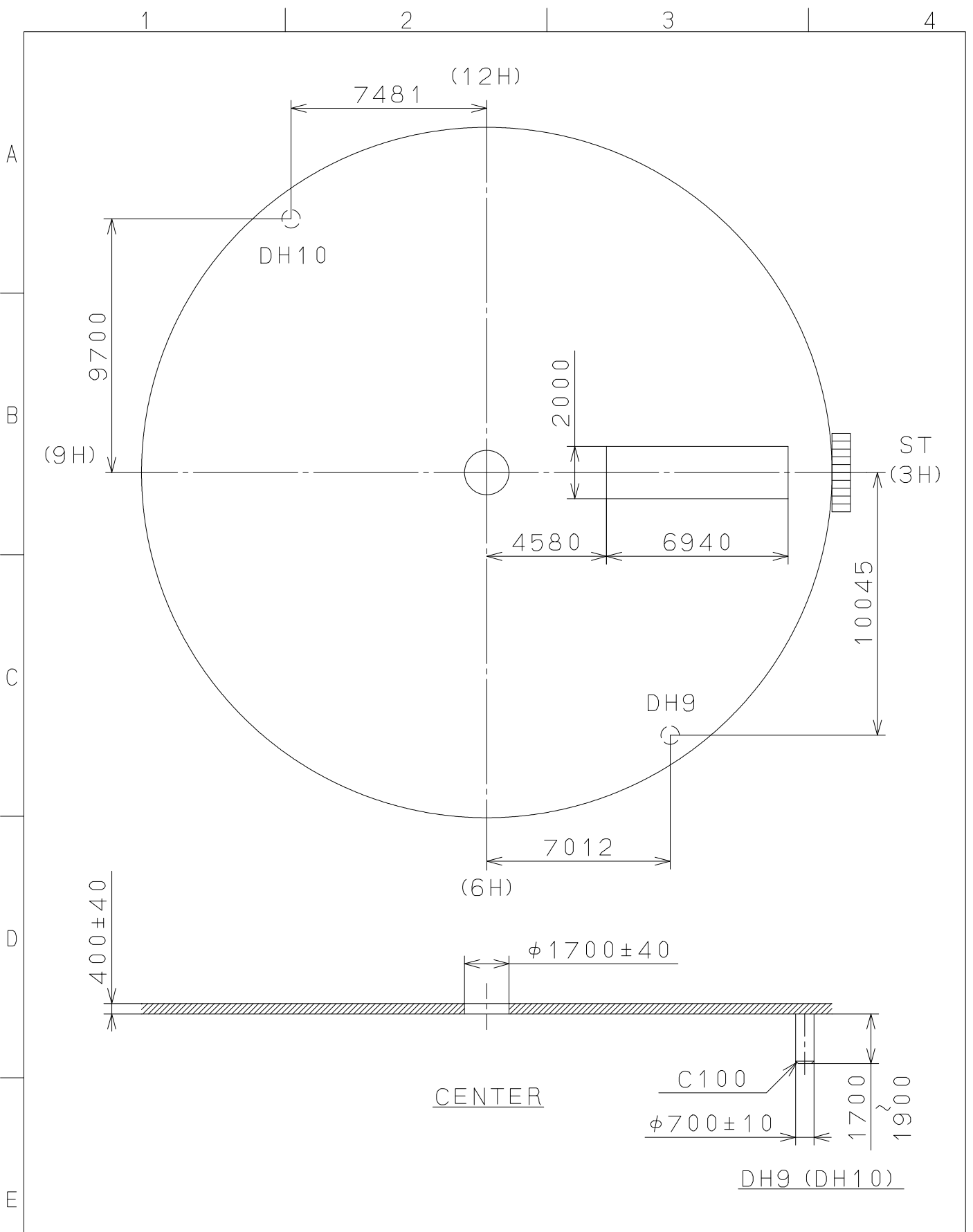

△5			Quantity		Cal.NO.:	
△4			Unit	1/1000 _{mm}		GR02-10A
△3			Scale	5 : 1	Parts No.:	
△2			Date			
△1			Drawn			
Mark	Date	Description	Appro.	Checked	D. Yamada	Name:
Alterations			Approved	Indications for Dial		
Material					Drawing No.: GR02DOAS	
Heat Treatment					MIYOTA CITIZEN WATCH CO., LTD. TOKYO, JAPAN	
Hardness						
Plating						

This drawing is provisional and subject to our reconfirmation and/or revision without notice.

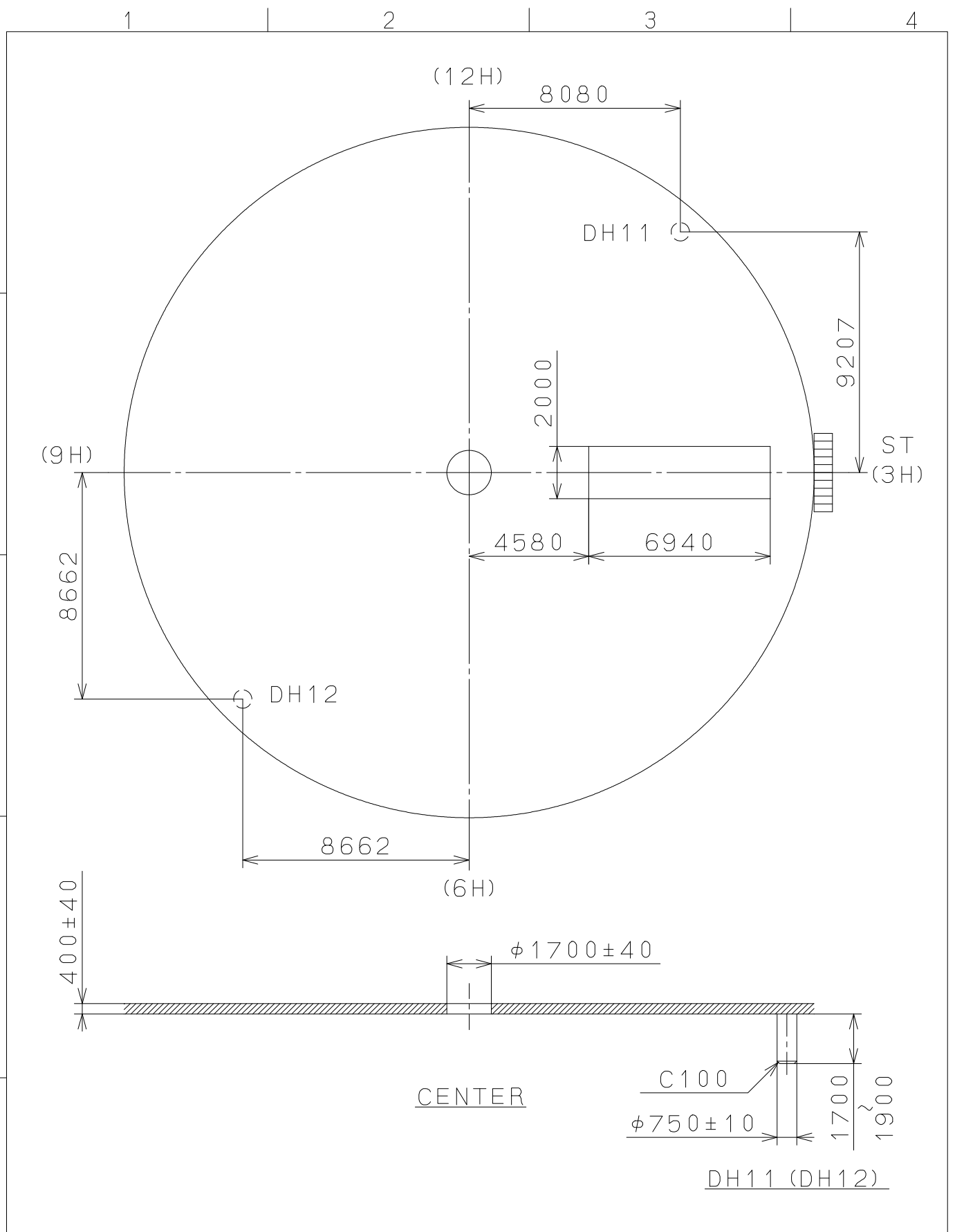

△5			Quantity		Cal.NO.:
△4			Unit	1/1000mm	GR02-10A
△3			Scale	5:1	Parts No.:
△2			Date		
△1			Drawn		
Mark	Date	Description	Appr.	Checked	Name:
		Alterations	Approved	D. Yamada	Indications for Dial
Material					Drawing No.: GR02D0BS
Heat Treatment			General Tolerances		MIYOTA
Hardness			Dimensions		
Plating			Angles		
					CITIZEN WATCH CO., LTD. TOKYO, JAPAN

This drawing is provisional and subject to our reconfirmation and/or revision without notice.

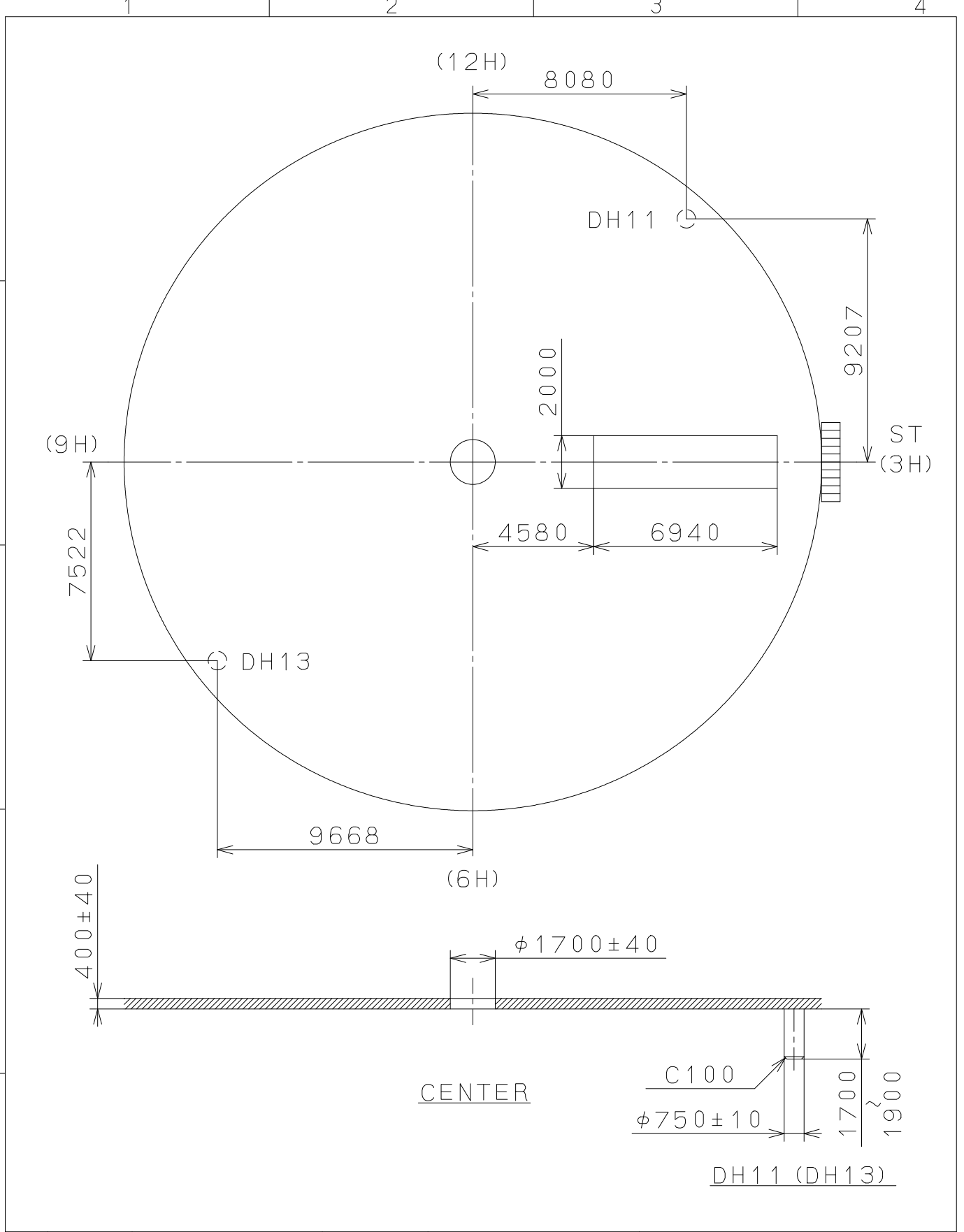

△			Quantity		Cal.NO.:
△			Unit	1 / 1000 mm	GR02-10A
△			Scale	5 : 1	Parts No.:
△			Date		
△			Drawn		
Mark	Date	Description	Appr.	Checked	Name:
		Alterations	Approved	D. Yamada	
Material					Indications for Dial
Heat Treatment					Drawing No.: GR02DOCS
Hardness					MIYOTA
Plating					

This drawing is provisional and subject to our reconfirmation and/or revision without notice.

TIPW 065-543 (01) *** (2100 1121) 03-05-07

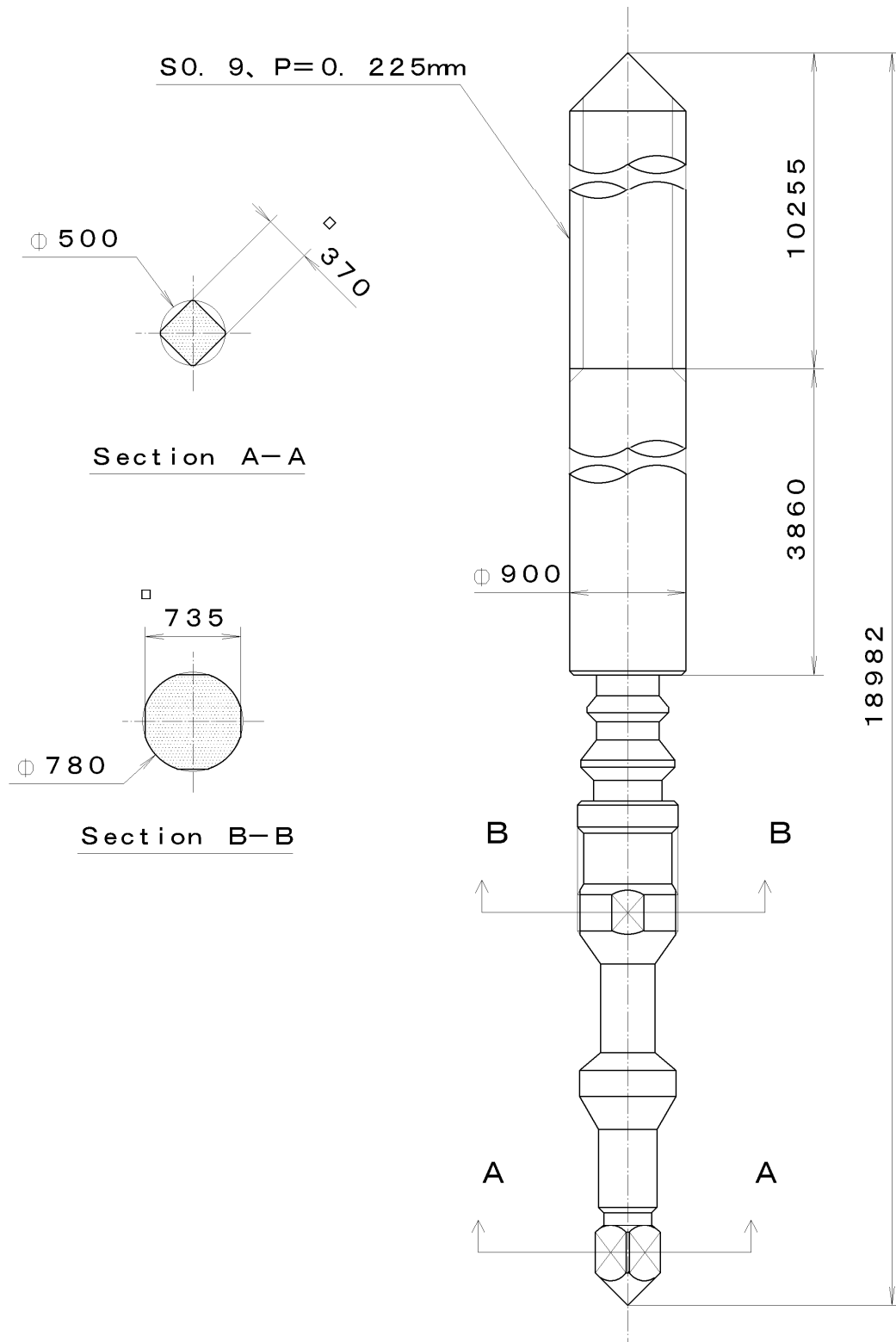

△		Quantity		Cal. No. :	
△		Unit	1/1000 mm	Parts :	
△		Scale	20:1	065-543	Name : SETTING STEM
△		Date			
△		Drawn			
△		Checked	T. Hiruta		
△		Approved			
Material					
Heat Treatment		General Tolerances		CITIZEN WATCH CO., LTD. TOKYO, JAPAN	
Hardness		Dimensions			
Plating		Angles			