

Watch Movement Specification and Drawing

Sweep Second Multi-Eye

VH67A

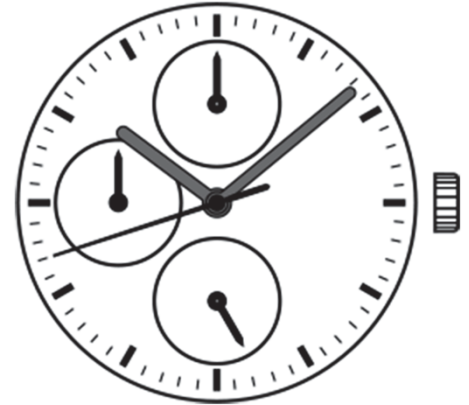

Movement Size: **10 1/2"**
 Diameter: **Φ23.70mm**
 Height: **3.45mm**

Items	Ver.	Items	Ver.
Specification	1		
Appearance	1		
Casing	1		
Hand Fitting	1		
Hand Setting Stem	1		
Dial	1		
Casing Ring	1		
Assembly Plan	1		
Hands (For TYPE S)	1		
Hands (For TYPE M / L)	1		

CAL.VH67A 10½ Ligne Quartz Movement

Three Hands (1/4 Center Second Hand) with 3 eyes Small 24 Hour Indicator, Date & Day Hands

1. FUNCTION

- Jewel 2 jewels
- Accuracy Less than ± 15 seconds / month (Normal temperature range)
- Battery life Approx. 2 years
- Regulation hands unbalance
 - Hour hand : Less than $0.50 \mu\text{N}\cdot\text{m}$ (50 mg·mm)
 - Minute hand : Less than $0.80 \mu\text{N}\cdot\text{m}$ (80 mg·mm)
 - Second hand : Less than $0.30 \mu\text{N}\cdot\text{m}$ (30 mg·mm)
 - Small hands : Less than $0.10 \mu\text{N}\cdot\text{m}$ (10 mg·mm)
(Date, day & 24 hour indicator hands)
- Additional function
 - Date & Day display with quick date correction
 - 24 hour indicator (Synchronized regular hour hand)

2. USE AND TEST CONDITION

- Battery SR920SW (Recommended battery is SEIZAIKEN)
- Operation temperature range From $- 5 \text{ }^{\circ}\text{C}$ to $+ 50 \text{ }^{\circ}\text{C}$
- Antimagnetic $\geq 1600 \text{ A / m}$ (Direct current magnetic field)
- Test of accuracy 10 seconds (Duration of measurement)

*** All specifications are subject to change without notice.**

Appearance

VH67A

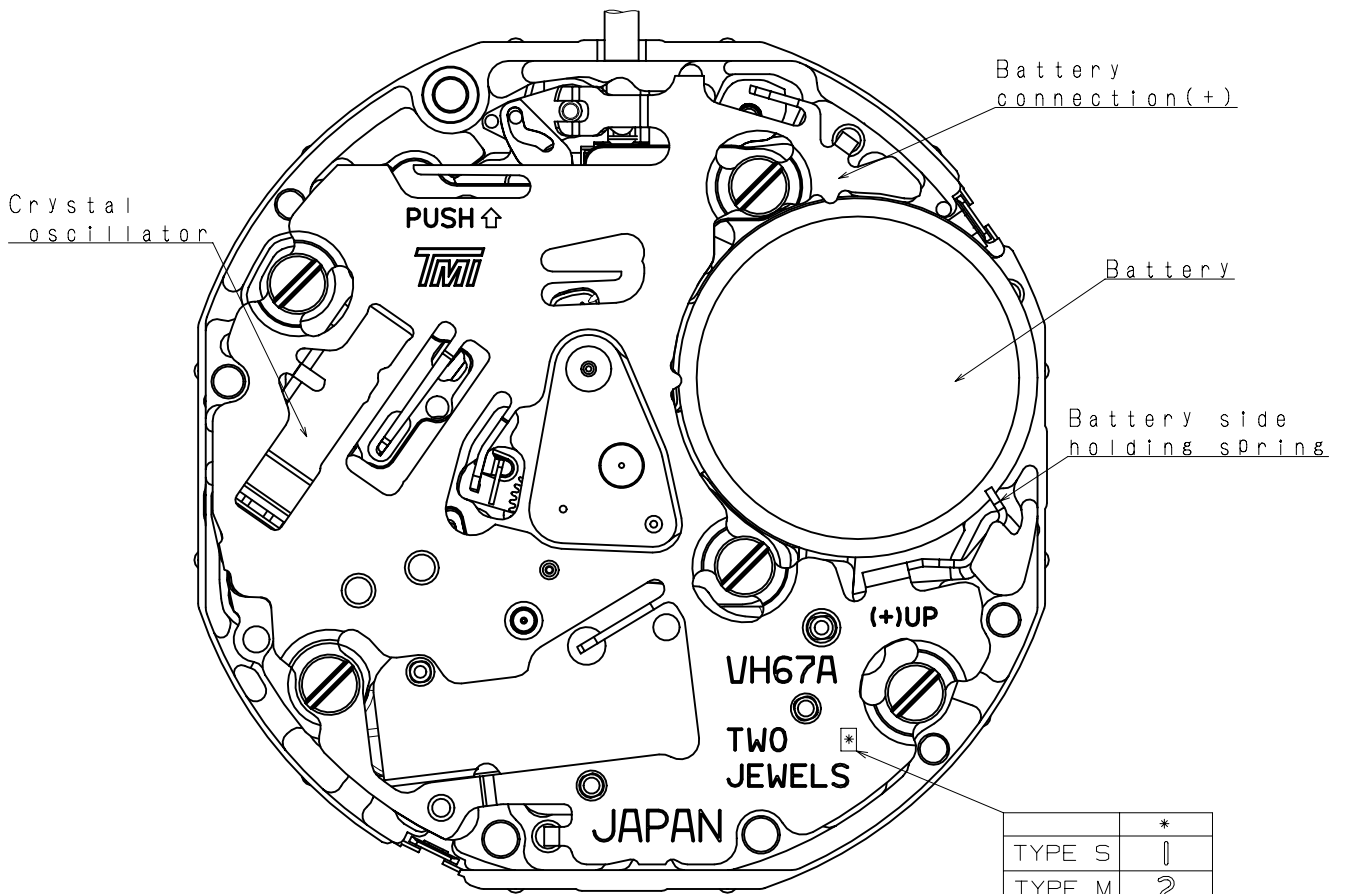

	*
TYPE S	1
TYPE M	2
TYPE L	3

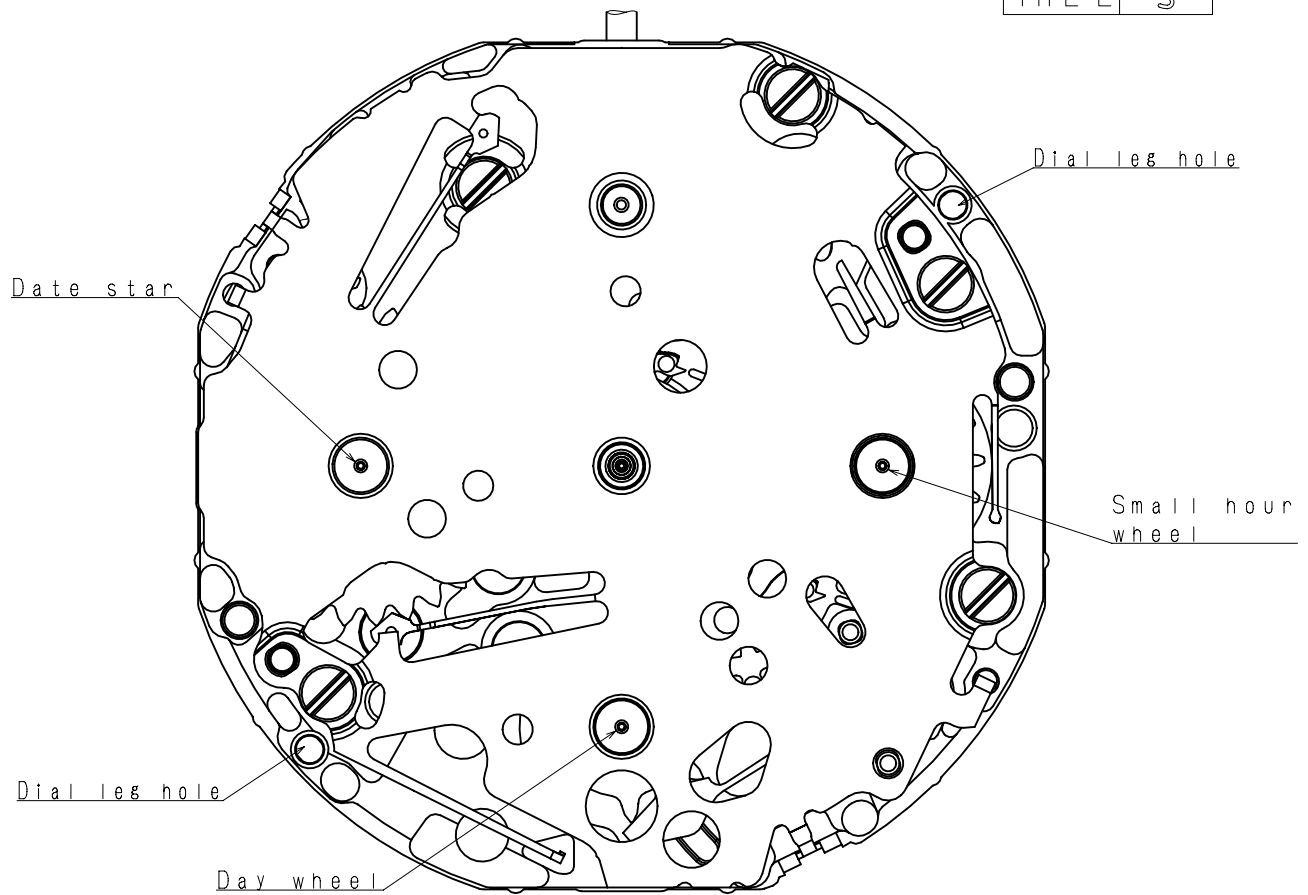

Version : 1

* First pull out stroke 45
 ** Second pull out stroke 39.8

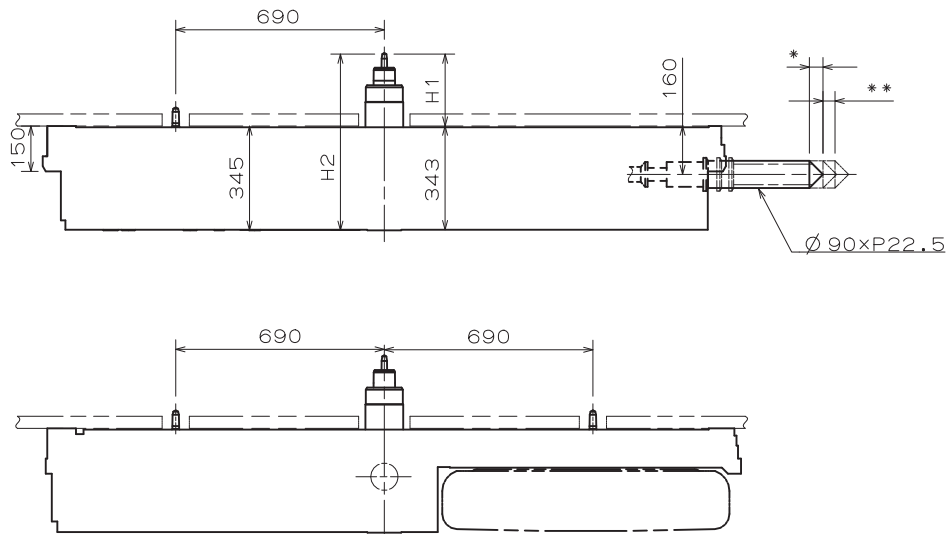

Center post 中心柱位		TYPE S	TYPE M	TYPE L	Hand Setting Stem	TYPE A	TYPE B
		低針	一般針高	高針			
Maximum height from main plate surface 與機芯平面的最大高度	H1	185	238	293	L1	2436	3012
Total height incl. movement 機芯總高度	H2	530	583	638			

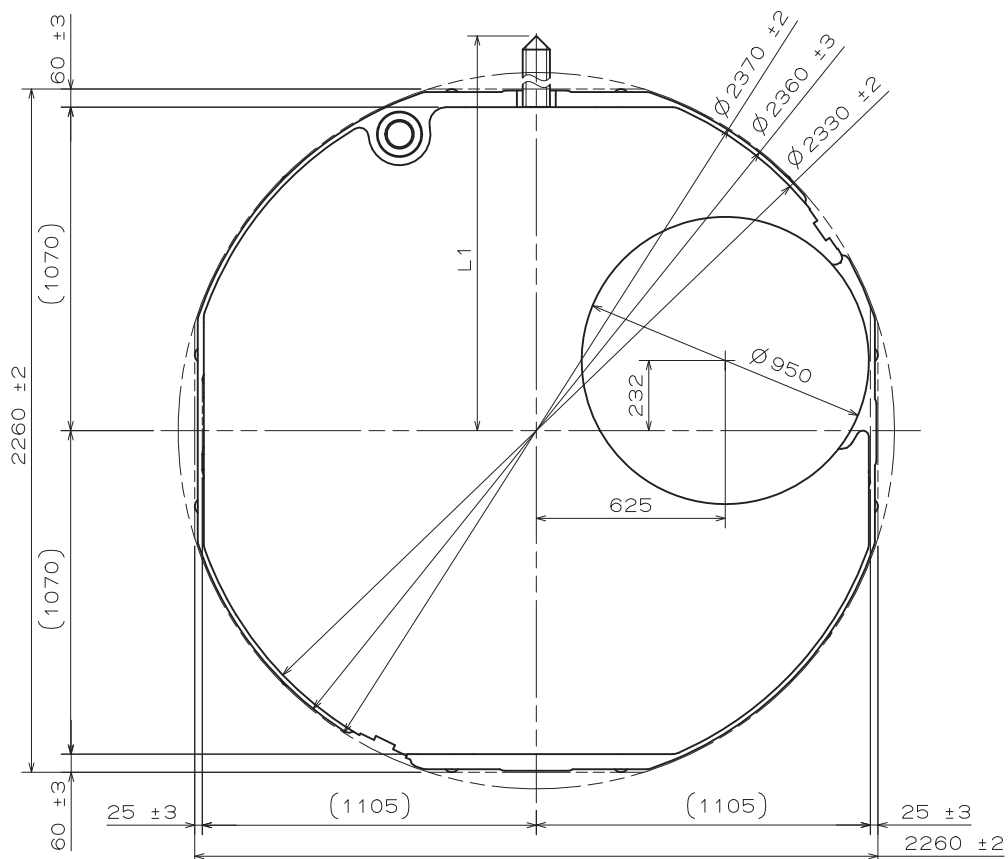

- * Hour hand unbalance $\leq 0.5 \mu\text{N}\cdot\text{m}$ (50mg·mm)
- * Minute hand unbalance $\leq 0.8 \mu\text{N}\cdot\text{m}$ (80mg·mm)
- * Second hand unbalance $\leq 0.3 \mu\text{N}\cdot\text{m}$ (30mg·mm)
- * Small hour hand unbalance $\leq 0.1 \mu\text{N}\cdot\text{m}$ (10mg·mm)
- * Date hand unbalance $\leq 0.1 \mu\text{N}\cdot\text{m}$ (10mg·mm)
- * Day hand unbalance $\leq 0.1 \mu\text{N}\cdot\text{m}$ (10mg·mm)

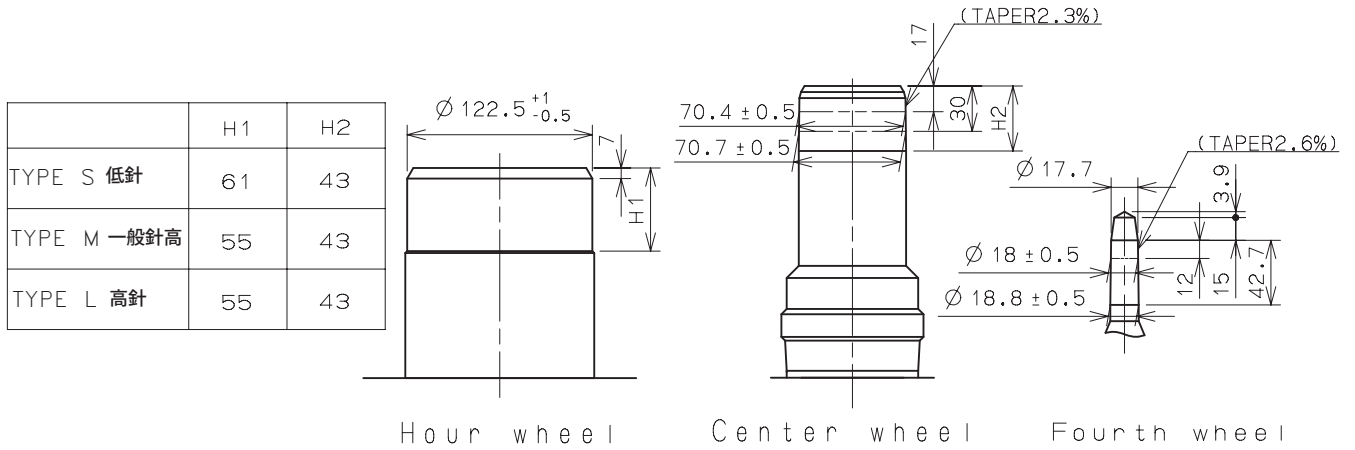

Part name		Part No.		
		TYPE S 低針	TYPE M 一般針高	TYPE L 高針
Hour wheel	時針輪	0273 053	0273 043	0273 045
Center wheel	分針輪	0221 137	0221 089	0221 093
Fourth wheel	秒針輪	0144 014	0144 004	0144 005
Date star	日曆針輪	0970 004	0970 004	0970 005
Small hour wheel	小時針輪	0157 018	0157 018	0157 019
Day wheel	星期針輪	1019 010	1019 010	1019 011

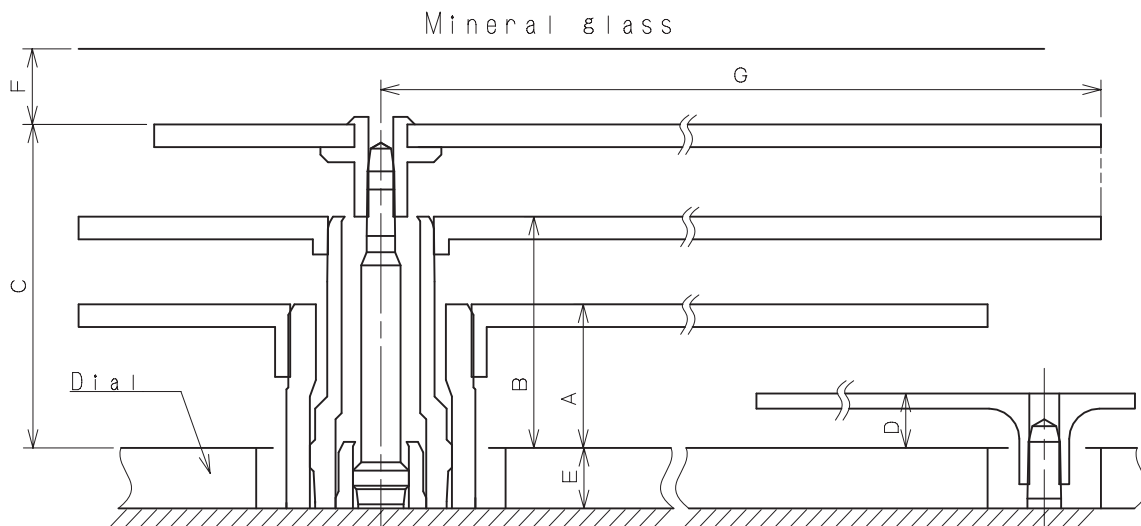
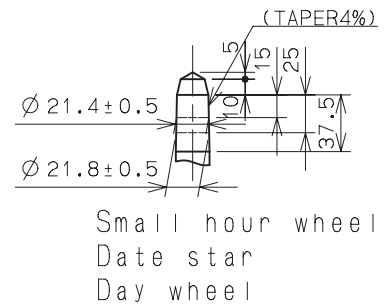

	A	B	C	D	E	F	G
TYPE S 低針	82	118	161	36	40	50	MAX1250
TYPE M 一般針高	95	153	214	36	40	50	-
TYPE L 高針	105	163	224	46	85	50	-

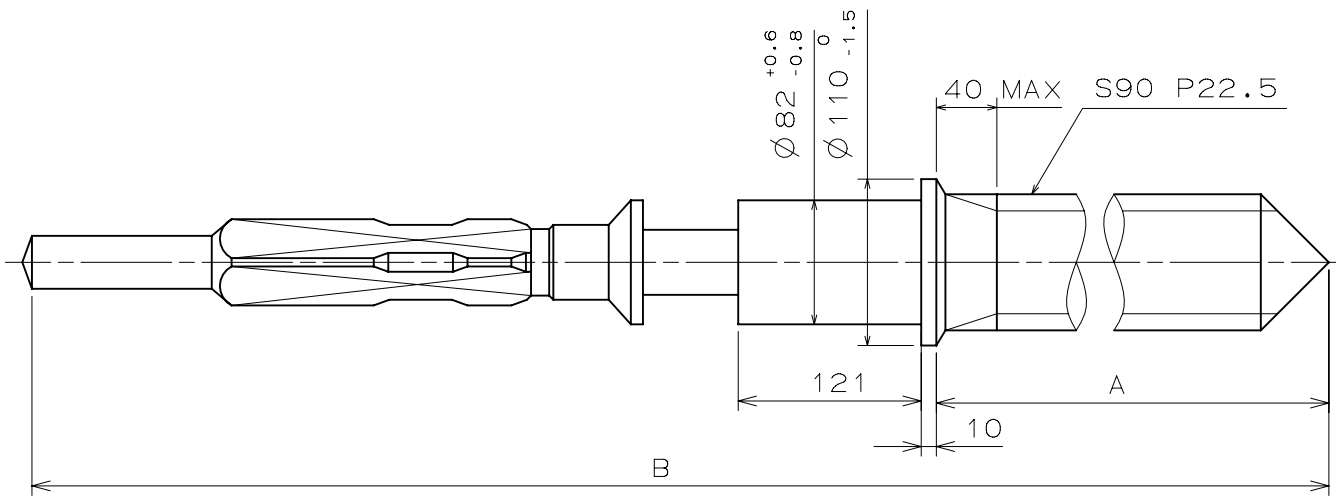

	Part No.	A	B
TYPE A	0351 177	1371	1969
TYPE B	0351 122	1947	2545

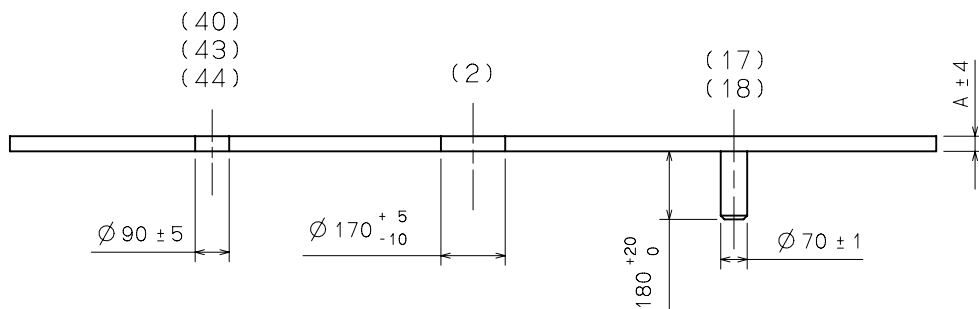
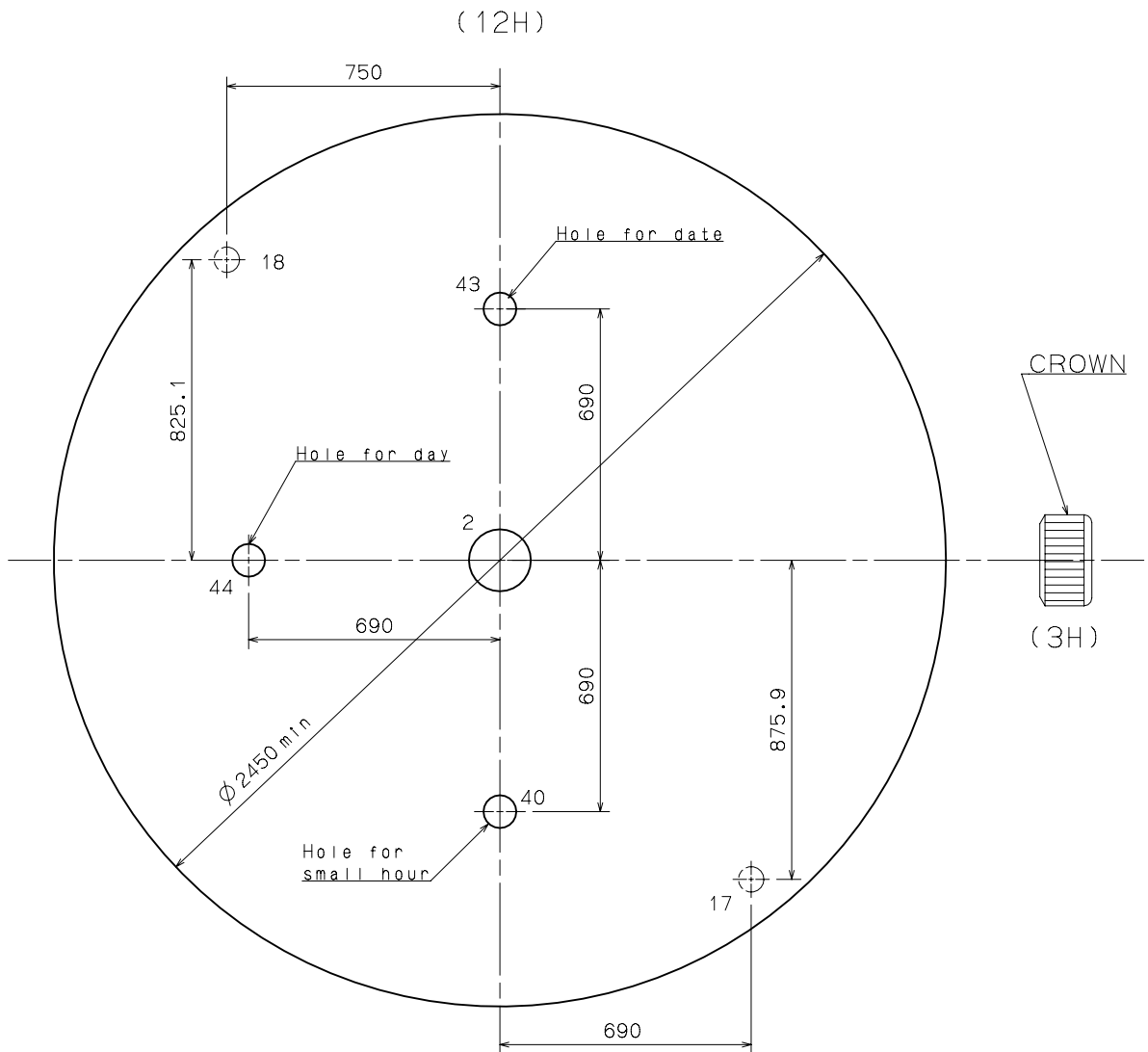

	TYPE S	TYPE M	TYPE L
A	40	40	85

Casing Ring

VH67A

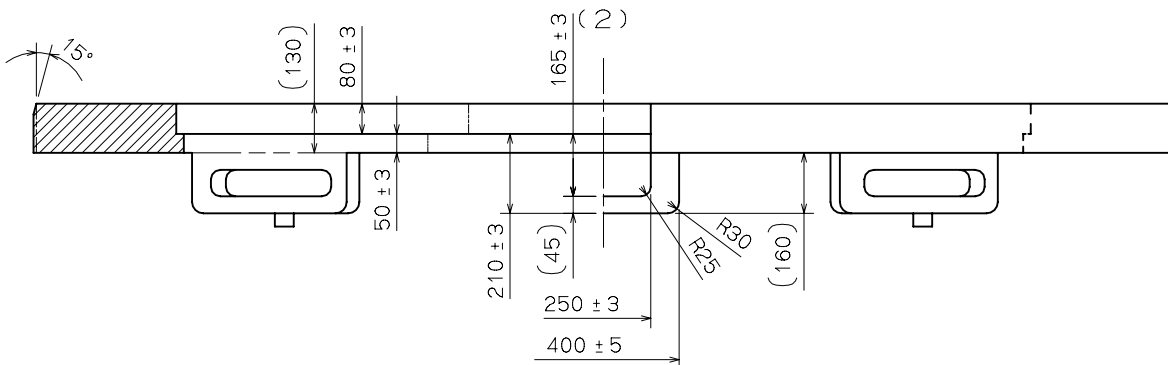
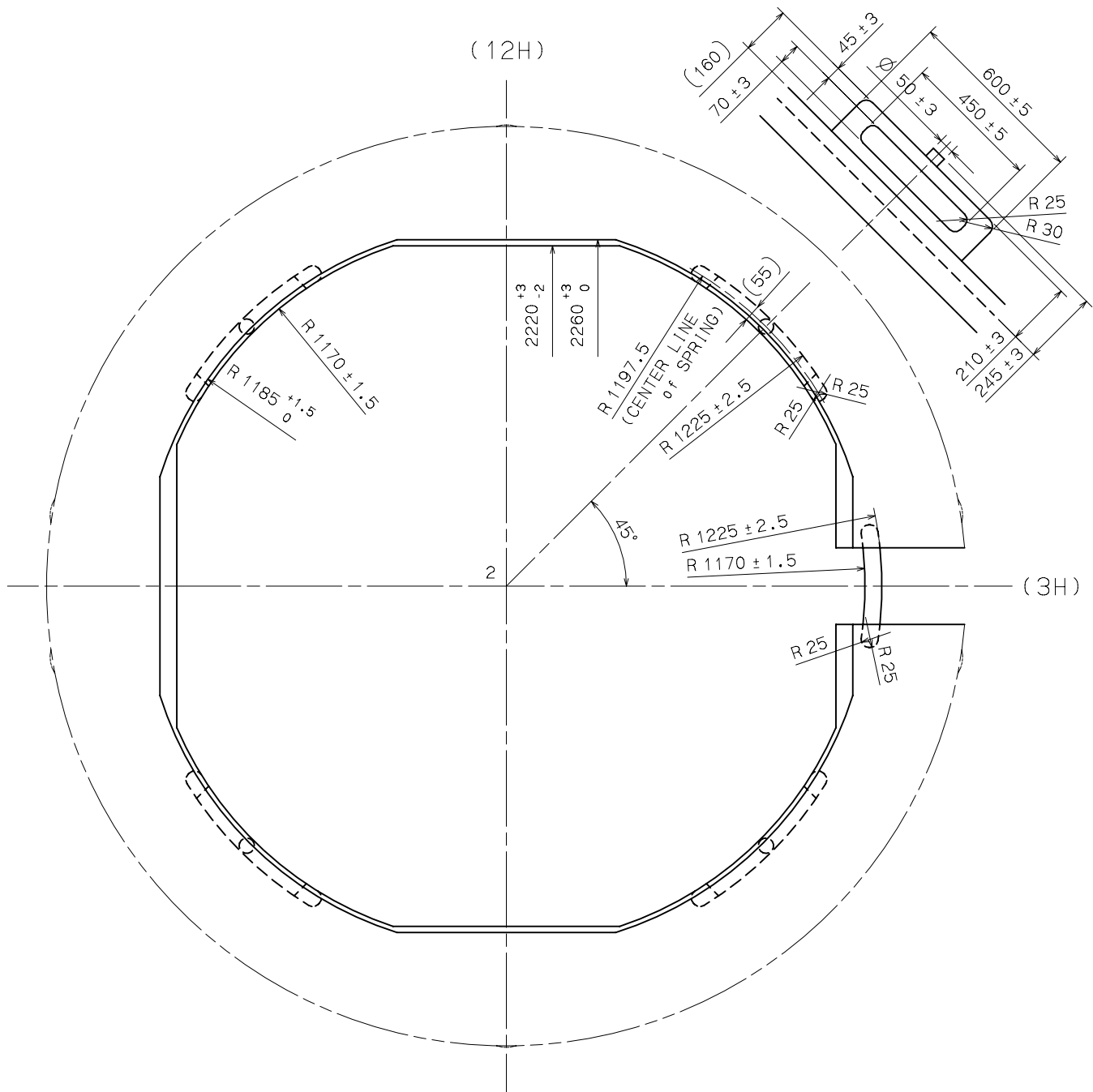

SECTIONAL VIEW of 12H DIRECTION

SIDE VIEW from 3H DIRECTION

Unit : 1=1/100mm

Version : 1

Assembly Plan

VH67A

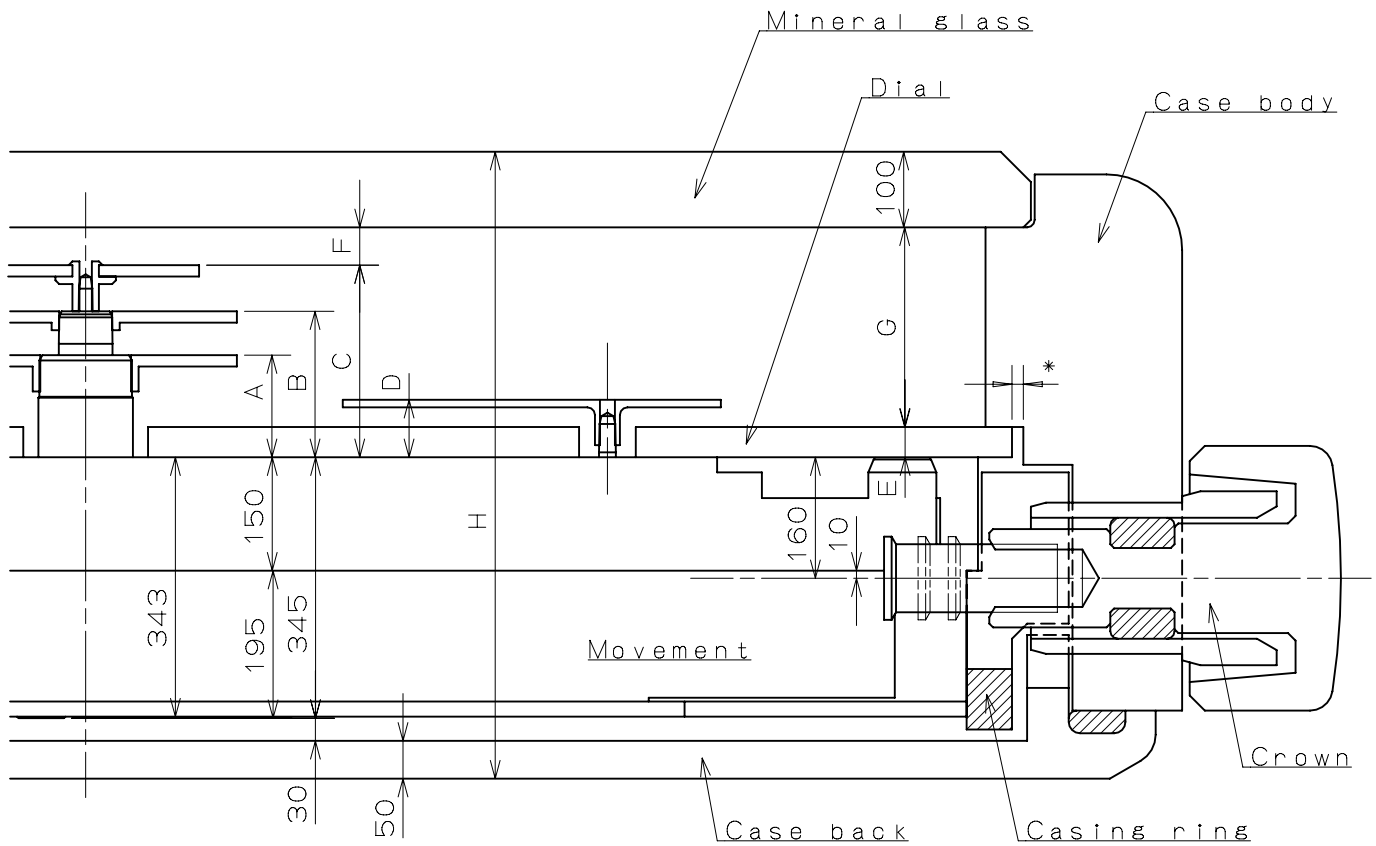

	A	B	C	D	E	F	G	H
TYPE S	122	158	201	76	40	50	211	776
TYPE M	135	193	254	76	40	50	264	829
TYPE L	190	248	309	131	85	50	274	884

*Recommended dimension (Clearance of dial and case body): 15

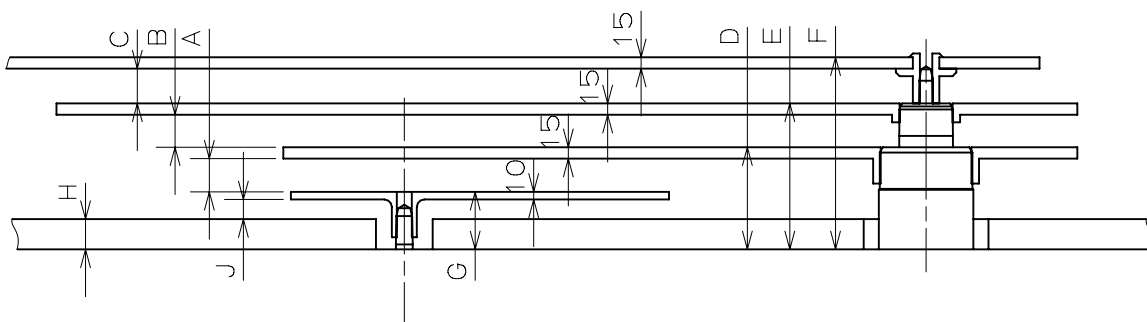

	A	B	C	D	E	F	G	H	J
TYPE S	31	21	28	122	158	201	76	40	26
TYPE M	44	43	46	135	193	254	76	40	26
TYPE L	44	43	46	190	248	309	131	85	36

Unit : 1=1/100mm

Version : 1

SECOND

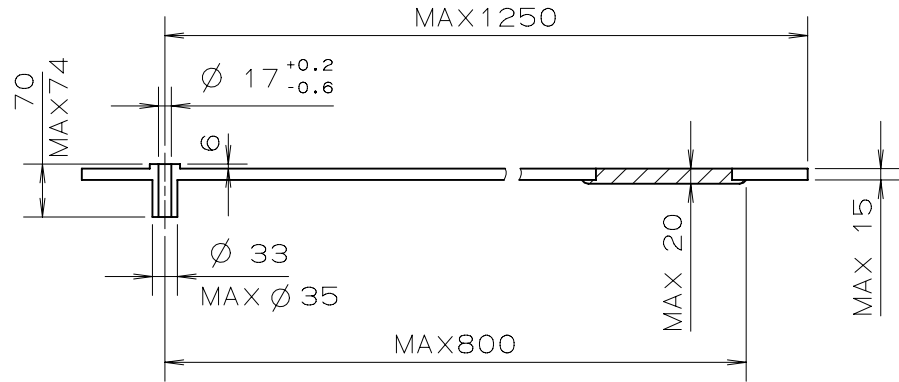

MINUTE

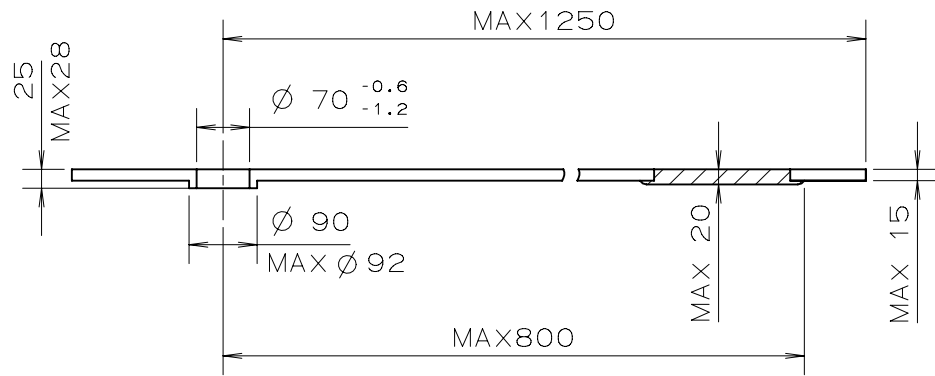

HOUR

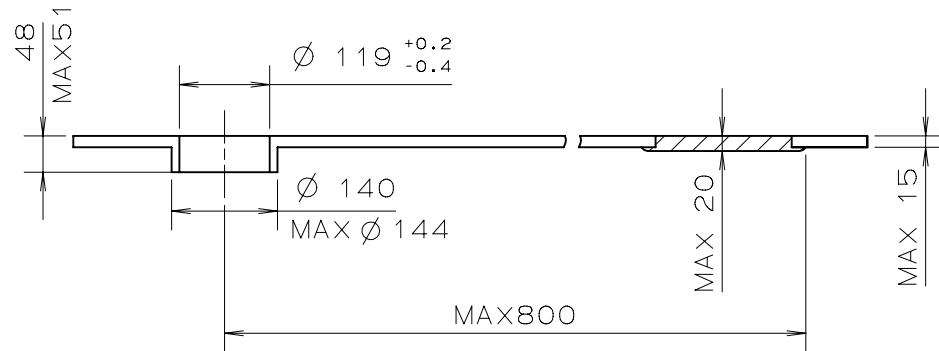

SMALL HOUR

DAY

DATE

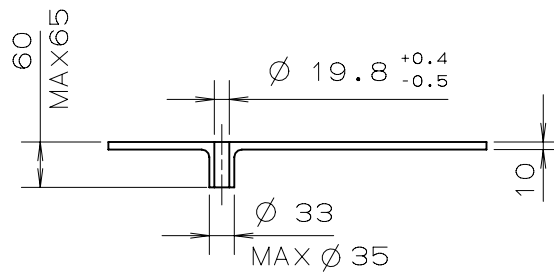

SECOND

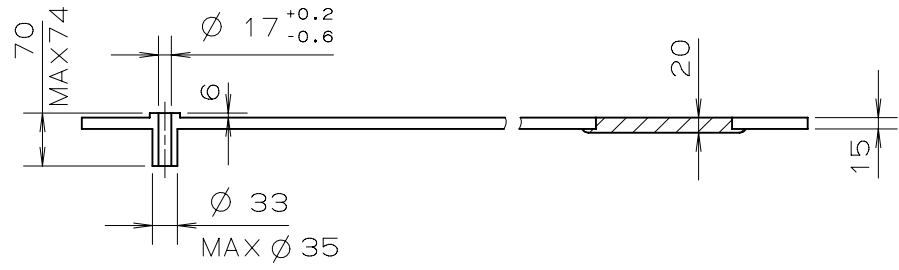

MINUTE

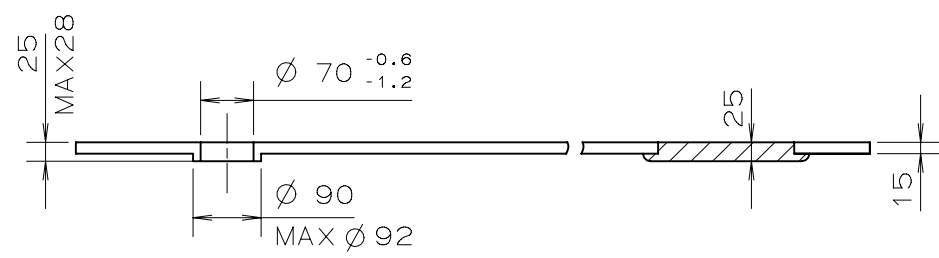

HOUR

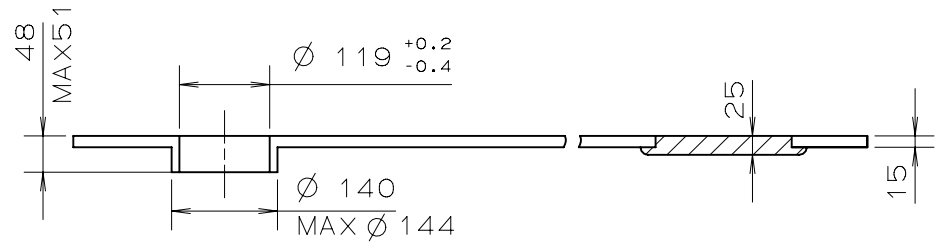

SMALL HOUR
DAY
DATE

