

Watch Movement Specification and Drawing

Standard Movement

PC39A



Movement Size: **10 1/2"**
 Diameter: **Φ23.70mm**
 Height: **4.15mm**

Items	Ver.	Items	Ver.
Specification	1		
Appearance	1		
Casing	1		
Hand Fitting	1		
Hand Setting Stem	1		
Dial - 1	1		
Dial - 2	1		
Casing Ring - 1	1		
Casing Ring - 2	1		
Assembly Plan	1		
Hands	1		

CAL.PC39A 10½ Ligne Quartz Movement

Three Hands with Sun & Moon Disk

1. FUNCTION

- Jewel 0 jewel
- Accuracy Less than ± 30 seconds / month (Normal temperature range)
- Battery life Approx. 3 years
- Regulation hands unbalance
 - Hour hand : Less than $0.30 \mu\text{N}\cdot\text{m}$ (30 mg·mm)
 - Minute hand : Less than $0.30 \mu\text{N}\cdot\text{m}$ (30 mg·mm)
 - Second hand : Less than $0.07 \mu\text{N}\cdot\text{m}$ (7 mg·mm)
- Additional function Sun & Moon display (Synchronized regular hour-hand)

2. USE AND TEST CONDITION

- Battery SR626SW (Recommended battery is SEIZAIKEN)
- Operation temperature range From $-5\text{ }^{\circ}\text{C}$ to $+50\text{ }^{\circ}\text{C}$
- Antimagnetic $\geq 1600\text{ A / m}$ (Direct current magnetic field)
- Test of accuracy 10 seconds (Duration of measurement)

*** All specifications are subject to change without notice.**

Appearance

PC39A

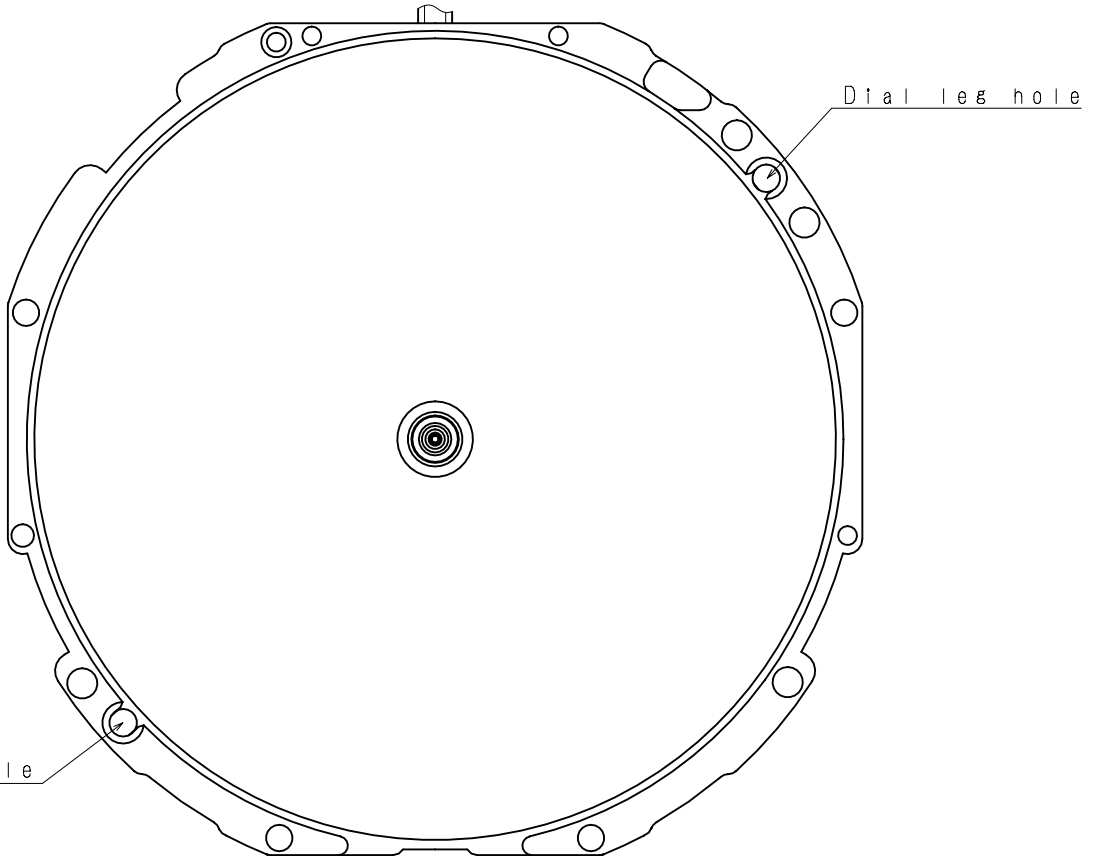
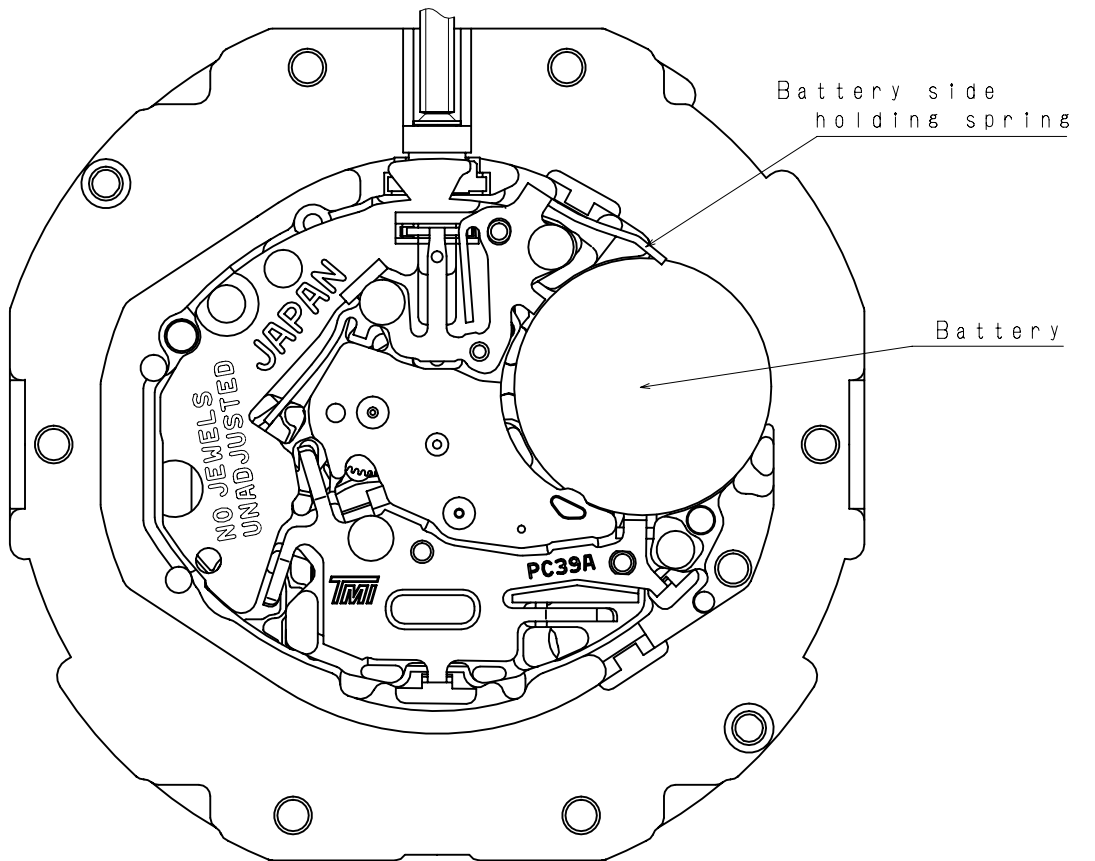

Version : 1

Battery Side Holding spring Type

* First pull out stroke 56

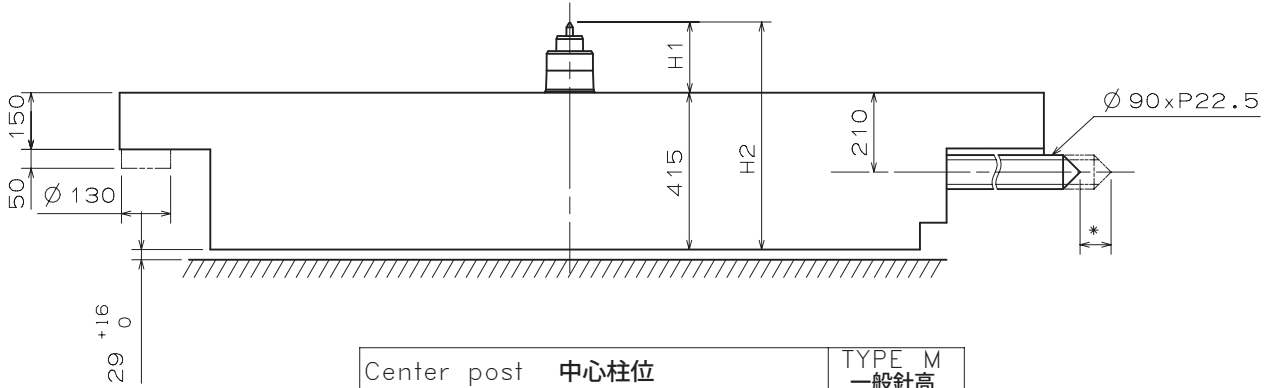

Center post 中心柱位	TYPE M 一般針高
Maximum height from main plate surface 與機芯平面的最大高度	H1 185
Total height incl. movement 機芯總高度	H2 600

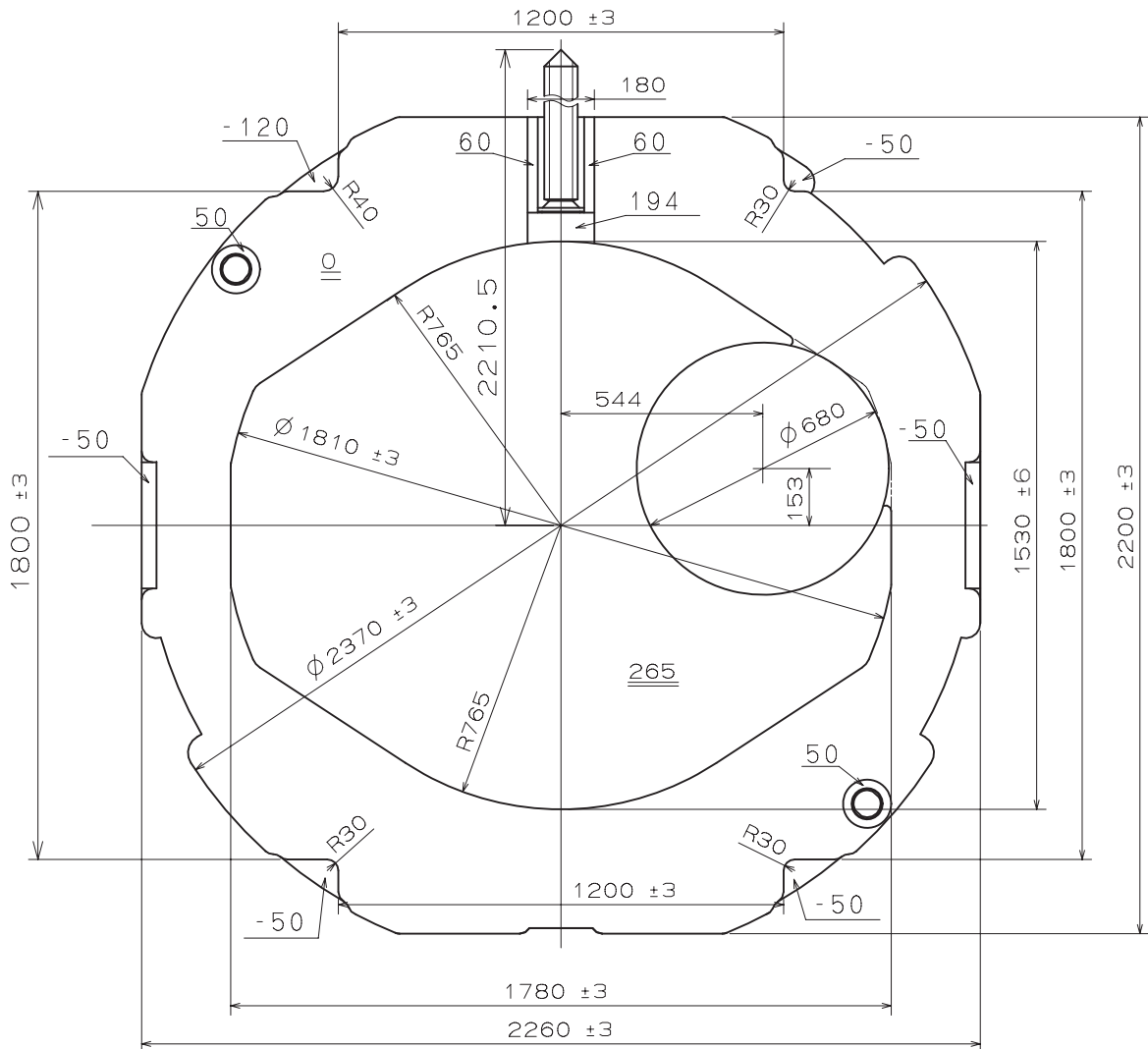

Unit : 1=1/100mm

Version : 1

Hour hand unbalance $\leq 0.3\mu\text{N}\cdot\text{m}$ (30mg·mm)
 Minute hand unbalance $\leq 0.3\mu\text{N}\cdot\text{m}$ (30mg·mm)
 Second hand unbalance $\leq 0.07\mu\text{N}\cdot\text{m}$ (7mg·mm)

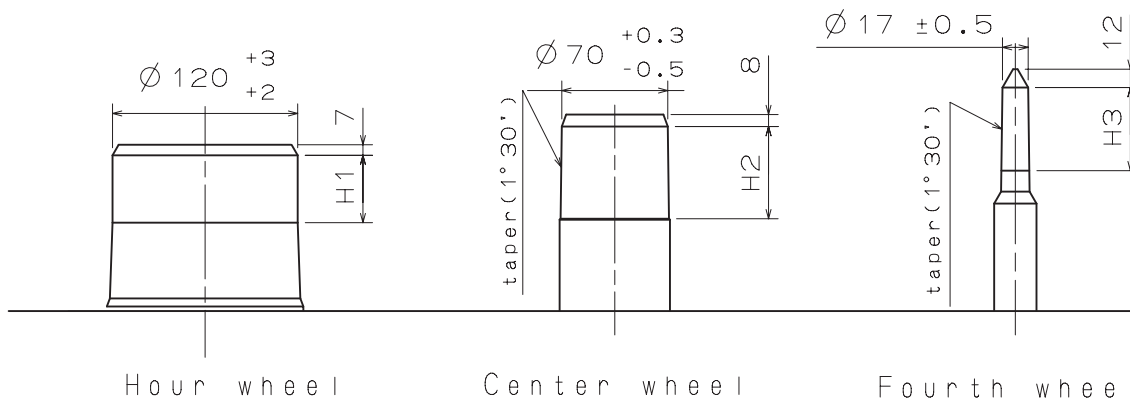

	Part No.			Dimension		
	Hour wheel 時針輪	Center wheel 分針輪	Fourth wheel 秒針輪	H1	H2	H3
TYPE M 一般針高	0271 194	0221 322	0241 310	43	61	55

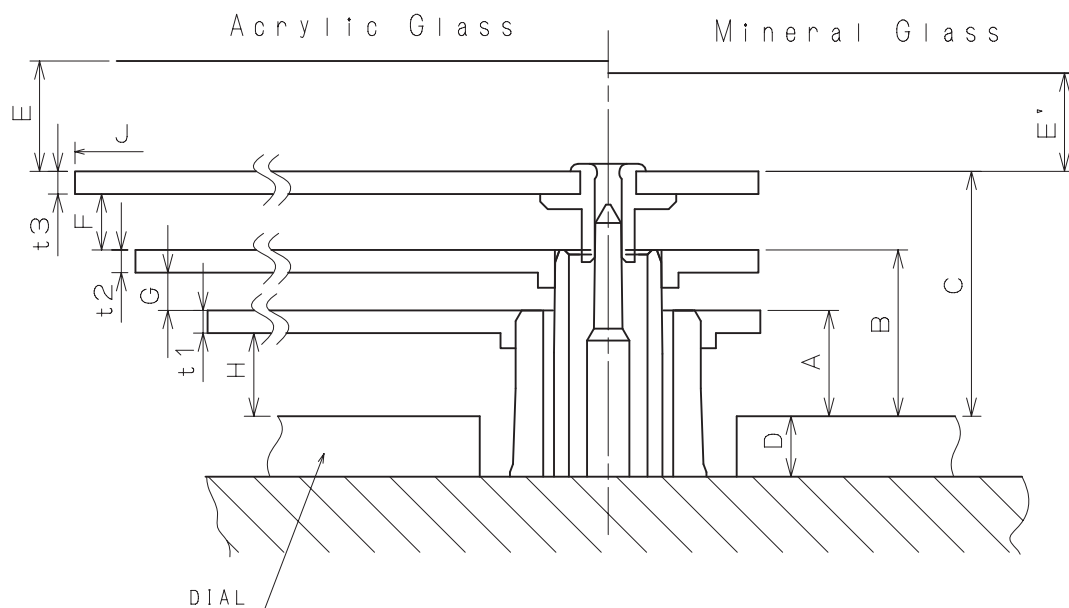

	A	B	C	D	E	E'	F	G	H	t1	t2	t3
TYPE M 一般針高	70	110	162	40	*	*	37	25	55	15	15	15

*	J		
	Max 800	800~850	850~
E'	Min 40	Min 45	Min 65
E	Min 48	Min 53	Min 73

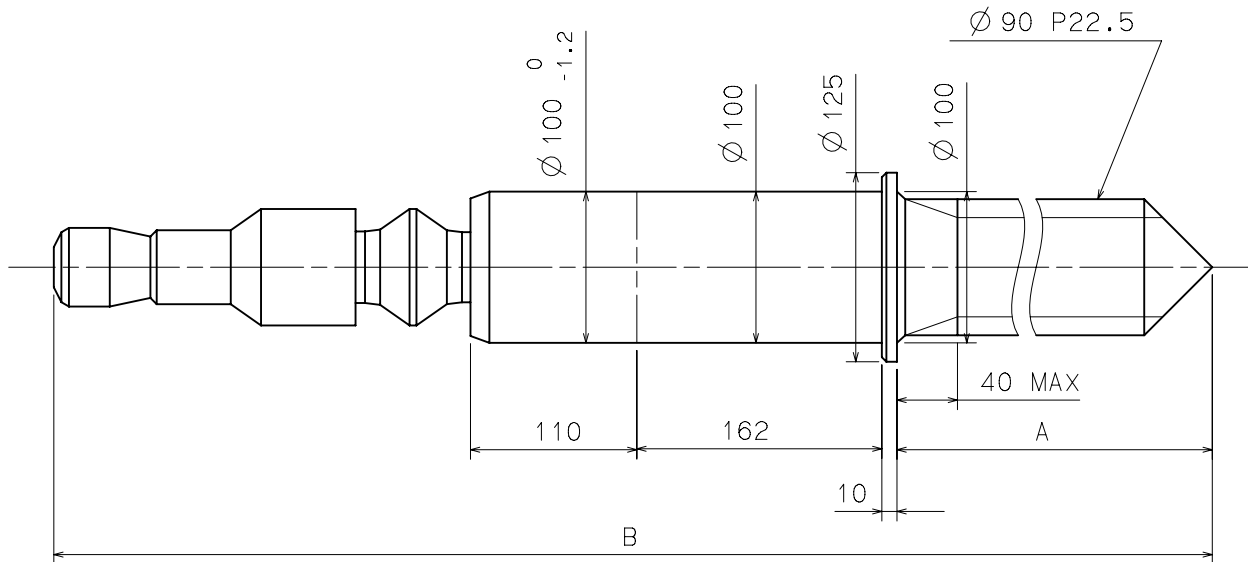

	Part No.	A	B
TYPE A	0354 194	1355	1912.5

Do not lubricate the hand setting stem.

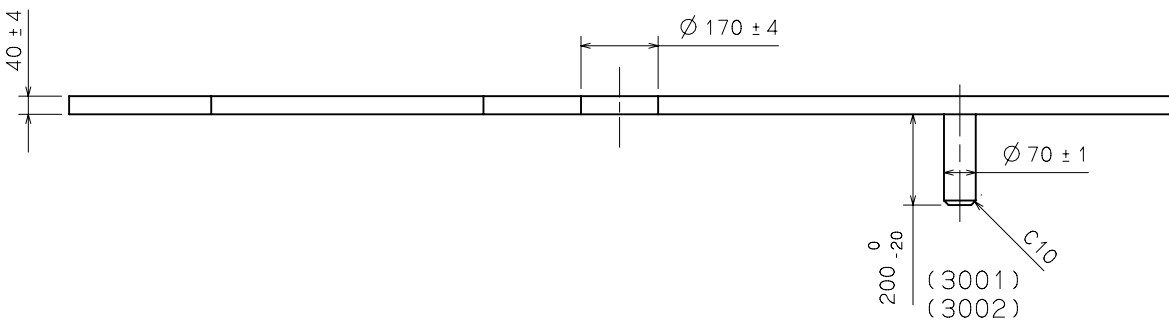
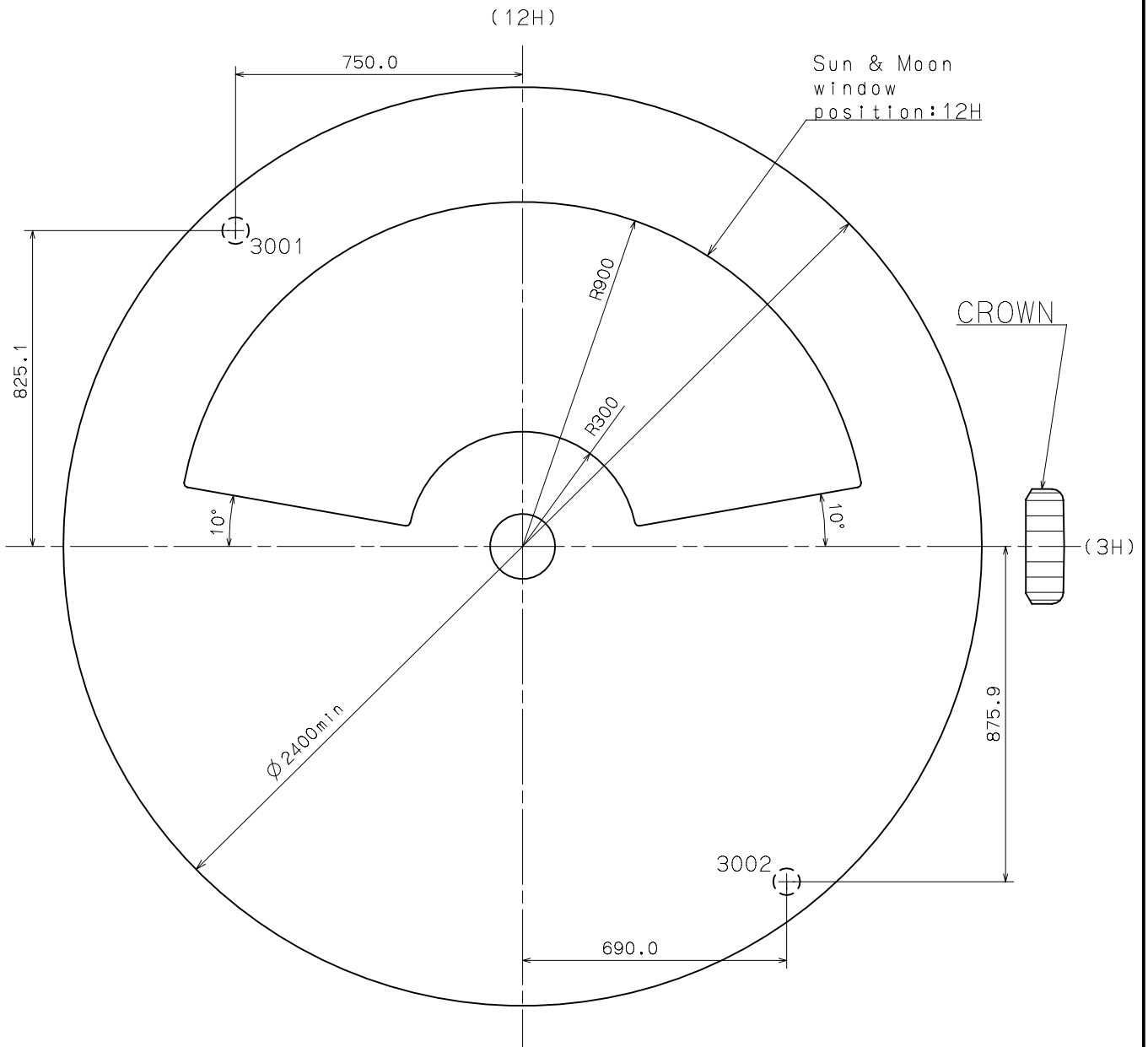

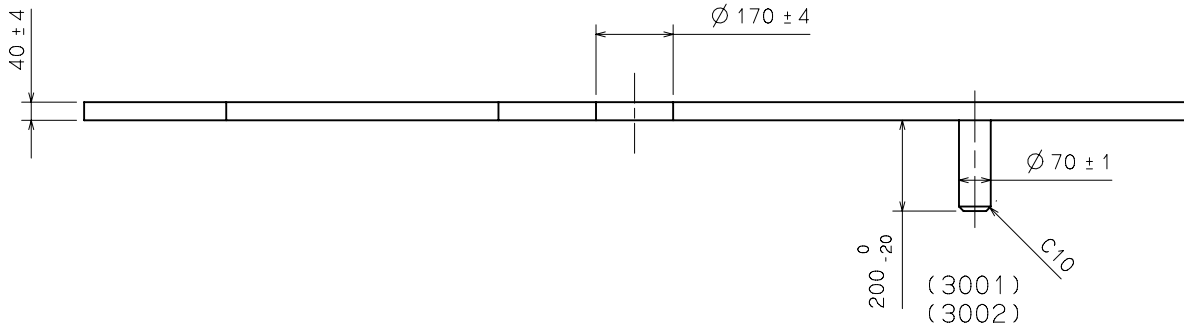
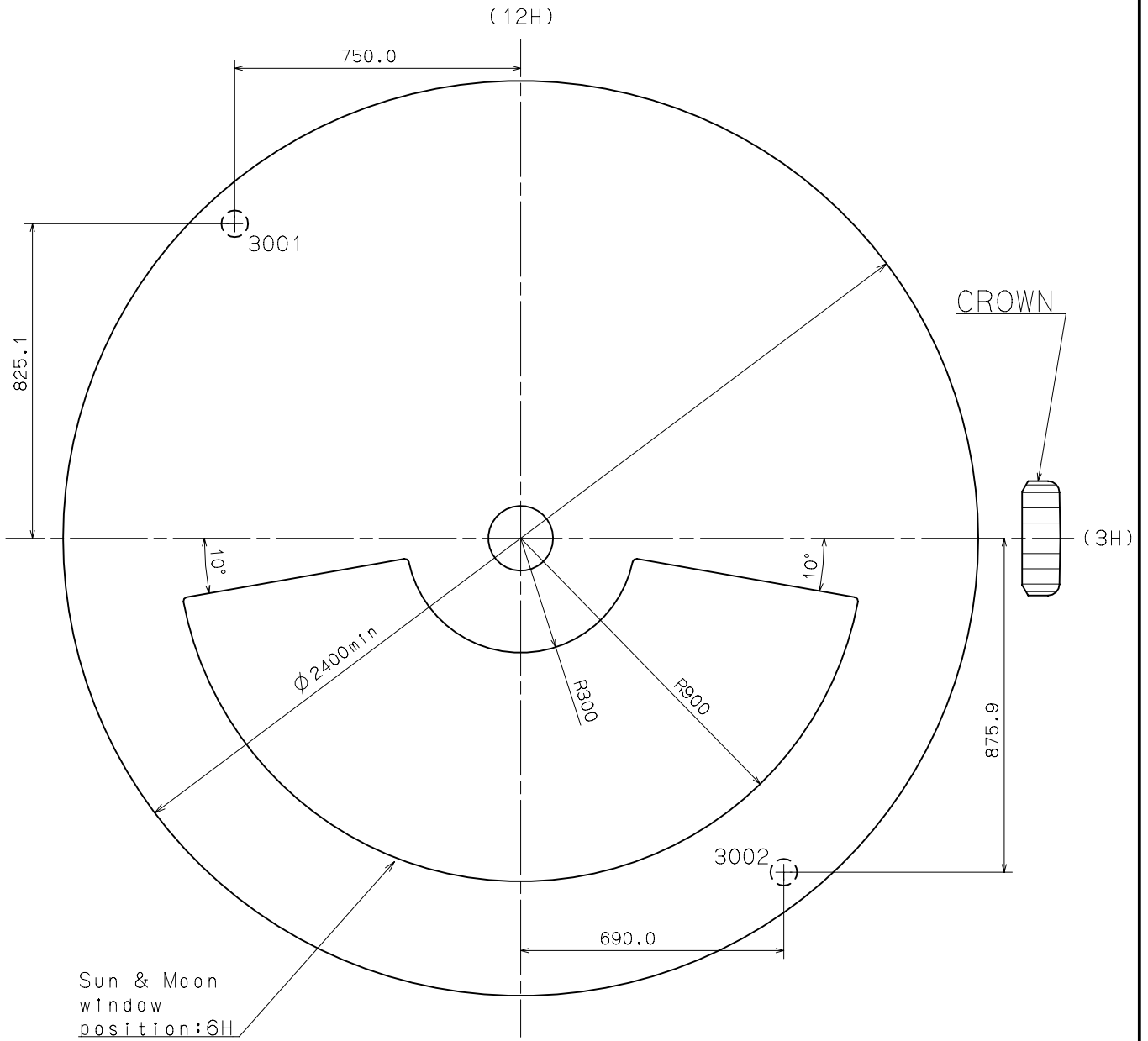

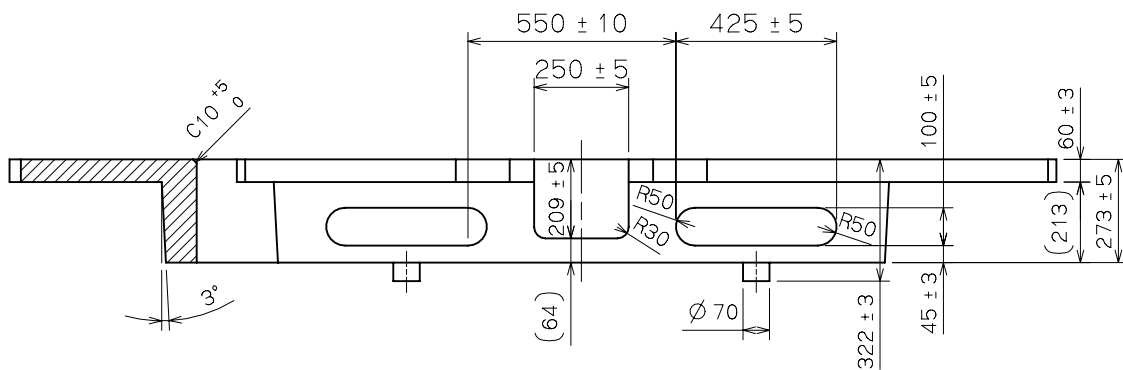
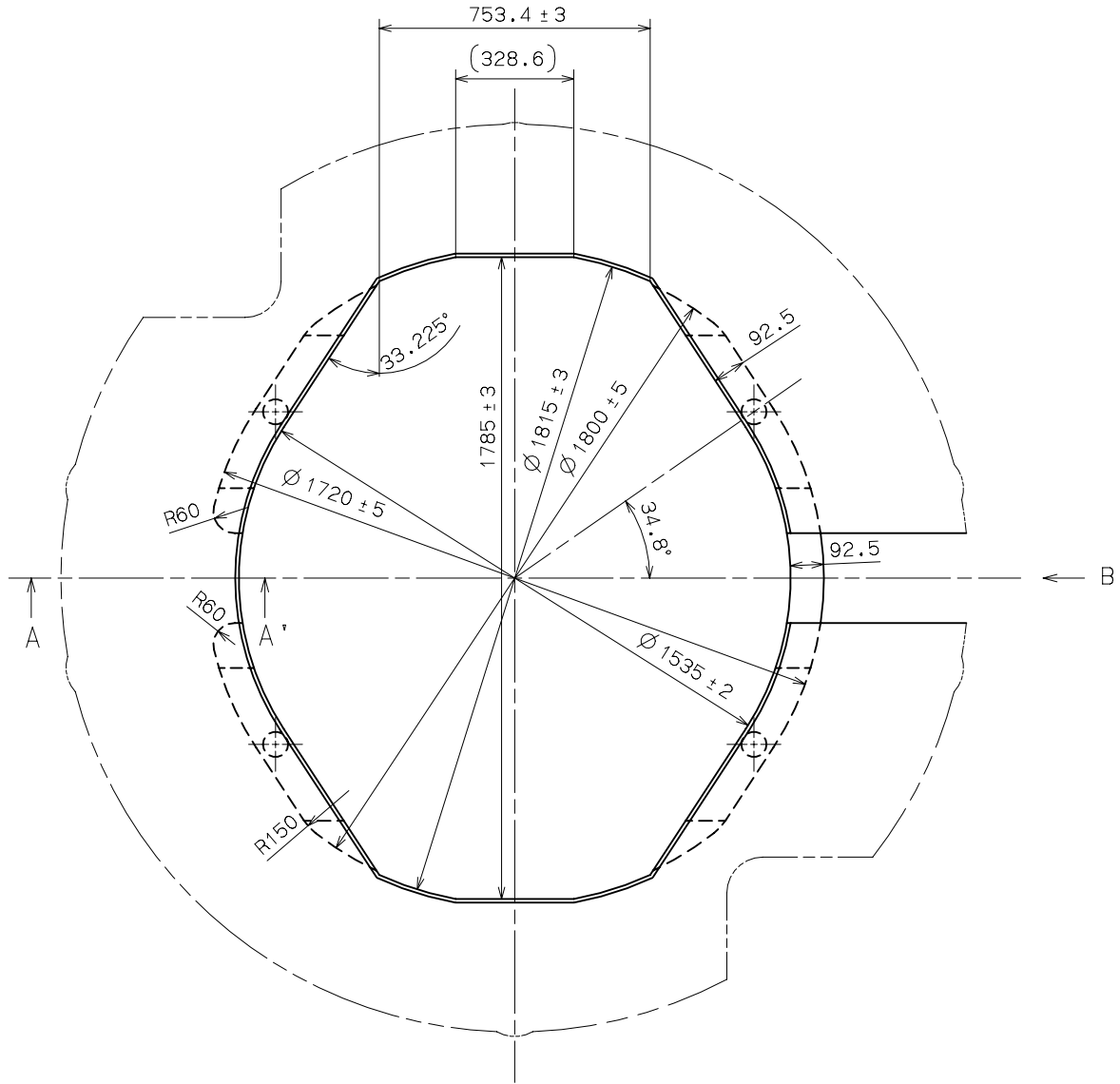

SECTIONAL VIEW of A-A'

SIDE VIEW from B DIRECTION

Unit : 1=1/100mm

Version : 1

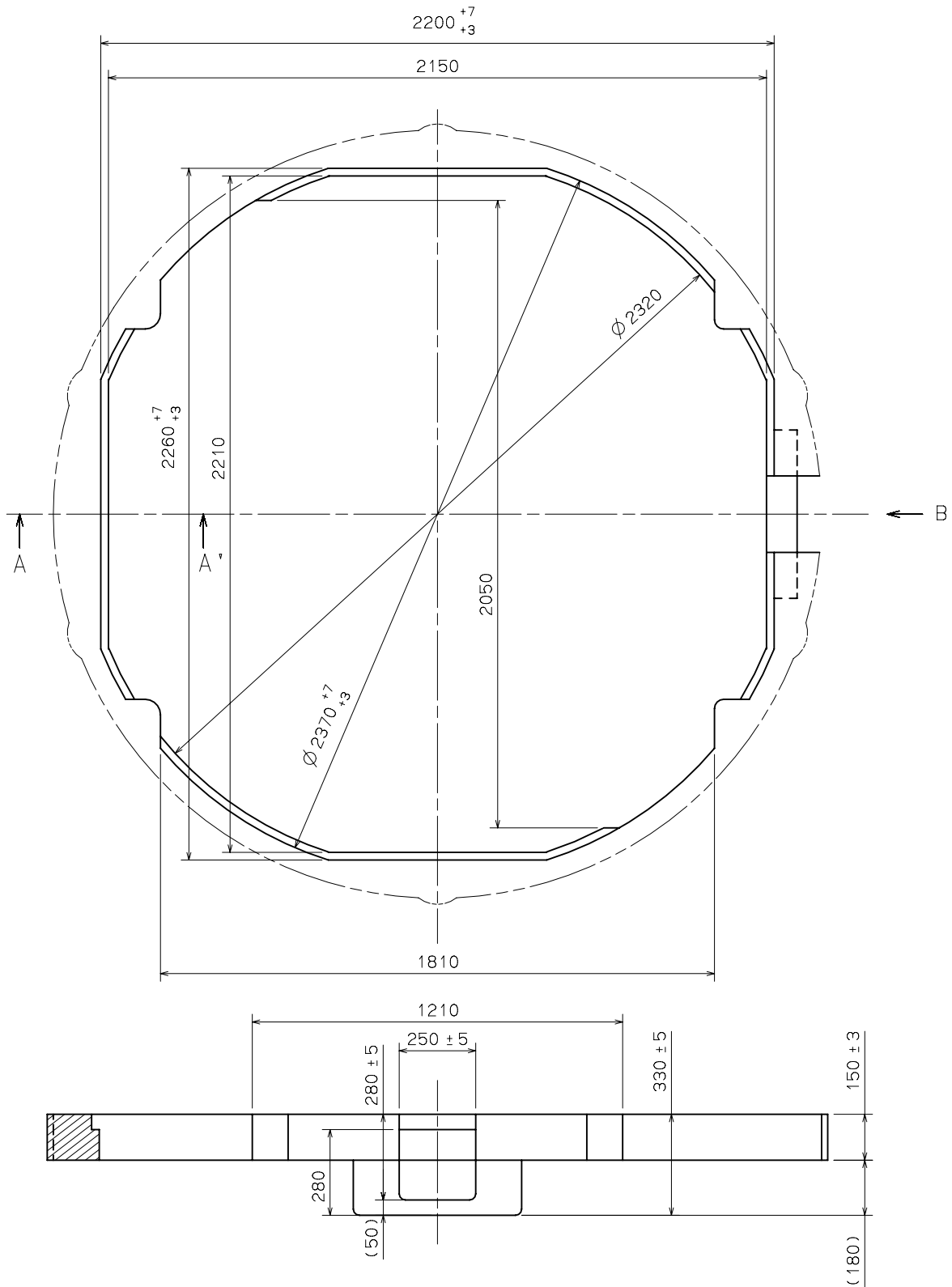

SECTIONAL VIEW of A-A'

SIDE VIEW from B DIRECTION

Unit : 1=1/100mm

Version : 1

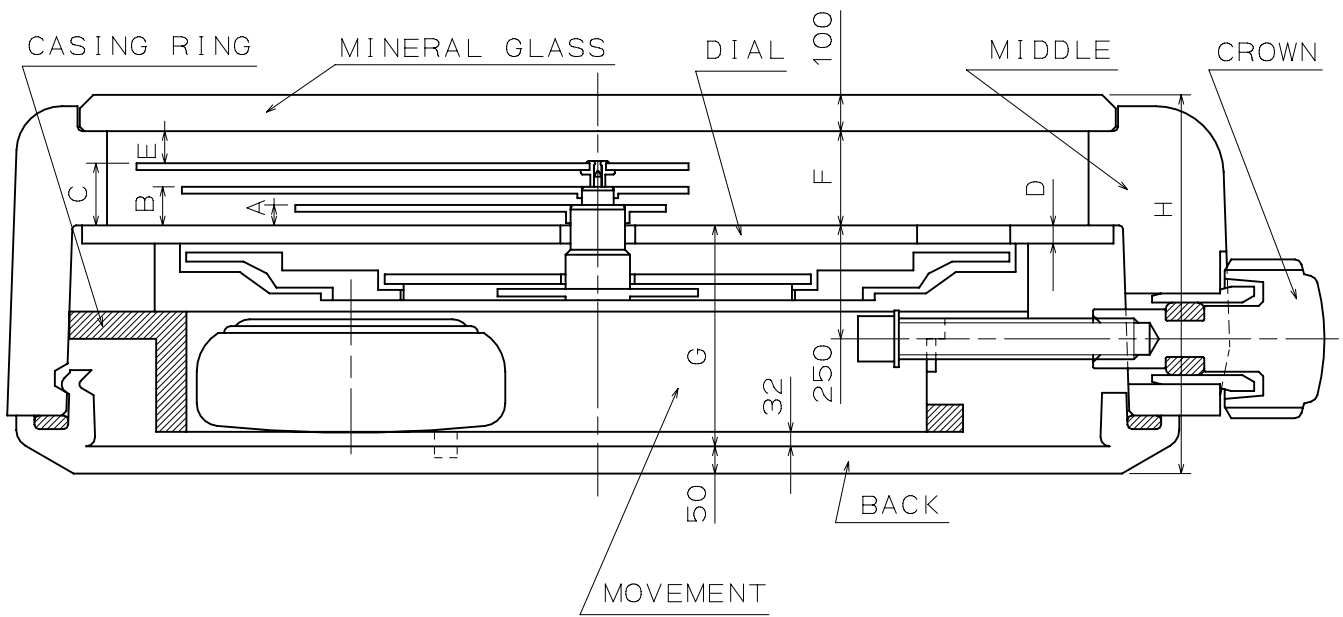

	A	B	C	D	E	F	G	H
TYPE M	70	110	162	40	65	227	487	864

SECOND

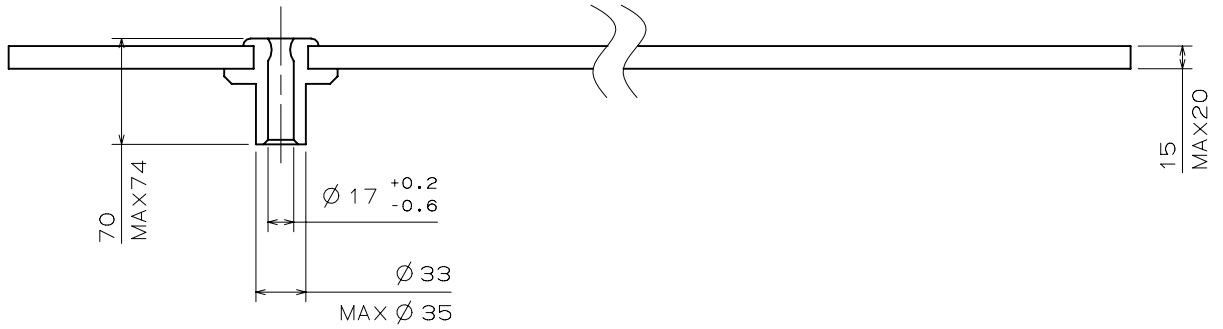

MINUTE

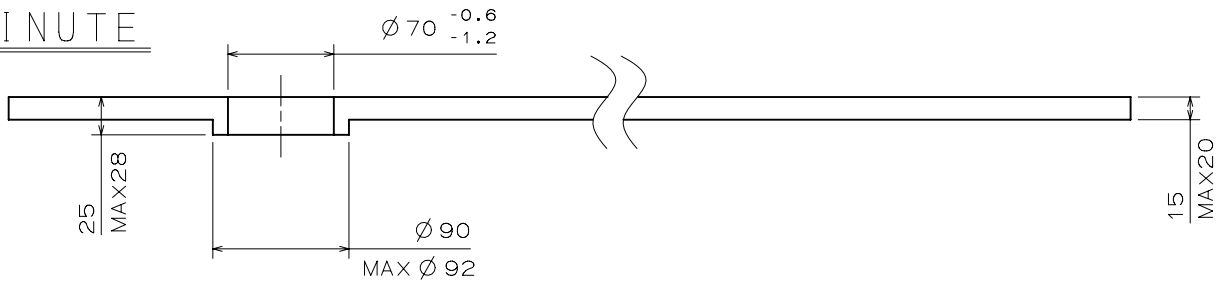

HOUR

