

# RONDA startech 5000

Chronographs, Big Date & Date,  
different calendar systems, Alarm

*Caliber 5051.C – 12½'''*

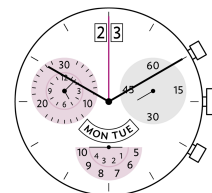

## Product Specifications

Analog quartz movement

Line

startech

Caliber

5051.C

Size

12½'''

Version Swiss Made

13 Jewels / gold plated

Standard battery life

54 months

Hand fitting height

2

## Features

- Very long battery life
- Repairable metal watch movement
- Power saving mechanism with pulled out stem: Reduction of consumption approximately 70%
- Very easy handling by two pushers

**Functions**

- Chronograph
- Center stop second (1/1 sec)
- 1/10 second
- 30 minute / 12 hour counter
- ADD and SPLIT functions
- 3 eyes
- Day indicator
- Big date
- Small second

**Technical Specifications**

Diameter Total	28.60 mm
Case fitting	28.00 mm
Movement height	4.40 mm
Height over standard battery	4.40 mm
Movement rest	0.60 mm
Height over stem	1.90 mm
Length of stem travel	0.90 mm
Stem thread	0.90 mm
Standard battery	395
Standard battery life	54 months
Battery voltage	1.5 V
Current consumption – typical	1.32 µA (Date Mechanism not in Gear)
Current consumption – maximum	1.65 µA (Date Mechanism not in Gear)
Useful torque second – typical	6 µNm
Useful torque minute – typical	300 µNm
Useful torque center stop second – typical	7 µNm
Operating temperature	0 - 50 °C
Instantaneous rate	-10/ +20 sec/month
Resistance to magnetic fields	18.8 Oe
Resistance against shock	NIHS 91-10



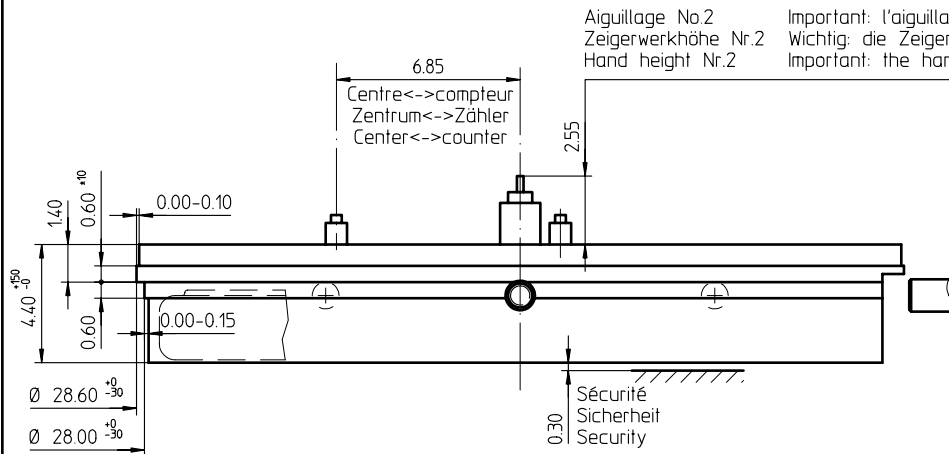

**Côté fond de boîte**  
**Seite Gehäuseboden**  
**Case back side**

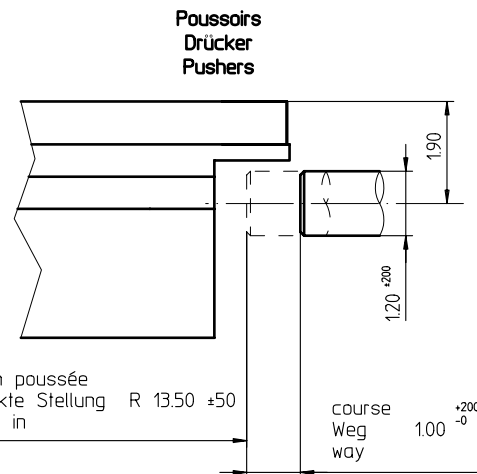

Sécurité entre l'aiguille des secondes et le verre:  
 Sicherheit zwischen Sekundenzeiger und Glas: 0.30mm  
 Security between second hand and glass:

Le cadran doit être tenu par la boîte  
 Das Zifferblatt muss durch die Schale gehalten werden  
 The dial must be hold by the case

La course du poussoir doit être limitée dans le poussoir lui-même. Sa position poussée doit être contrôlée.  
 Die Weglänge des Drückers ist im Drücker selbst zu begrenzen. In der gedrückten Stellung ist seine Position zu kontrollieren  
 The way of the pusher has to be limited in the pusher itself. Its position must be checked while pushed in.

Pile  
 Batterie (395) Ø 9.50 x 2.60mm  
 Battery

Position pour extraire la tige  
 Position zum Entfernen der Stellwelle  
 Position to remove the stem

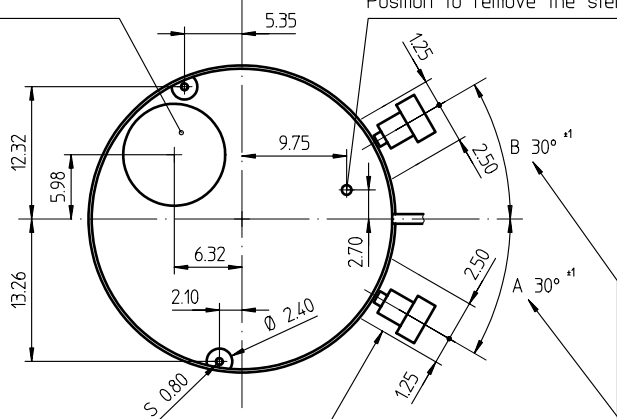

Dégagement cercle d'entourage  
 Freistellung Gehäuseering  
 Opening movement holder

L'angle indiqué pour la direction du poussoir et la position doivent être respectés. Pour un angle de 0° des poussoirs A et B, voir plan 5000.345  
 Der angegebene Winkel für die Drückerrichtung und die Position müssen eingehalten werden. Für einen Drückerwinkel von 0° bei A und B, siehe Zeichnung 5000.345

The indicated angle of the pusher direction and the position must be fulfilled. For pusher angles of 0° (pusher A and B), see drawing 5000.345

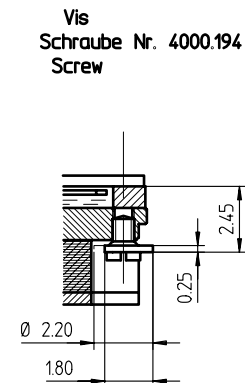
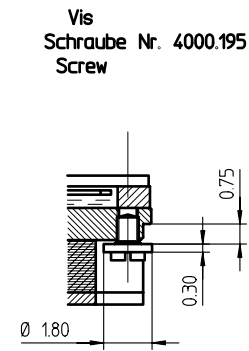
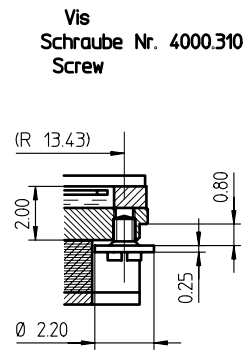
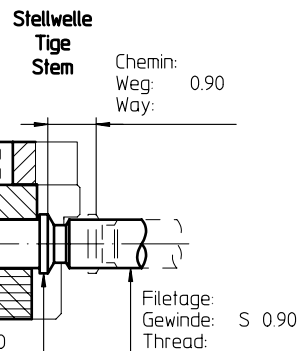

<b>Cage</b> <b>Uhrwerkgestell</b> <b>Frame</b>	<b>12½"</b>	
	<b>RONDA</b>	<b>5050.B, 5050.C, 5051.C</b>
	<b>Issued</b>	14 Nov 2003 mk
	<b>Modified</b>	10. Dez 2007 bk AA 3696
	<b>Released</b>	YES
<b>Tolerance</b>	+/- 20 µm	
<b>Scale</b>	10 : 1 (5 : 1) (A3H)	
Sous réserve de modifications Änderungen vorbehalten Modifications reserved		
<b>No.</b>	5000.319	03

Angle Winkel Angle		30°
Ø Dp	b	
1.00	13.50	
1.10	13.50	
1.20	13.50	
1.30	13.50	
1.40	13.50	

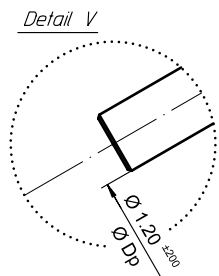
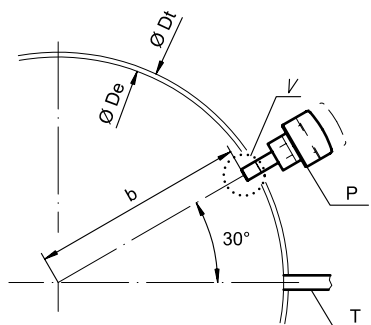

Angle Winkel Angle			0°
Ø Dp	a	b	
1.30	7.40	11.43	
1.40	7.45	11.40	

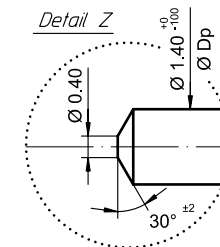
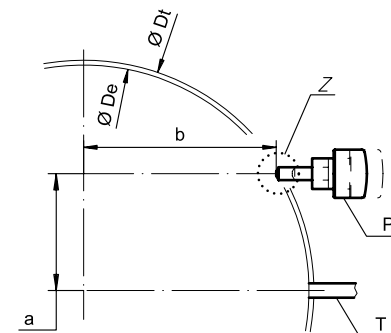

Angle Winkel Angle			20°
Ø Dp	a	b	
1.30	2.57	13.22	
1.40	2.59	13.21	

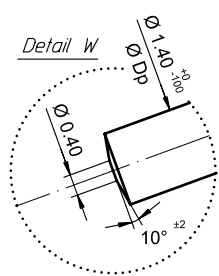
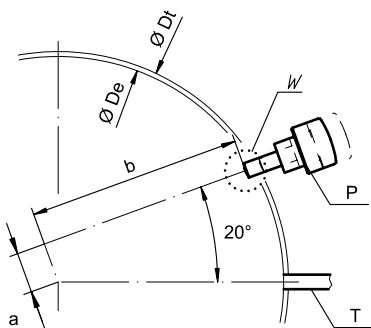

Ø De: diamètre d'encadrement  
Durchmesser der Gehäusepassung  
fitting-diameter

Ø Dp: diamètre du poussoir  
Drückerdurchmesser  
pusher-diameter

Ø Dt: diamètre total  
Totaldurchmesser  
total-diameter

P: poussoir en position poussée  
Drücker in gedrückter Stellung  
pusher in pressed position

T: tige de mise à l'heure  
Stellwelle  
stem

Angle Winkel Angle			15°
Ø Dp	a	b	
1.30	3.83	12.92	
1.40	3.86	12.91	

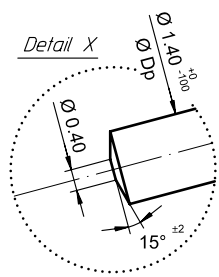
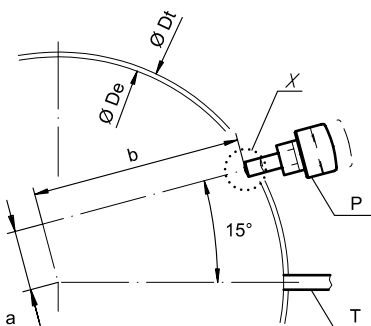

Angle Winkel Angle			10°
Ø Dp	a	b	
1.30	5.06	12.52	
1.40	5.10	12.50	

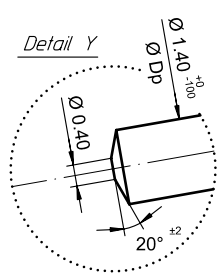
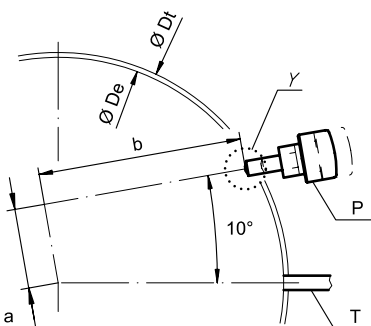

Angle des poussoirs A et B  
Winkel der Drücker A und B  
Angle of pusher A and B

RONDA

4xxx.x, 5xxx.x

Issued	06 Sep 2004	mk
Modified	30. März 2005 ÄÄ 1784	mk
Released	YES	
Tolerance	+/- 20 µm	
Scale	10 : 1 (5 : 1) (A3H)	

Sous réserve de modifications  
Änderungen vorbehalten  
Modifications reserved

No.	5000.345	01
-----	----------	----

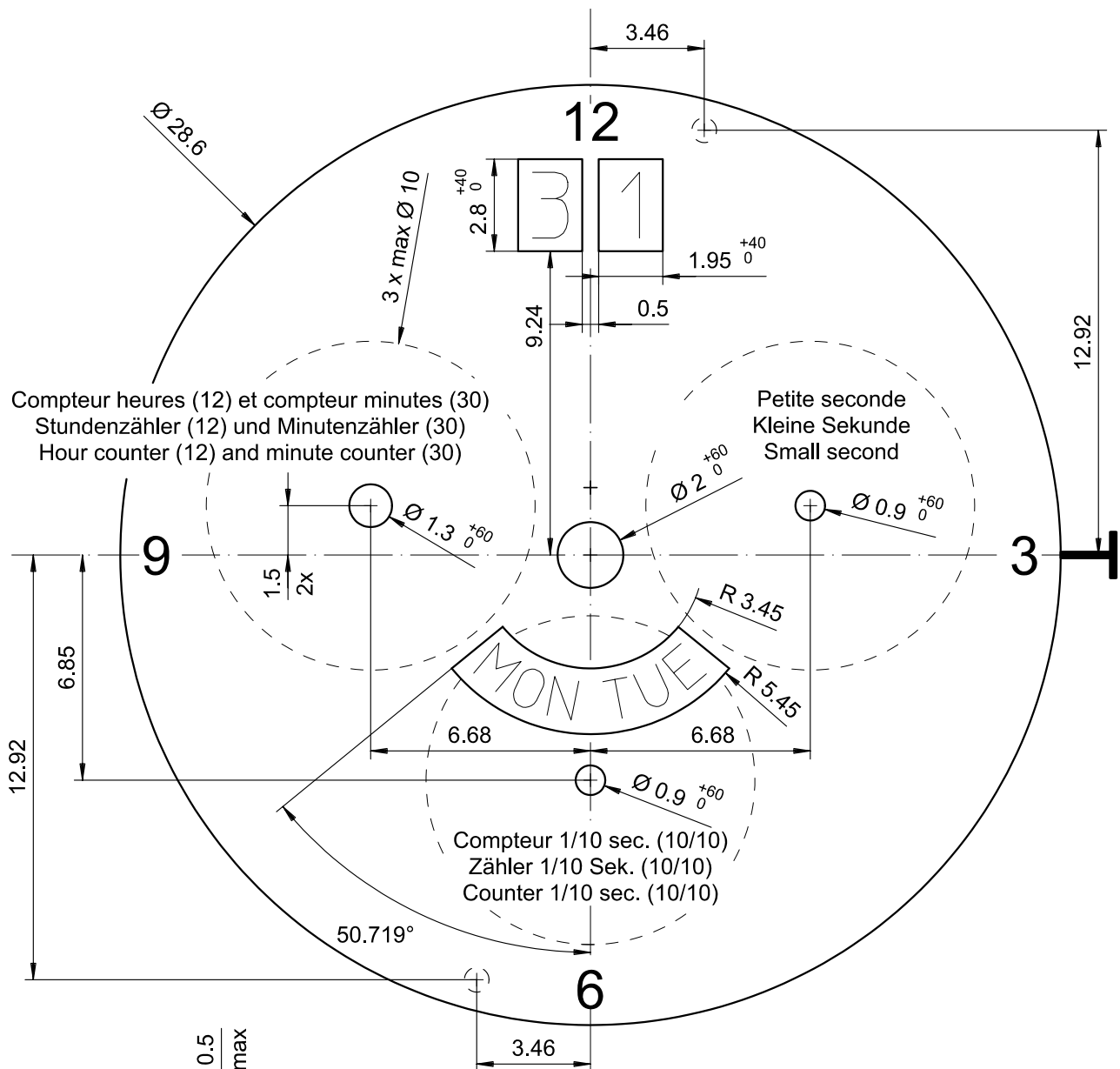

Compteur heures (12) et compteur minutes (30)  
 Stundenzähler (12) und Minutenzähler (30)  
 Hour counter (12) and minute counter (30)

Petite seconde  
 Kleine Sekunde  
 Small second

Compteur 1/10 sec. (10/10)  
 Zähler 1/10 Sek. (10/10)  
 Counter 1/10 sec. (10/10)

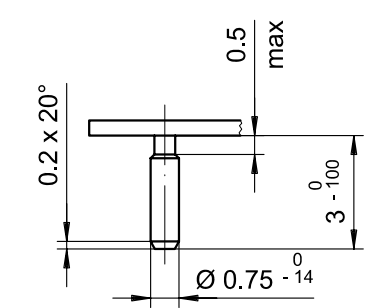

Epaisseur du cadran selon hauteur de l'aiguillage  
 Zifferblattdicke gemäss Zeigerwerkhöhen  
 Dial thickness according to hand fitting heights

Tige	Date	Jour
Stellw.	Datum	Tag
Stem	Date	Day
<b>3H</b>	<b>12H</b>	<b>6H</b>

<b>Cadran</b> <b>Zifferblatt</b> <b>Dial</b>	<b>12½"</b>	Issued	30 Nov 2007	mK
		Modified	10.Dez 2007 ÄA 3696	bk
		Released	YES	
		Tolerance	+/- 20 µm	
		Scale	5 : 1 (A4V)	
<b>RONDA</b>	<b>5051.C</b>	Sous réserve de modifications Aenderungen vorbehalten Modifications reserved		
		No.	5010.663	00

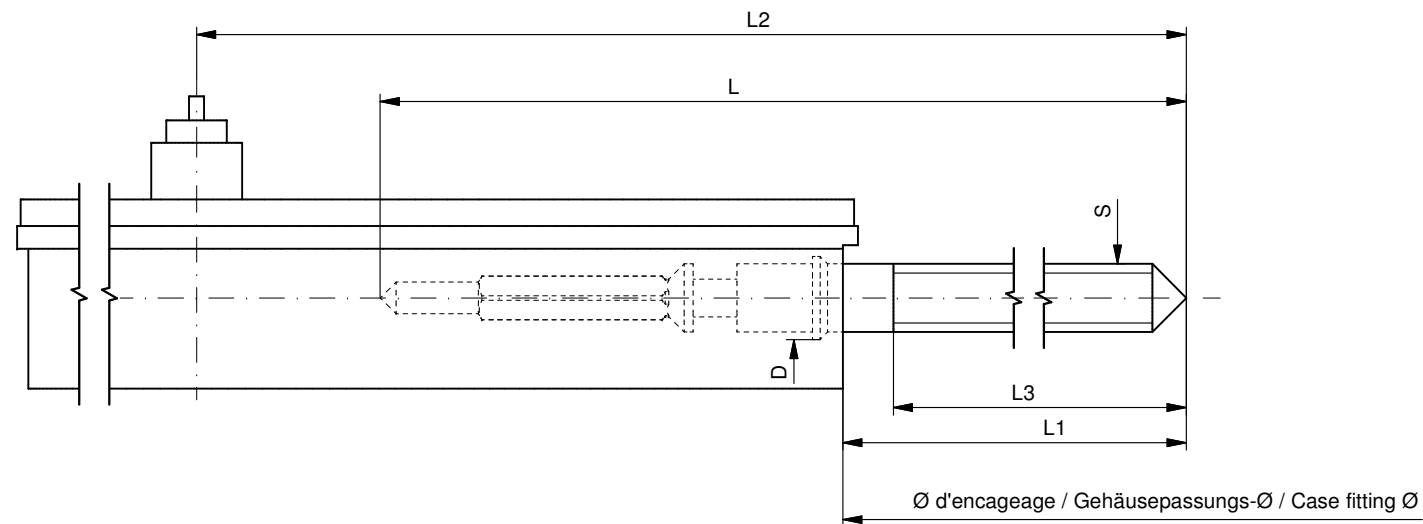

Tige de travail (intégrée dans le mouvement)  
 Arbeitstellwelle (im Werk eingebaut)  
 Working stem (implemented in the movement)

No. d'article Artikelnummer Part number	L	L1	L2	L3	S	D
3000.177.CO	20.00	10.23	24.23	10.15	0.90	1.10

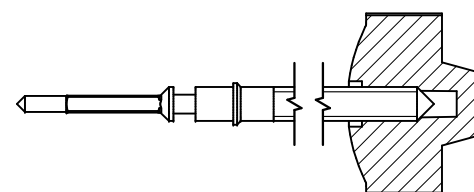

Couleur de la couronne Kronenfarbe Crown color	bleu foncé dunkelblau dark blue
Code	UN 5002

Tige (normale) / Stellwelle (normal) / Stem (normal)

No. d'article Artikelnummer Part number	L	L1	L2	L3	S	D
3000.177	20.00	10.23	24.23	10.15	0.90	1.10
3000.191	32.00	22.23	36.23	22.15	0.90	1.10

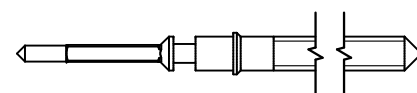

Couronne normale  
 Normale Krone  
 Normal crown

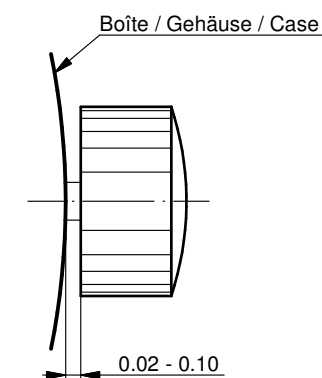

Couronne vissée  
 Geschraubte Krone  
 Screwed crown

Force ⇐ min. Kraft ⇐ min. Force ⇐ min.	10 N
Force ⇐ max. Kraft ⇐ max. Force ⇐ max.	15 N

Rallonge de tige / Stellwelle Verlängerung / Stem extension

No. d'article Artikelnummer Part number	L4	L5 (min)	L6	S1	S2	D1
3000.040	12.00	1.90	2.60	0.90	0.90	1.35

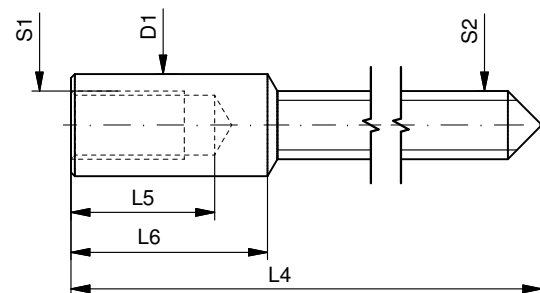

Tige (dimensions / forces)  
 Stellwelle (Dimensionen / Kräfte)  
 Stem (dimensions / forces)

**RONDA**

5010.B, 5020.B, 5021.D, 5030.D,  
 5040.B, 5040.D, 5040.E, 5040.F,  
 5050.B, 5050.C, 5051.C, 5130.B, 5130.D

Issued	05 Sep 2012	ds5222
Modified	17 Mär 2017 ÄA 34582	mg5224
Released	YES	
Tolerance	---	
Scale	10:1 (A3)	

Sous réserve de modifications  
 Änderungen vorbehalten  
 Modifications reserved

No.	5030.019	01
-----	----------	----

You have decided to buy a watch, which was assembled by a watchmaker using a Ronda movement. Please note that no watches are produced or distributed under the Ronda Brand.

**In case of repairs, guarantee claims and questions concerning the functioning of a watch, purchasers and consumers should contact their retailer or the watch manufacturer, for which the relevant information can be found in the sales or guarantee documentation provided with the watch.**

### Description of the display and control buttons

Display elements	5050.C	Display elements	5051.C
Second hand		Second hand	
Minute hand		Date	
Weekday		Minute hand	
Hour hand		Hour hand	
Minute counter		Minute counter	
Hour counter		Hour counter	
Second counter		Second counter	
1/2 second counter (running for the first 30 sec.)		Weekday	
Date		1/2 second counter (running for the first 30 sec.)	
<b>Control buttons</b>		<b>Control buttons</b>	
Push-button A & B		Push-button A & B	
01 Crown		Crown	

### Chronograph: Basic function

(Start / Stop / Reset)

Example:

- Start:** Press push-button A.
- Stop:** to stop the timing, press push-button A once more and read the chronograph counters:  
4h / 20 min / 38 sec / 1/2 sec
- Zero positioning:** Press push-button B. (The chronograph hands will be reset to their zero positions.)

05

### Chronograph: Accumulated timing

Example:

- Start:** (start timing)
- Stop:** (e.g. 15 min 5 sec following 1)
- Restart:** (timing is resumed)
- Stop:** (e.g. 5 min 12 sec following 3) = 20 min 17 sec (The accumulated measured time is shown)
- Reset:** The chronograph hands are returned to their zero positions.

**Please note:**  
 \* Following 4, the accumulation of the timing can be continued by pressing push-button A (Restart / Stop, Restart / Stop, ...).

06

### Setting the time

- \* Pull out the crown to position III (the watch stops).
- Turn the crown until you reach the correct time 8:45.
- \* Push the crown back into position I.

**Please note:**  
 \* In order to set the time to the exact second, 1 must be pulled out when the second hand is in position «60». Once the hour and minute hands have been set, 2 must be pushed back into position I at the exact second.

02

### Chronograph: Intermediate or interval timing

Example:

- Start:** (start timing)
- Display interval:** e.g. 20 minutes 17 seconds (timing continues in the background)
- Making up the measured time:** (the chronograph hands are quickly advanced to the ongoing measured time).
- Stop:** (Final time is displayed)
- Reset:** The chronograph hands are returned to their zero position

**Please note:**  
 \* Following 4, further intervals or intermediates can be displayed by pressing push-button B (display interval / make up measured time, ...).

07

### Setting the date (quick mode)

- Pull out the crown to position II (the watch continues to run).
- Turn the crown until the correct date 11 appears.
- Push the crown back into position I.

**Please note:**  
 During the date changing phase between approx. 9 PM and 12 PM, the date must be set to the date of the following day.  
 An extreme acceleration in setting the date with quick mode can induce a false date indication. The synchronization is re-established by setting the date from 01 till 31 (crown in position II).

03

### Adjusting the chronograph hands to zero position

Example:  
 One or several chronograph hands are not in their correct zero positions and have to be adjusted (e.g. following a battery change).

- Pull out the crown to position III (all chronograph hands are in their correct or incorrect zero position).
- Keep push-buttons A and B depressed simultaneously for at least 2 seconds (the second counter hand rotates by 360° → corrective mode is activated).

08

### Setting the date, weekday and time

Example:  
 - Date / time on the watch: 17 / 01:25  
 - Present date / time: 23 / 20:30

- Pull out the crown to position III (the watch stops).
- Turn the crown until yesterday's weekday 27 appears.
- Push the crown to position II.
- Turn the crown until yesterday's date appears 22.
- \* Pull out the crown to position III (the watch stops).
- Turn the crown until the correct date 23 and weekday 27 appears.
- \*\* Continue to turn the crown until the correct time 8:30 PM appears.
- Push the crown back into position I.

**Please note:**  
 \* To set your watch to the exact second, please refer to the chapter entitled «setting the time».  
 \*\* Please observe the AM/PM clock rhythm.

04

### Adjusting the second counter hand

Single step: A 1 x short  
 Continuous: A long

### Adjusting the next hand B

Single step: A 1 x short  
 Continuous: A long

### Adjusting the 1/2 second counter hand (position 6h)

Single step: A 1 x short  
 Continuous: A long

### Adjusting the next hand B

Single step: A 1 x short  
 Continuous: A long

### Adjusting the minute counter hand and the hour counter hand (mechanical coupled)

Single step: A 1 x short  
 Continuous: A long

3 Returning the crown to position I  
 Termination of the chronograph hands adjustment (can be carried out at any time).



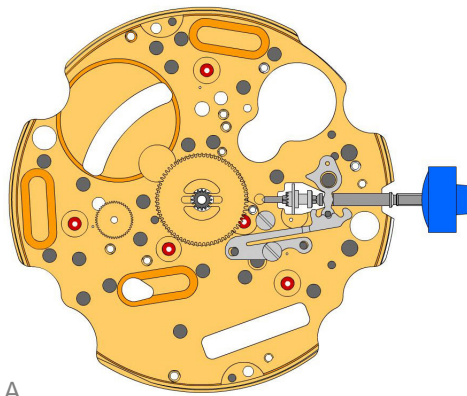

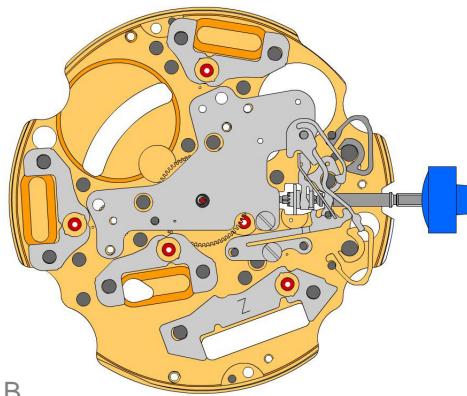

08



A







B

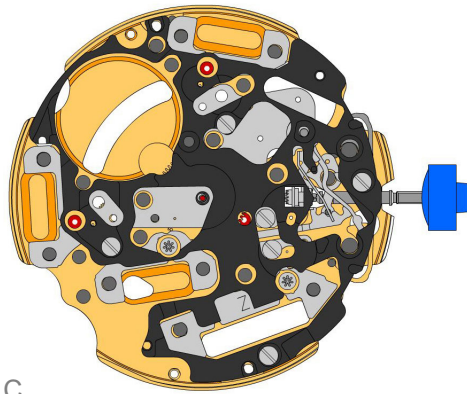



2000.574.G 1.		Main plate
3305.282.CO 2.		Cannon pinion with driver (Aig.2)
3301.244 3.		Hour wheel (counter 24h)
2030.017.CO 4.		Centre bridge Centre bridge held by 1 screw 4000.250. Parts 2030.017.CO, 3402.009.CO, 3004.223 and 3500.059 must be exchanged together.
4000.250 5.		Screw
3001.055.FI 6.		Sliding pinion
3000.177.CO 7.		Setting stem
3017.049 8.		Setting lever
3905.049 9.		Setting lever jumper (3 positions) Setting lever jumper held by 1 screw 4000.250.
3015.081 10.		Yoke (3 positions) Parts 3015.081 and 3905.067 must be exchanged together.
3905.067 11.		Yoke spring Tensioning the spring arm. Parts 3015.081 and 3905.067 must be exchanged together.
3406.030 12.		Pusher jumper B Put the grey jumper between the two posts on the further side.
3406.038 13.		Pusher jumper A Put the yellow jumper between the two posts on the closer side.
3622.040 14.		Stator Mark [Z] on stator.
3622.039 15.		Stator (counter 6h, 9h, chrono)
3622.039 16.		Stator (counter 6h, 9h, chrono)
3622.039 17.		Stator (counter 6h, 9h, chrono)
4000.250 18.		Screw



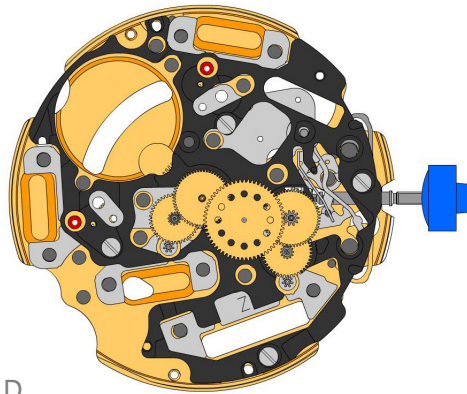





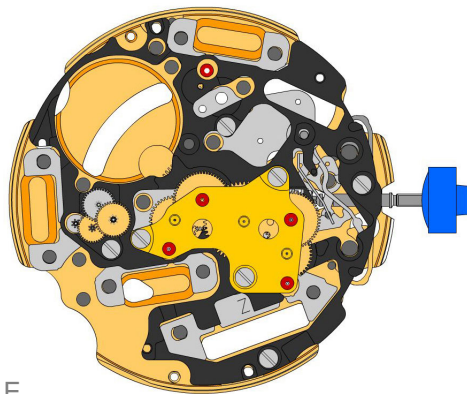

**C**

3603.079 19.		<b>Plastic bracket</b> Plastic bracket held by 4 screws 4000.250.
4000.250 20.		<b>Screw</b>
3715.094.RK 21.		<b>Rotor</b>
3715.094.RK 22.		<b>Rotor</b>

**D**





3147.046.CO 23.		<b>Intermediate wheel</b>
3136.142.CO 24.		<b>Second wheel (long)</b>
3147.047.CO 25.		<b>Intermediate wheel (chrono)</b>
3136.144.CO 26.		<b>Chronograph wheel (Aig.2)</b>
3122.056.CO 27.		<b>Third wheel</b>

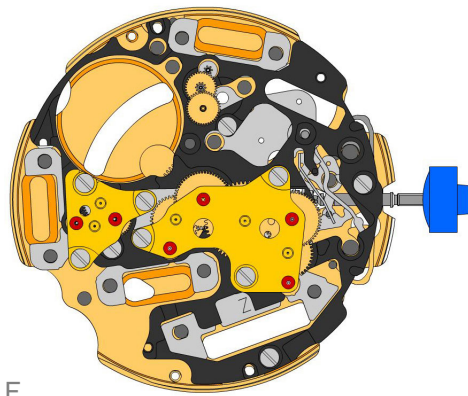

**E**

2020.148.G 28.		<b>Train wheel bridge</b> Train wheel bridge held by 3 screws 4000.250.
4000.250 29.		<b>Screw</b>
3715.095.RK 30.		<b>Rotor</b>
3147.048.CO 31.		<b>Intermediate wheel (counter)</b>
3007.056.CO 32.		<b>Minute wheel (counter 24h)</b>
3402.008.CO 33.		<b>Minute counting wheel</b>





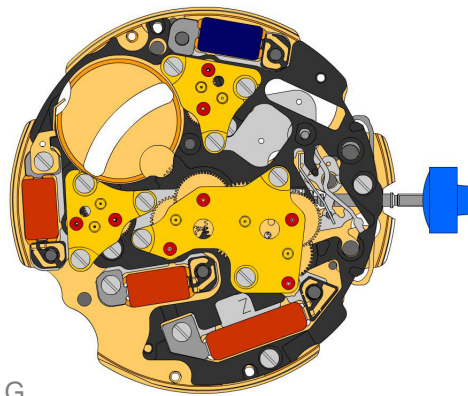







F

2020.149.G 34.		<b>Counter train wheel bridge</b> Counter train wheel bridge held by 3 screws 4000.250.
4000.250 35.		<b>Screw</b>
3715.095.RK 36.		<b>Rotor</b>
3147.053.CO 37.		<b>Intermediate wheel (counter 1/10sec)</b>
3402.009.CO 38.		<b>Counting wheel 1/10 sec</b> Parts 2030.017.CO, 3402.009.CO, 3004.223 and 3500.059 must be exchanged together.





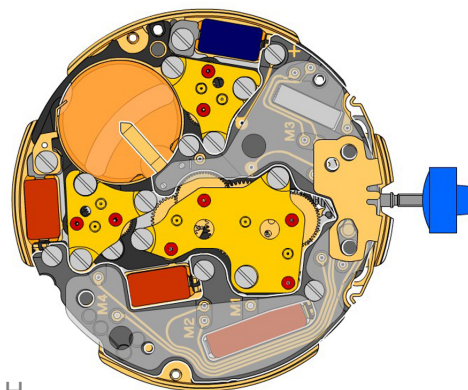

G

2020.149.G 39.		<b>Counter train wheel bridge</b> Counter train wheel bridge held by 3 screws 4000.250.
4000.250 40.		<b>Screw</b>
3621.053.RK 41.		<b>Coil</b> Attention: Please hold the coil only on the grey coil core. Coil held by 1 screw 4000.250.
3621.054.RK 42.		<b>Coil (counter 9h, chrono)</b> Attention: Please hold the coil only on the grey coil core. Coil held by 1 screw 4000.250.
3621.054.RK 43.		<b>Coil (counter 9h, chrono)</b> Attention: Please hold the coil only on the grey coil core. Coil held by 1 screw 4000.250.
3621.055.RK 44.		<b>Coil (counter 6h)</b> Attention: Please hold the coil only on the grey coil core. Coil held by 1 screw 4000.250.
4000.250 45.		<b>Screw</b>
3601.118 46.		<b>Contact strip</b> Contact strip held by 1 screw 4000.250.
4000.250 47.		<b>Screw</b>
3603.034 48.		<b>Battery insulator</b>



H

3612.144.5050 49.		<b>Electronic module</b> Electronic module held by 5 screws 4000.248. Electronic measurements may be realised now.
4000.248 50.		<b>Screw</b>
3603.069 51.		<b>Circuit insulator</b>
3601.107.G 52.		<b>Pusher contact spring</b>

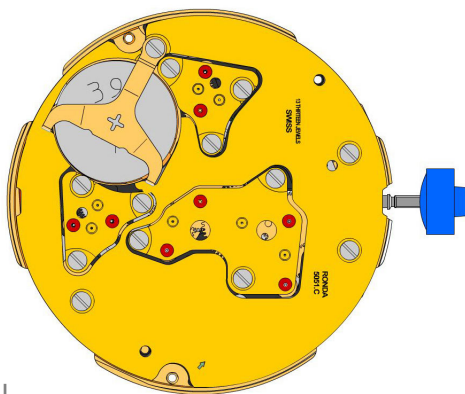





2130.137.G.M01.5051C  
53.  **Electronic module cover**  
Electronic module cover held by 3 screws 4000.250.

3600.010.HGF  
54.  **Battery 395**

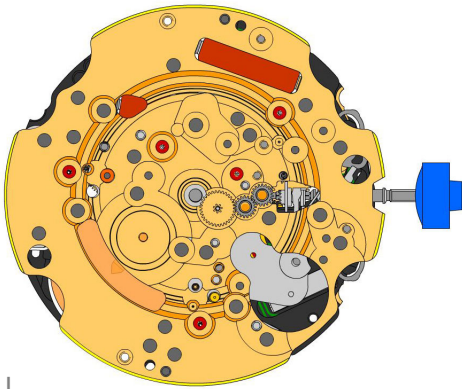



3601.109.G  
55.  **Bridge +**  
Bridge held by 1 screw 4000.250.

4000.250  
56.  **Screw**

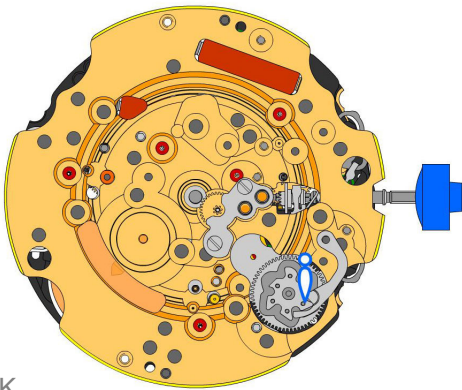



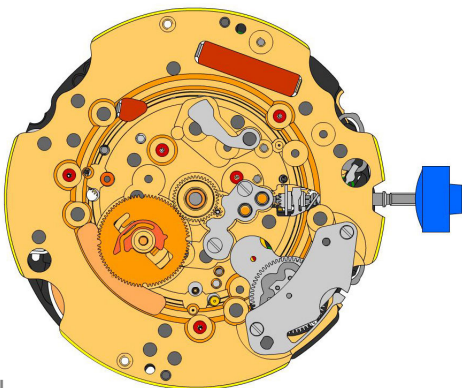

**J**

2000.574.G 57.		Main plate
3004.164 58.		Setting wheel
3004.164 59.		Setting wheel
3007.054.CO 60.		Minute wheel

**K**





2130.143 61.		Minute train bridge Minute train bridge held by 2 screws 4000.305.
4000.305 62.		Screw
3004.223 63.		Tens indicator driving wheel Parts 2030.017.CO, 3402.009.CO, 3004.223 and 3500.059 must be exchanged together. The short tooth of the tens indicator driving wheel must point to the center of the movement.
3500.059 64.		Tens jumper Parts 2030.017.CO, 3402.009.CO, 3004.223 and 3500.059 must be exchanged together.

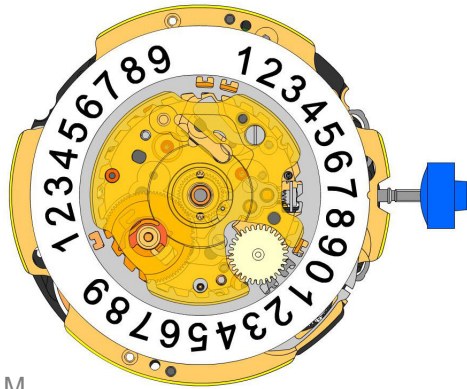

**L**

2130.142 65.		Tens jumper maintaining plate Tens jumper maintaining plate held by 2 screws 4000.306. Place the spring loaded bracket outside of the tens jumper.
4010.306 66.		Screw
3301.242 67.		Hour wheel (Aig.2)
3315.016 68.		Friction spring
3004.224.CO 69.		Date indicator driving wheel
3500.049 70.		Date jumper





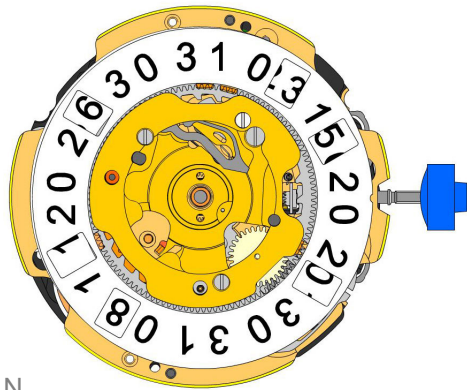

M

3504.214.AF.1.A 71.		Units indicator (standard) Nick of the indicator at 3 o'clock.
3147.054 72.		Tens intermediate wheel
2130.163 73.		Date indicator maintaining plate Date indicator maintaining plate held by 1 screw 4000.282.
4000.282 74.		Screw
3905.070 75.		Date jumper spring Insert the date jumper spring in the provided opening.







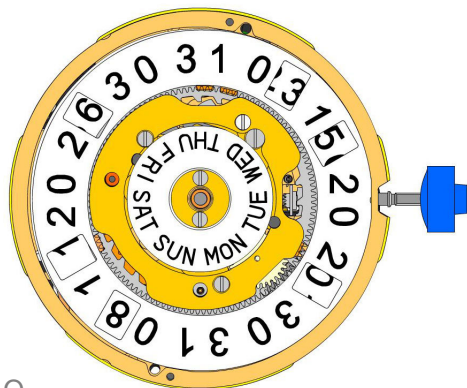



N

3504.216.AF.1.A 76.		Tens indicator (standard) Nick of the indicator at 3 o'clock.
3500.055 77.		Day jumper Tensioning the spring arm.
3004.175 78.		Day finger
2130.162.G 79.		Date mechanism maintaining plate Date mechanism maintaining plate held by 2 screws 4000.312 and 1 screw 4000.300.
4000.312 80.		Screw



O

3508.155.AQ.E.A 81.		Day indicator (standard)
2130.164.G 82.		Day indicator maintaining plate Day indicator maintaining plate held by 2 screws 4000.311.
4000.311 83.		Screw
3506.072.G 84.		Dial support

8200 85.		Moebius 8200
9014 86.		Moebius 9014
124 87.		Jismaa 124
9020 88.		Moebius 9020

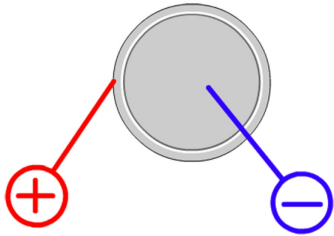

Battery	<b>395</b>
Voltage	<b>1.55 V</b>

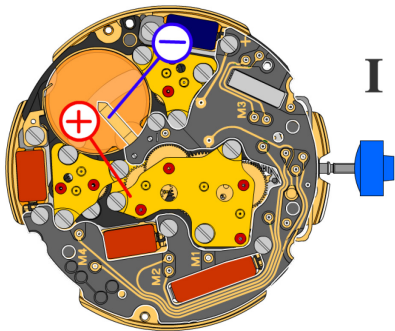

*Setting stem in position I, calendar not in gear,  
60 s measuring interval for rate and consumption:*

Typical consumption	<b>1.32 <math>\mu</math>A</b>
Maximal consumption	<b>1.65 <math>\mu</math>A</b>
Rate	<b>-10s/M. .. +20s/M.</b>
Lower working voltage limit	<b>1.20 V</b>

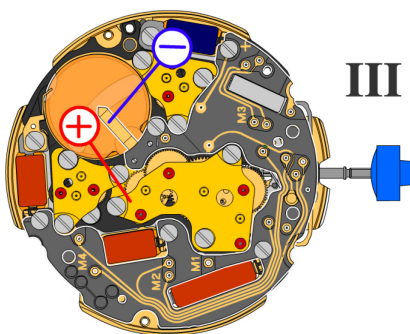

*Setting stem in position III, 60 s measuring interval:*

Typical consumption	<b>0.10 <math>\mu</math>A</b>
Maximal consumption	<b>0.30 <math>\mu</math>A</b>

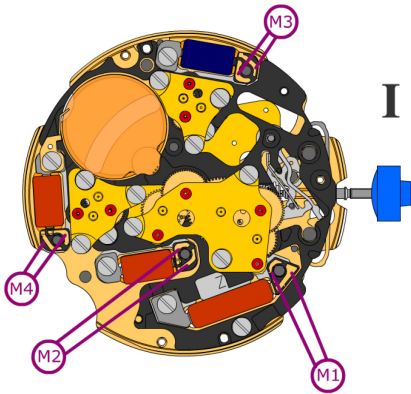

Coil resistance M1 **1.90 k $\Omega$  .. 2.10 k $\Omega$**

Coil resistance M2 **1.68 k $\Omega$  .. 1.88 k $\Omega$**

Coil resistance M3 **1.68 k $\Omega$  .. 1.88 k $\Omega$**

Coil resistance M4 **1.68 k $\Omega$  .. 1.88 k $\Omega$**

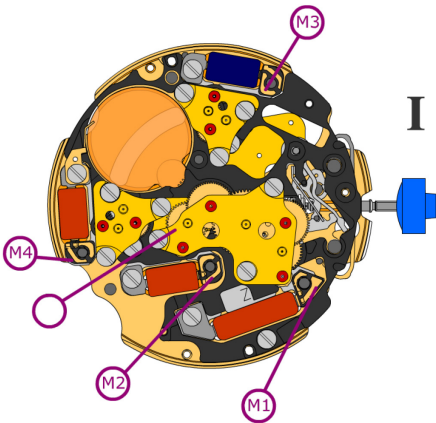

Coil isolation M1/M2/M3/M4  **$\infty$  k $\Omega$**

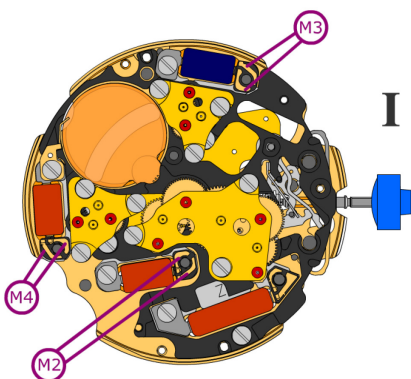

*Signal generator (4.9 ms, 8 Hz):*

Lower working voltage limit  
M2/M3/M4 **1.20 V**



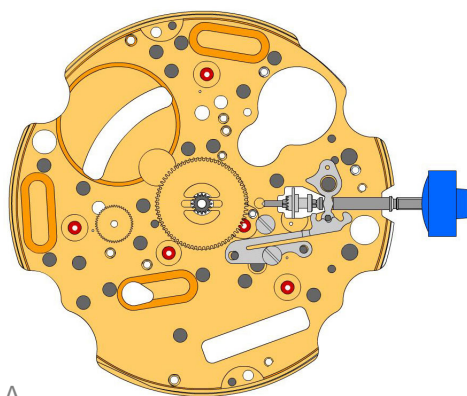



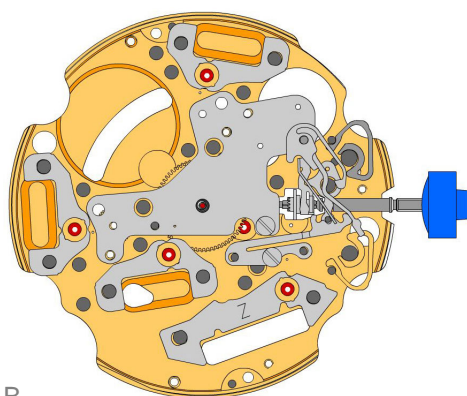

















A





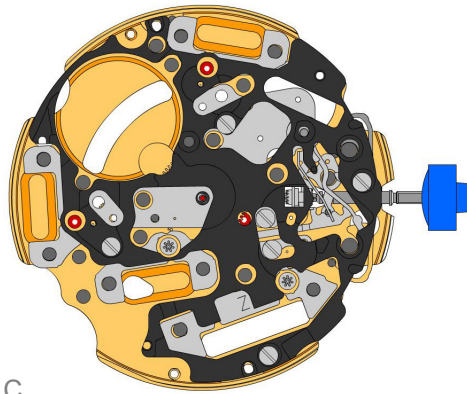

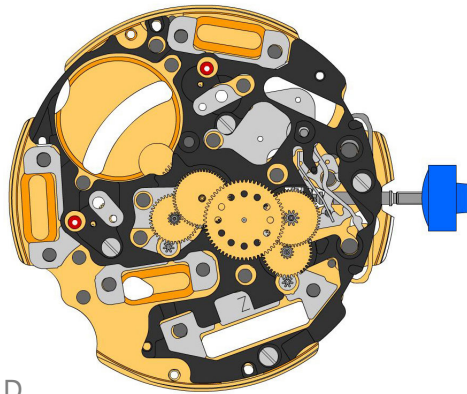

B

2000.574.G 1.		Main plate
3305.282.CO 2.		Cannon pinion with driver (Aig.2)
3301.244 3.		Hour wheel (counter 24h)
2030.032.CO 4.		Centre bridge Centre bridge held by 1 screw 4000.250.
4000.250 5.		Screw
3001.055.FI 6.		Sliding pinion
3000.177.CO 7.		Setting stem
3017.049 8.		Setting lever
3905.049 9.		Setting lever jumper (3 positions) Setting lever jumper held by 1 screw 4000.250.
3015.081 10.		Yoke (3 positions) Parts 3015.081 and 3905.067 must be exchanged together.
3905.067 11.		Yoke spring Tensioning the spring arm.
3406.030 12.		Pusher jumper B Put the grey jumper between the two posts on the further side.
3406.038 13.		Pusher jumper A Put the yellow jumper between the two posts on the closer side.
3622.040 14.		Stator Mark [Z] on stator.
3622.039 15.		Stator (counter 6h, 9h, chrono)
3622.039 16.		Stator (counter 6h, 9h, chrono)
3622.039 17.		Stator (counter 6h, 9h, chrono)
4000.250 18.		Screw





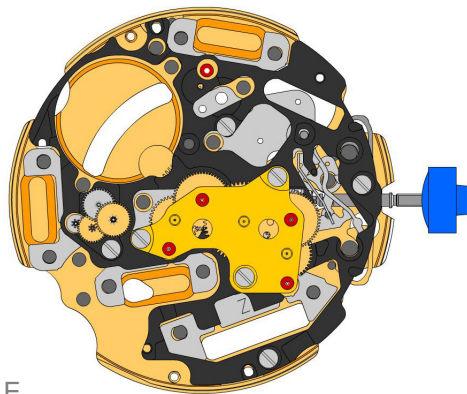

**C**

3603.079 19.		<b>Plastic bracket</b> Plastic bracket held by 4 screws 4000.250.
4000.250 20.		<b>Screw</b>
3715.094.RK 21.		<b>Rotor</b>
3715.094.RK 22.		<b>Rotor</b>





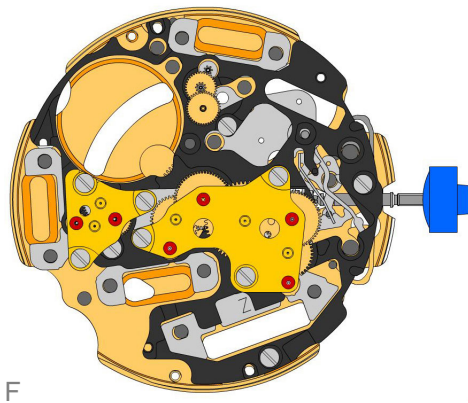

**D**

3147.046.CO 23.		<b>Intermediate wheel</b>
3136.142.CO 24.		<b>Second wheel (long)</b>
3147.047.CO 25.		<b>Intermediate wheel (chrono)</b>
3136.144.CO 26.		<b>Chronograph wheel (Aig.2)</b>
3122.056.CO 27.		<b>Third wheel</b>









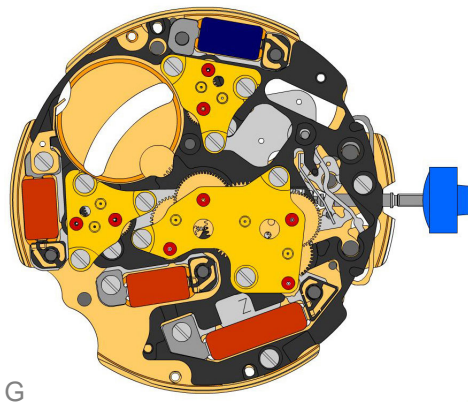

**E**

2020.148.G 28.		<b>Train wheel bridge</b> Train wheel bridge held by 3 screws 4000.250.
4000.250 29.		<b>Screw</b>
3715.095.RK 30.		<b>Rotor</b>
3147.048.CO 31.		<b>Intermediate wheel (counter)</b>
3007.056.CO 32.		<b>Minute wheel (counter 24h)</b>
3402.008.CO 33.		<b>Minute counting wheel</b>







2020.149.G 34.		<b>Counter train wheel bridge</b> Counter train wheel bridge held by 3 screws 4000.250.
4000.250 35.		<b>Screw</b>
3715.095.RK 36.		<b>Rotor</b>
3147.053.CO 37.		<b>Intermediate wheel (counter 1/10sec)</b>
3402.016.CO 38.		<b>Counting wheel 1/10 sec</b>

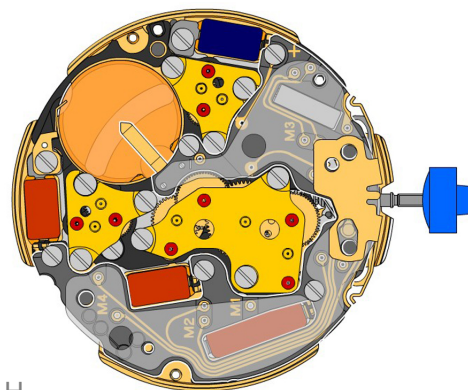

2020.149.G 39.		<b>Counter train wheel bridge</b> Counter train wheel bridge held by 3 screws 4000.250.
4000.250 40.		<b>Screw</b>
3621.053.RK 41.		<b>Coil</b> Attention: Please hold the coil only on the grey coil core. Coil held by 1 screw 4000.250.
3621.054.RK 42.		<b>Coil (counter 9h, chrono)</b> Attention: Please hold the coil only on the grey coil core. Coil held by 1 screw 4000.250.
3621.054.RK 43.		<b>Coil (counter 9h, chrono)</b> Attention: Please hold the coil only on the grey coil core. Coil held by 1 screw 4000.250.
3621.055.RK 44.		<b>Coil (counter 6h)</b> Attention: Please hold the coil only on the grey coil core. Coil held by 1 screw 4000.250.
4000.250 45.		<b>Screw</b>
3601.118 46.		<b>Contact strip</b> Contact strip held by 1 screw 4000.250.
4000.250 47.		<b>Screw</b>
3603.034 48.		<b>Battery insulator</b>



3612.144.5050 49.		<b>Electronic module</b> Electronic module held by 5 screws 4000.248. Electronic measurements may be realised now.
4000.248 50.		<b>Screw</b>
3603.069 51.		<b>Circuit insulator</b>
3601.107.G 52.		<b>Pusher contact spring</b>

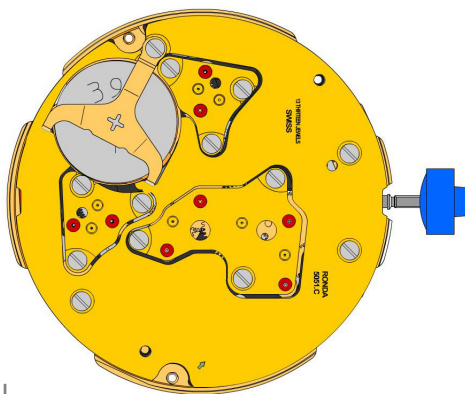





2130.137.G.M01.5051C  
53.  **Electronic module cover**  
Electronic module cover held by 3 screws 4000.250.

3600.010.HGF  
54.  **Battery 395**

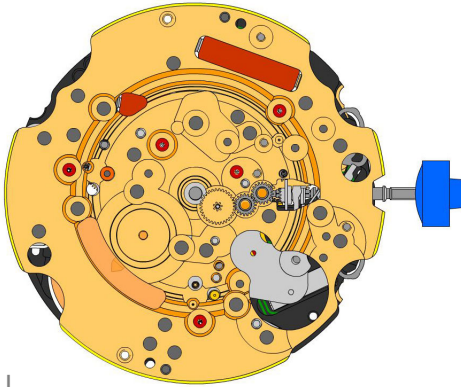



3601.109.G  
55.  **Bridge +**  
Bridge held by 1 screw 4000.250.

4000.250  
56.  **Screw**

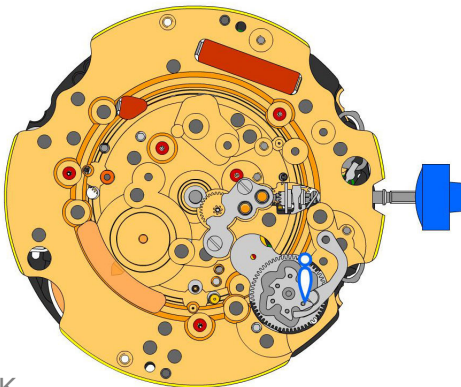



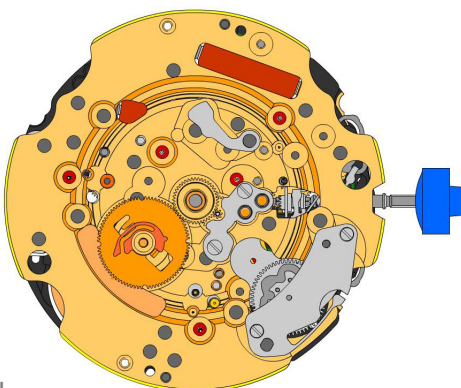

**J**

2000.574.G 57.		Main plate
3004.164 58.		Setting wheel
3004.164 59.		Setting wheel
3007.054.CO 60.		Minute wheel

**K**





2130.143 61.		Minute train bridge Minute train bridge held by 2 screws 4000.305.
4000.305 62.		Screw
3004.227 63.		Tens indicator driving wheel The short tooth of the tens indicator driving wheel must point to the center of the movement.
3500.075 64.		Tens jumper

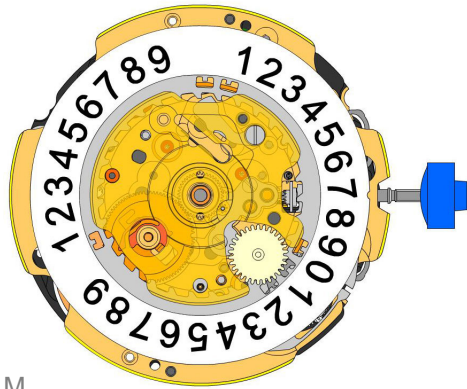

**L**

2130.142 65.		Tens jumper maintaining plate Tens jumper maintaining plate held by 2 screws 4000.306. Place the spring loaded bracket outside of the tens jumper.
4010.306 66.		Screw
3301.242 67.		Hour wheel (Aig.2)
3315.016 68.		Friction spring
3004.224.CO 69.		Date indicator driving wheel
3500.049 70.		Date jumper





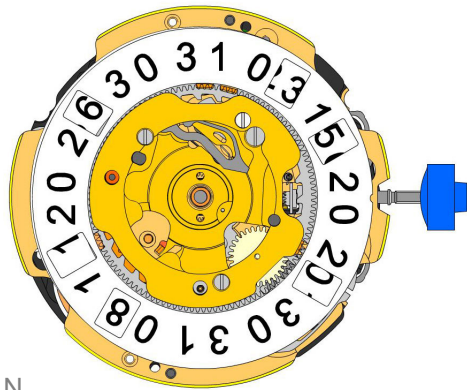

M

3504.214.AF.1.A 71.		Units indicator (standard) Nick of the indicator at 3 o'clock.
3147.054 72.		Tens intermediate wheel
2130.163 73.		Date indicator maintaining plate Date indicator maintaining plate held by 1 screw 4000.282.
4000.282 74.		Screw
3905.070 75.		Date jumper spring Insert the date jumper spring in the provided opening.







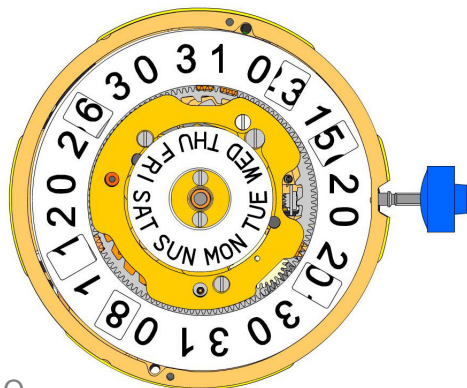



N

3504.216.AF.1.A 76.		Tens indicator (standard) Nick of the indicator at 3 o'clock.
3500.055 77.		Day jumper
3004.175 78.		Day finger
2130.162.G 79.		Date mechanism maintaining plate Date mechanism maintaining plate held by 2 screws 4000.312 and 1 screw 4000.300.
4000.312 80.		Screw



O

3508.155.AQ.E.A 81.		Day indicator (standard)
2130.164.G 82.		Day indicator maintaining plate Day indicator maintaining plate held by 2 screws 4000.311.
4000.311 83.		Screw
3506.072.G 84.		Dial support

8200 85.		Moebius 8200
9014 86.		Moebius 9014
124 87.		Jismaa 124
9020 88.		Moebius 9020

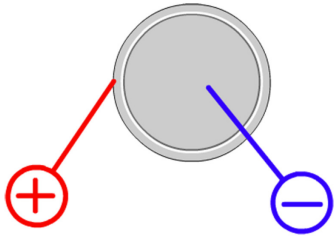

Battery	<b>395</b>
Voltage	<b>1.55 V</b>

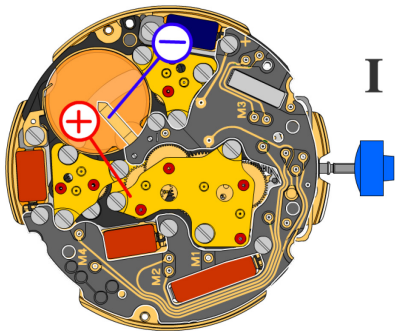

*Setting stem in position I, calendar not in gear,  
60 s measuring interval for rate and consumption:*

Typical consumption	<b>1.32 <math>\mu</math>A</b>
Maximal consumption	<b>1.65 <math>\mu</math>A</b>
Rate	<b>-10s/M. .. +20s/M.</b>
Lower working voltage limit	<b>1.20 V</b>

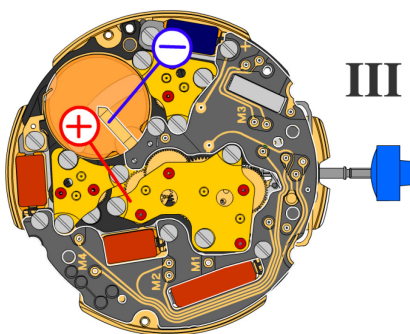

*Setting stem in position III, 60 s measuring interval:*

Typical consumption	<b>0.10 <math>\mu</math>A</b>
Maximal consumption	<b>0.30 <math>\mu</math>A</b>



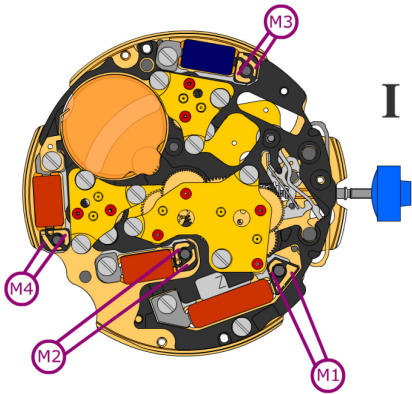

Coil resistance M1 **1.90 k $\Omega$  .. 2.10 k $\Omega$**

Coil resistance M2 **1.68 k $\Omega$  .. 1.88 k $\Omega$**

Coil resistance M3 **1.68 k $\Omega$  .. 1.88 k $\Omega$**

Coil resistance M4 **1.68 k $\Omega$  .. 1.88 k $\Omega$**

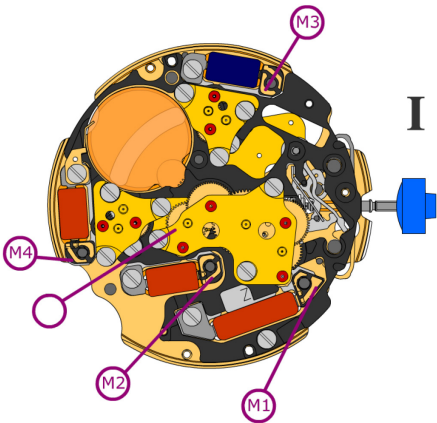

Coil isolation M1/M2/M3/M4  **$\infty$  k $\Omega$**

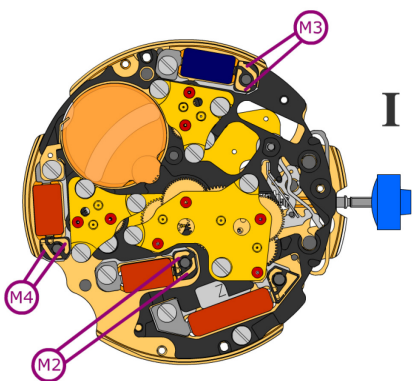

*Signal generator (4.9 ms, 8 Hz):*

Lower working voltage limit  
M2/M3/M4 **1.20 V**