

Watch Movement Specification and Drawing

Basic Chronograph Movement

VD56C

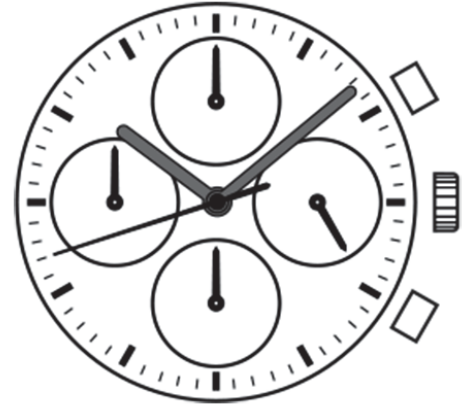

Movement Size: **12 3/4"**
 Diameter: **Φ29.50mm**
 Height: **3.97mm**

Items	Ver.	Items	Ver.
Specification	1		
Appearance	1		
Casing	1		
Hand Fitting	1		
Hand Setting Stem	1		
Dial	1		
Assembly Plan - 1	1		
Assembly Plan - 2	1		
Hands	1		

CAL.VD56C 12 $\frac{3}{4}$ Ligne Quartz Movement

Three Hands with 4 Eyes

Small Chronograph 1 / 10 Second, Small Chronograph Second & Minute, 24 Hour Indicator Hands

1. FUNCTION

- Jewel 0 jewel
- Accuracy Less than ± 20 seconds / month (Normal temperature range)
- Battery life Approx. 3 years
- Regulation hands unbalance
 - Hour hand : Less than $0.60 \mu\text{N}\cdot\text{m}$ (60 mg $\cdot\text{mm}$)
 - Minute hand : Less than $0.90 \mu\text{N}\cdot\text{m}$ (90 mg $\cdot\text{mm}$)
 - Second hand : Less than $0.09 \mu\text{N}\cdot\text{m}$ (9 mg $\cdot\text{mm}$)
 - Small chronograph hands : Less than $0.05 \mu\text{N}\cdot\text{m}$ (5 mg $\cdot\text{mm}$)
 - Small 24 hour indicator hand : Less than $0.07 \mu\text{N}\cdot\text{m}$ (7 mg $\cdot\text{mm}$)
- Additional function
 - Chronograph : up to 1 minute in 1/10 second (2 seconds per round)
: up to 60 minutes in 1 second split time
 - 24 hour indicator (Synchronized regular hour hand)

2. USE AND TEST CONDITION

- Battery SR920SW (Recommended battery is SEIZAIKEN)
- Operation temperature range From - 5 °C to + 50 °C
- Antimagnetic ≥ 1600 A / m (Direct current magnetic field)
- Test of accuracy 10 seconds (Duration of measurement)

*** All specifications are subject to change without notice.**

Appearance

VD56C

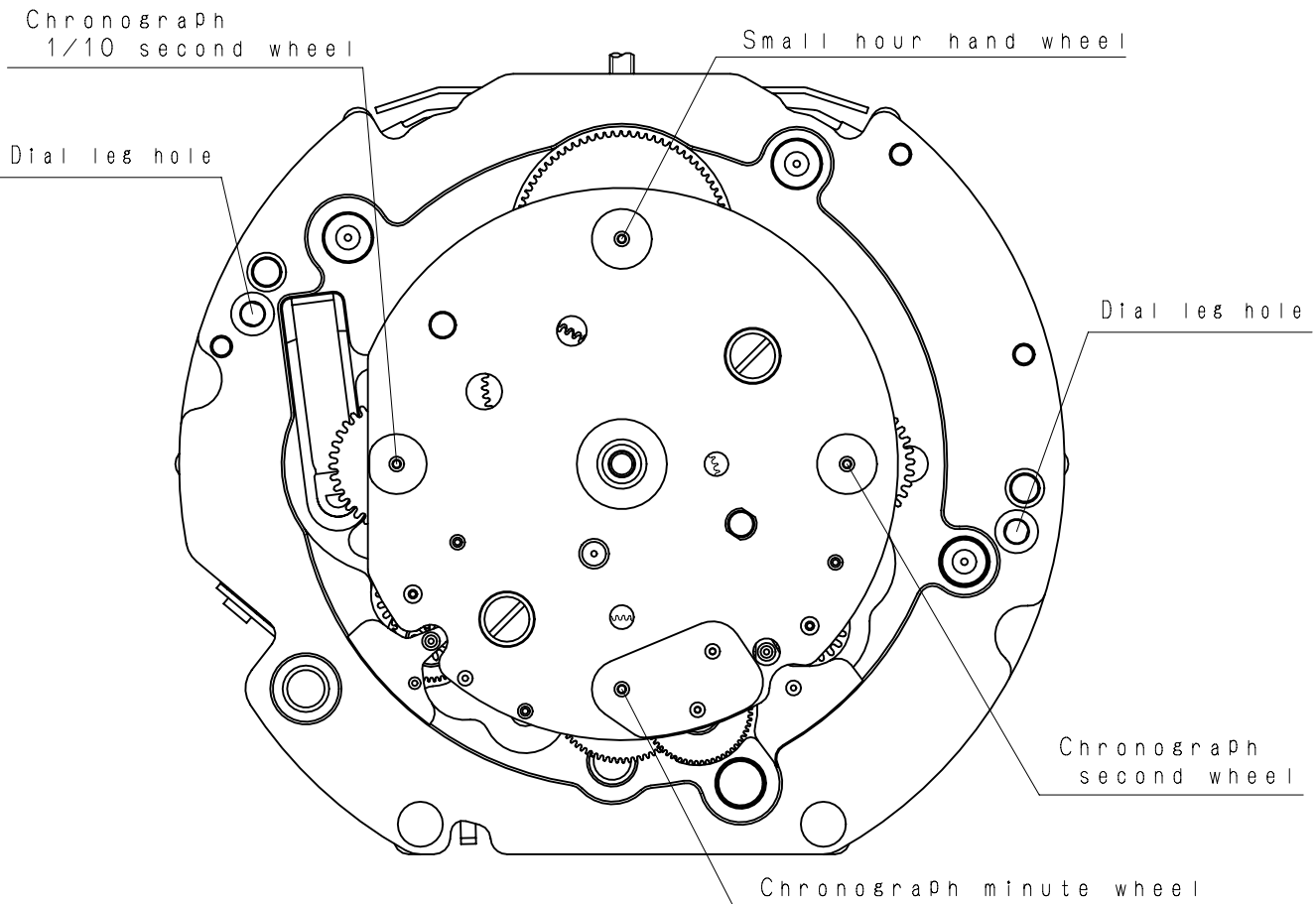
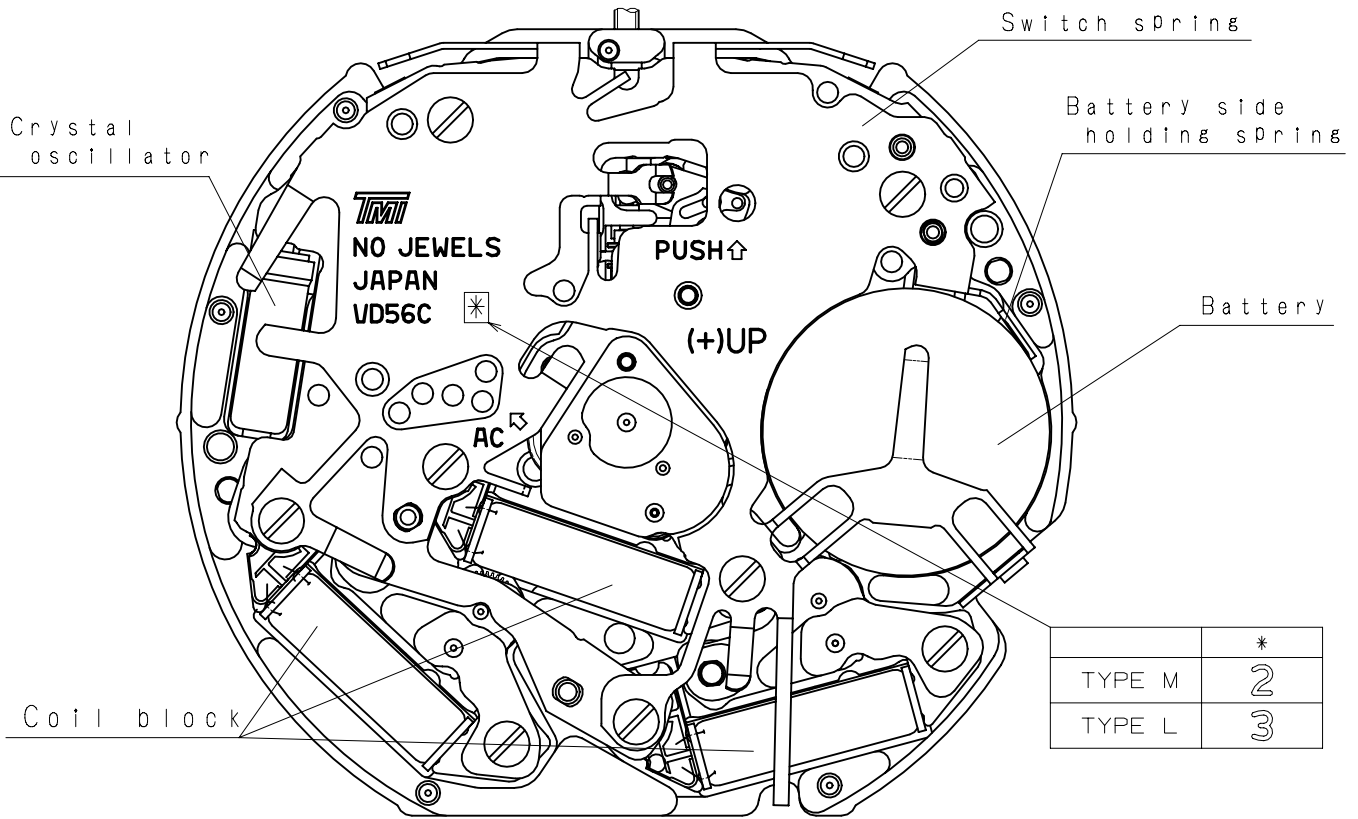

Version : 1

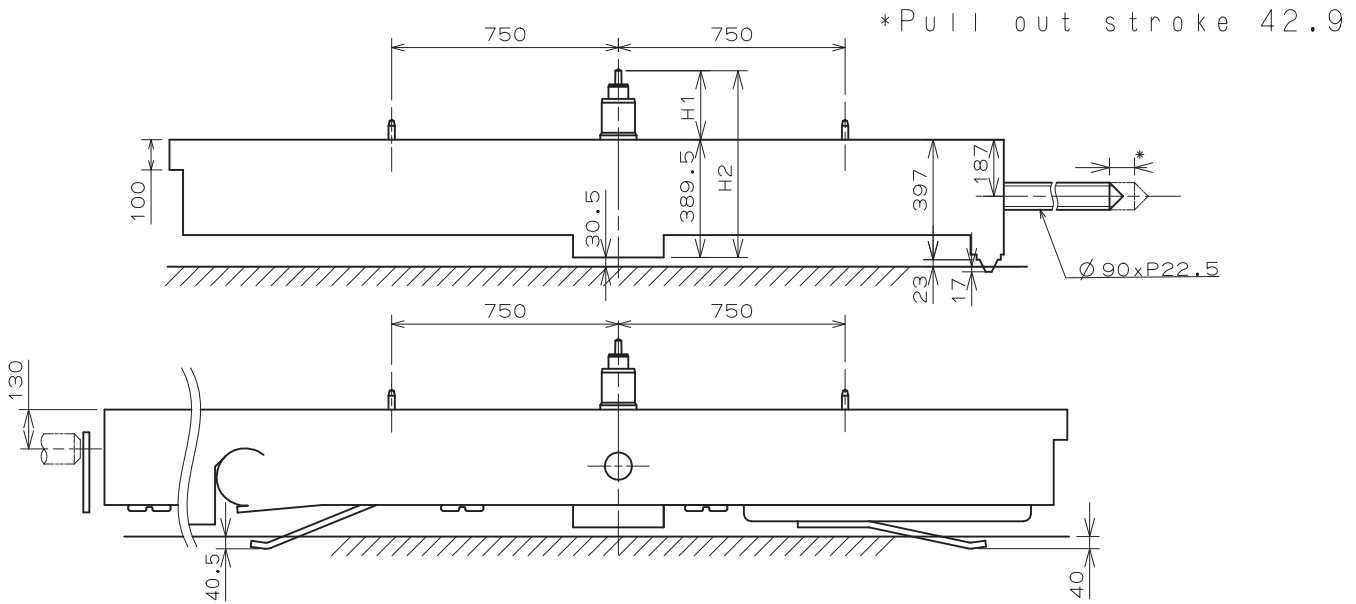

Center post 中心柱位		TYPE M 一般針高	TYPE L 高針
Maximum height from main plate surface 與機芯平面的最大高度	H1	228	273
Total height incl. movement 機芯總高度	H2	617.5	662.5

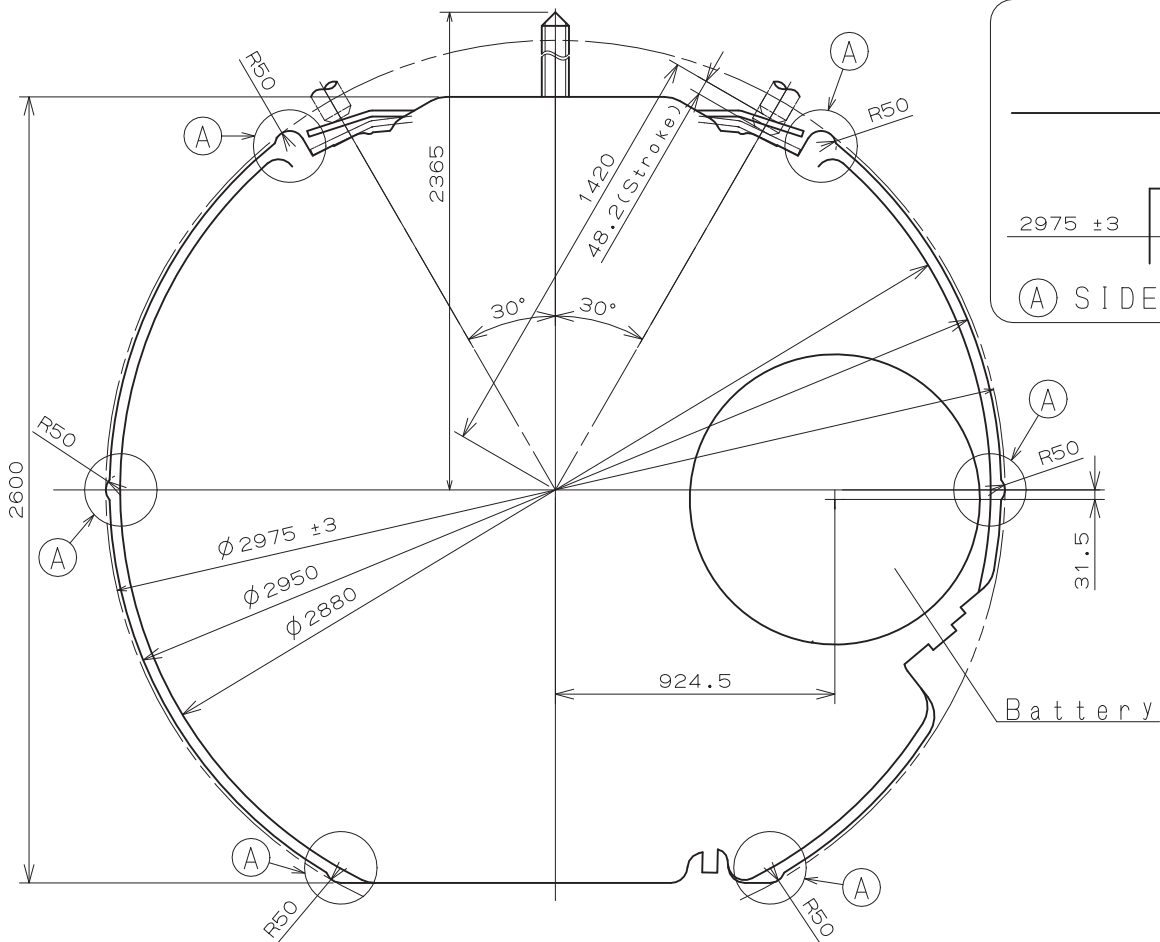

- * Hour hand unbalance $\leq 0.6 \mu\text{N}\cdot\text{m}$ (60mg·mm)
- * Minute hand unbalance $\leq 0.9 \mu\text{N}\cdot\text{m}$ (90mg·mm)
- * Second hand unbalance $\leq 0.09 \mu\text{N}\cdot\text{m}$ (9mg·mm)
- * Chronograph hand unbalance $\leq 0.05 \mu\text{N}\cdot\text{m}$ (5mg·mm)
- * Small Hour hand unbalance $\leq 0.07 \mu\text{N}\cdot\text{m}$ (7mg·mm)

	H1	H2
TYPE M 一般針高	99.5	141
TYPE L 高針	144.5	186

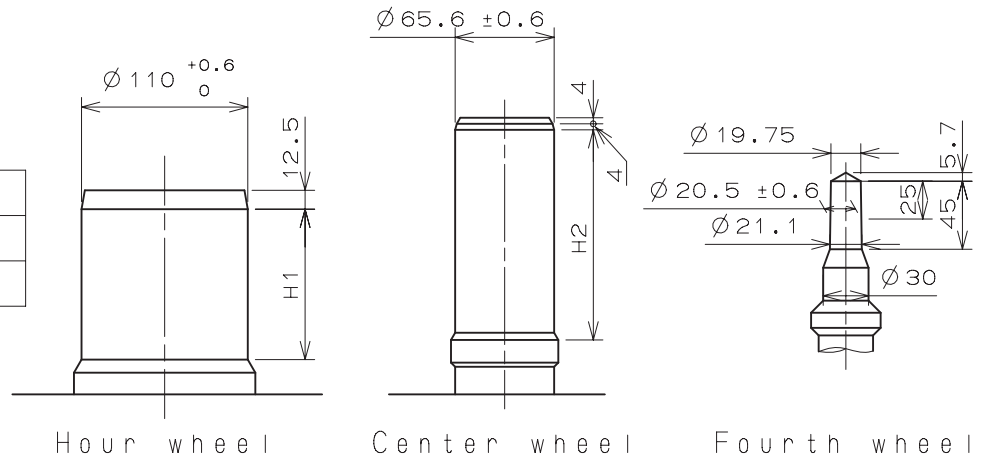

Part name		Part No.	
		TYPE M 一般針高	TYPE L 高針
Hour wheel	時針輪	0271 406	0273 036
Center wheel	分針輪	0221 205	0221 204
Fourth wheel	秒針輪	0241 177	0241 480
Small hour hand wheel	小時針輪	0157 011	0157 035
Chronograph minute wheel	計時分針輪	0902 007	0902 003
Chronograph second wheel	計時秒針輪	0888 008	0888 010
Chronograph 1/10 second wheel	1/10計時秒針輪	0888 008	0888 010

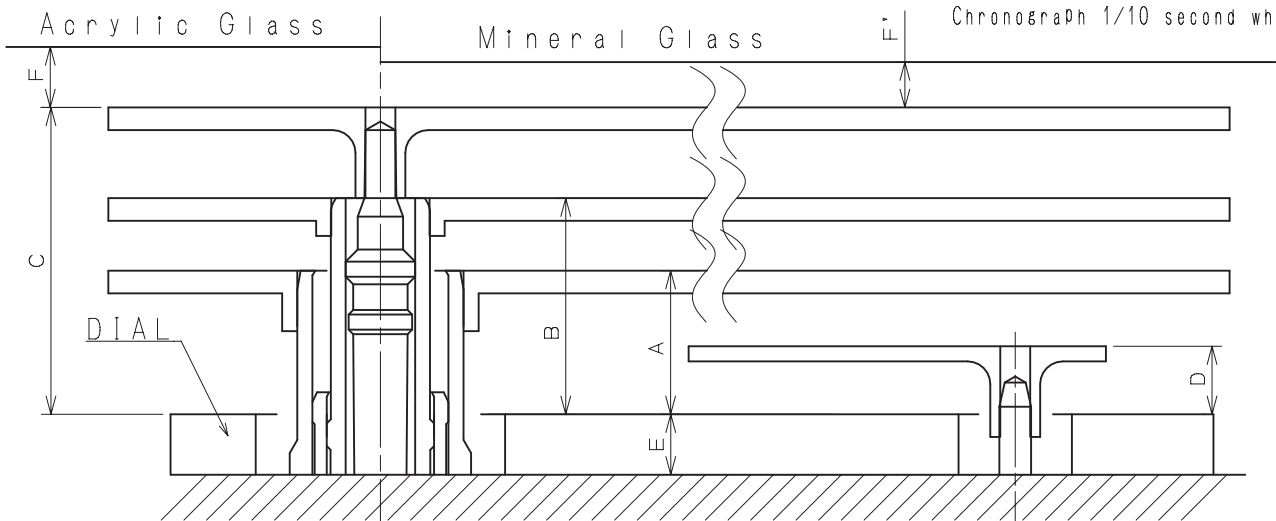
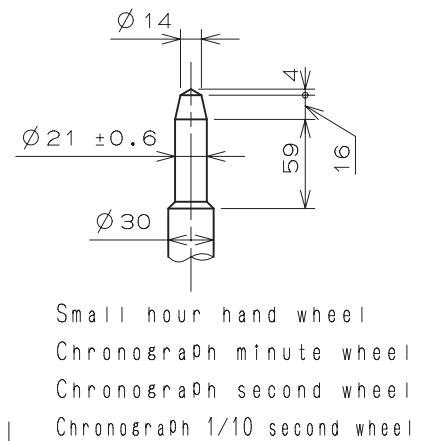

	A	B	C	D	E	F	F'
TYPE M 一般針高	95	143	203	45	40	50	40
TYPE L 高針	95	143	203	45	85	50	40

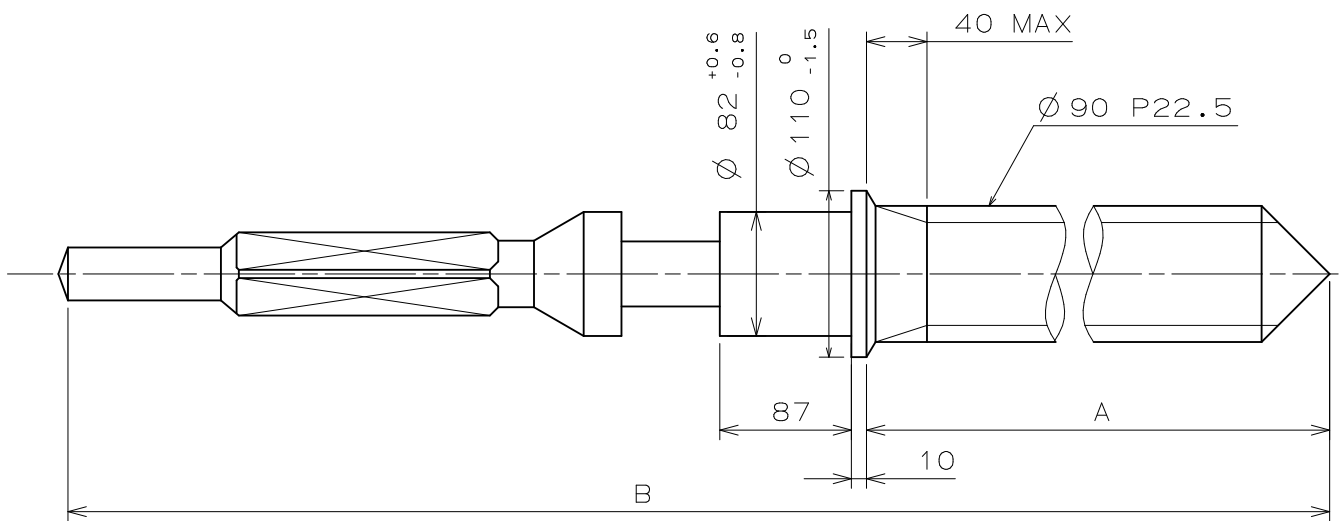

	Part No.	A	B
TYPE A	0351 178	1508	2036

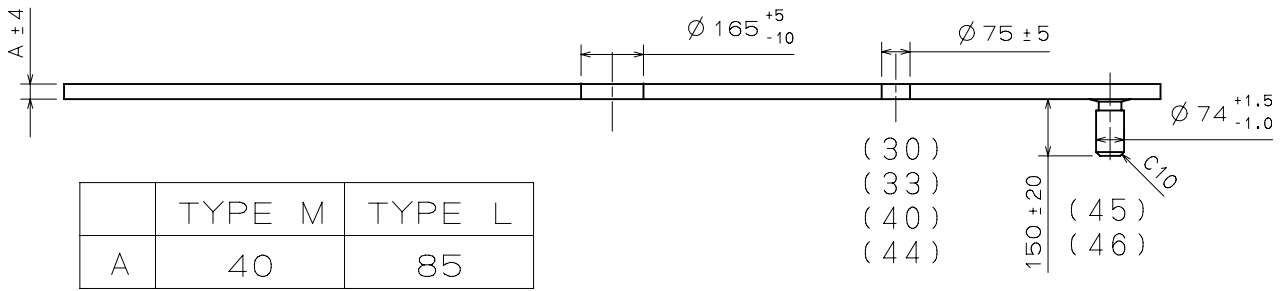
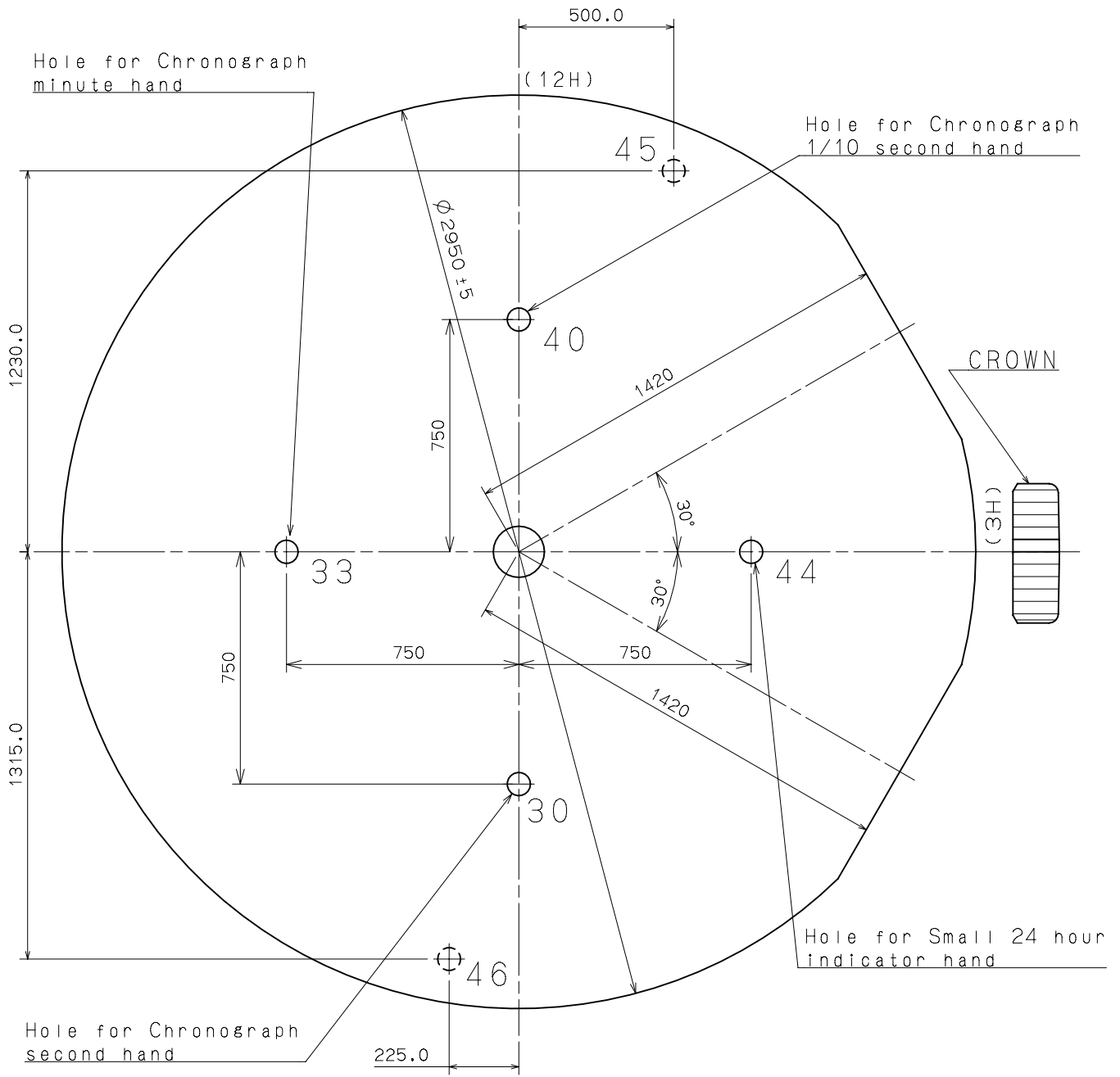

	TYPE M	TYPE L
A	40	85

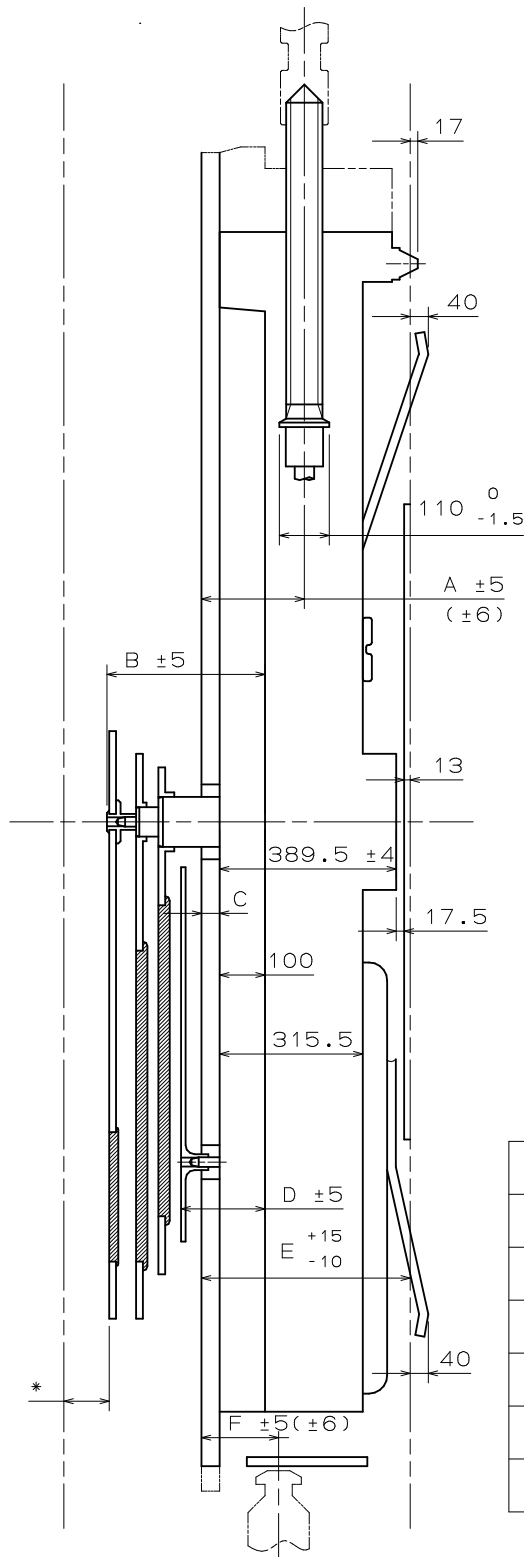

	TYPE M	TYPE L
A	227	272
B	343	388
C	40	85
D	185	230
E	460	505
F	170	215

*Acrylic Glass 50

*Mineral Glass 40

Unit : 1=1/100mm

Version : 1

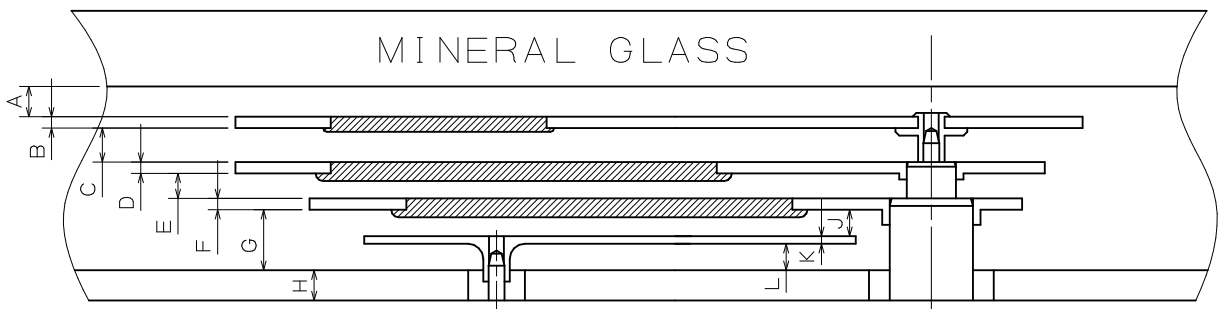
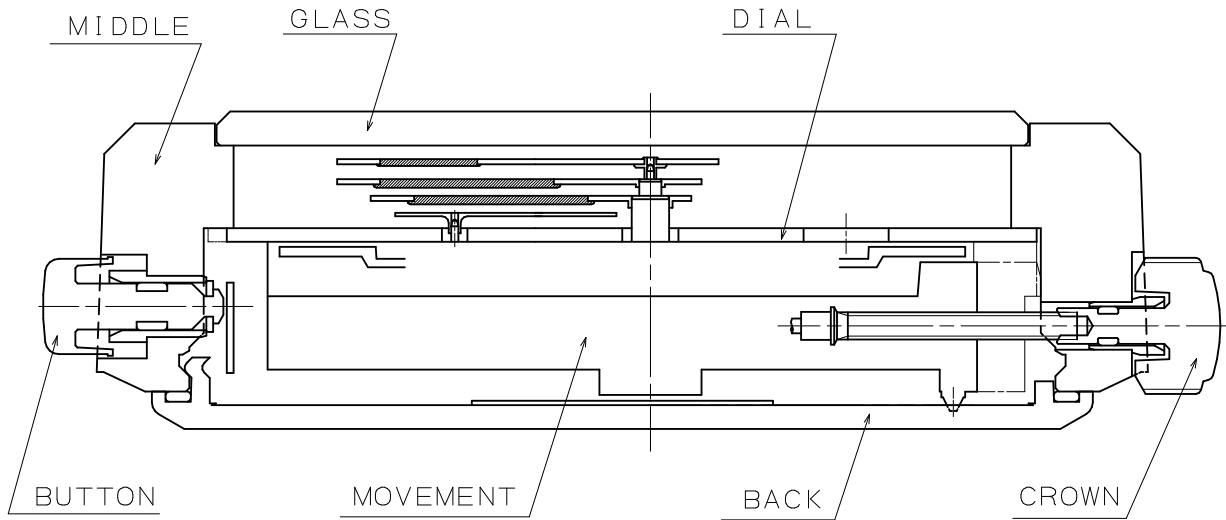

	TYPE M	TYPE L
A	40	40
B	15	15
C	45	45
D	15	15
E	33	33
F	15	15
G	80	80
H	40	85
J	35	35
K	10	10
L	35	35

SECOND

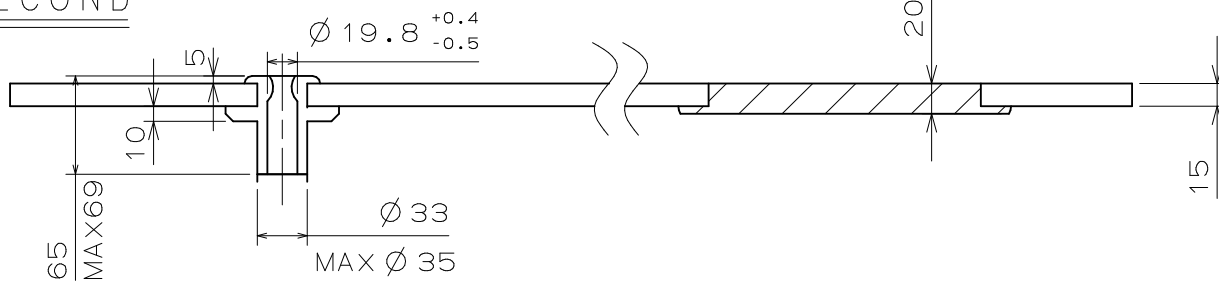

MINUTE

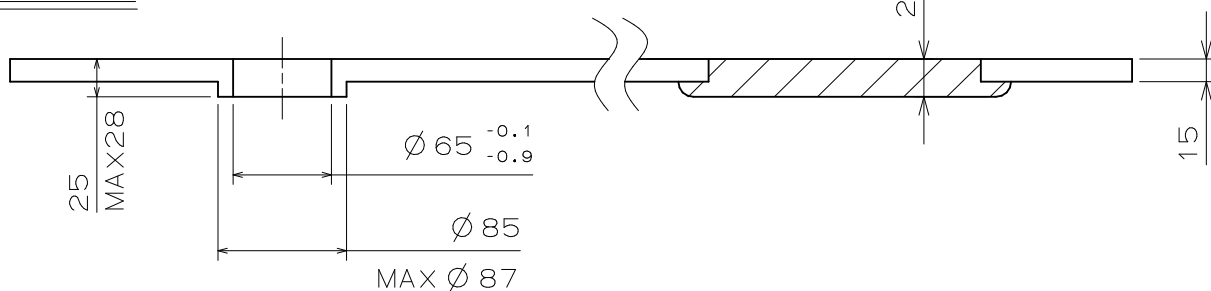

HOUR

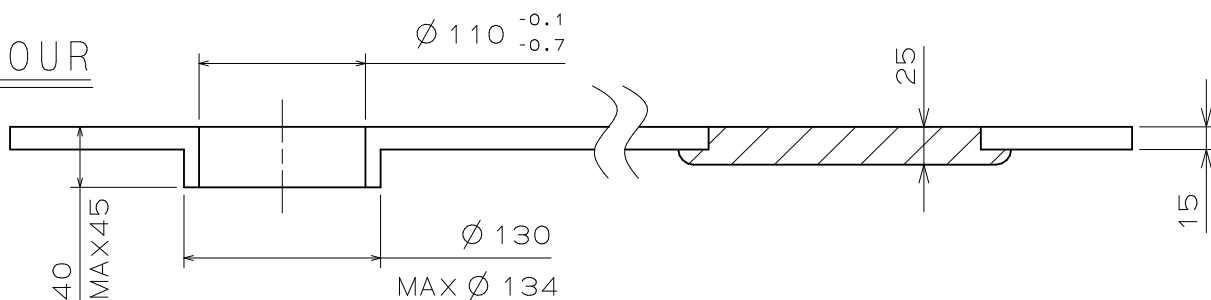

CHRONO

