

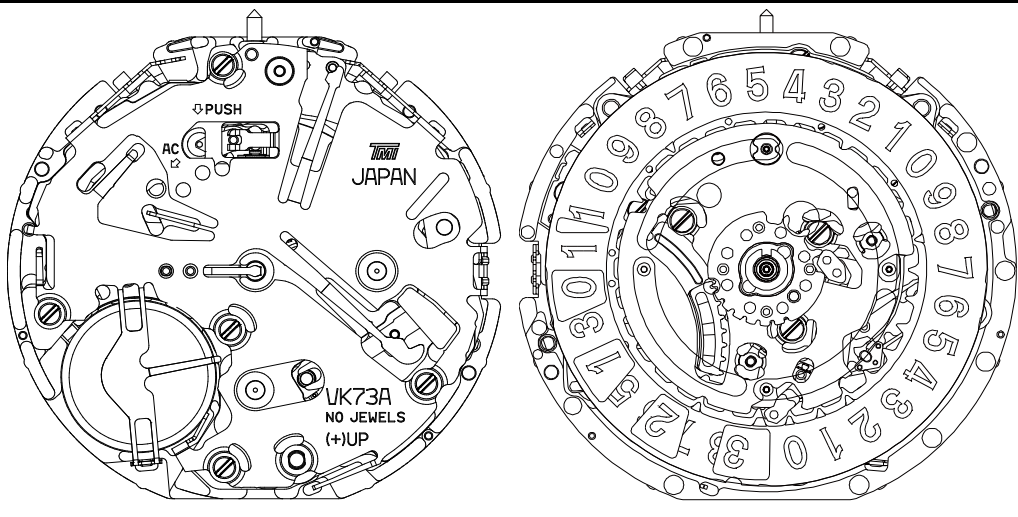



**TECHNICAL GUIDE
&
PARTS CATALOGUE**

Cal.VK73A



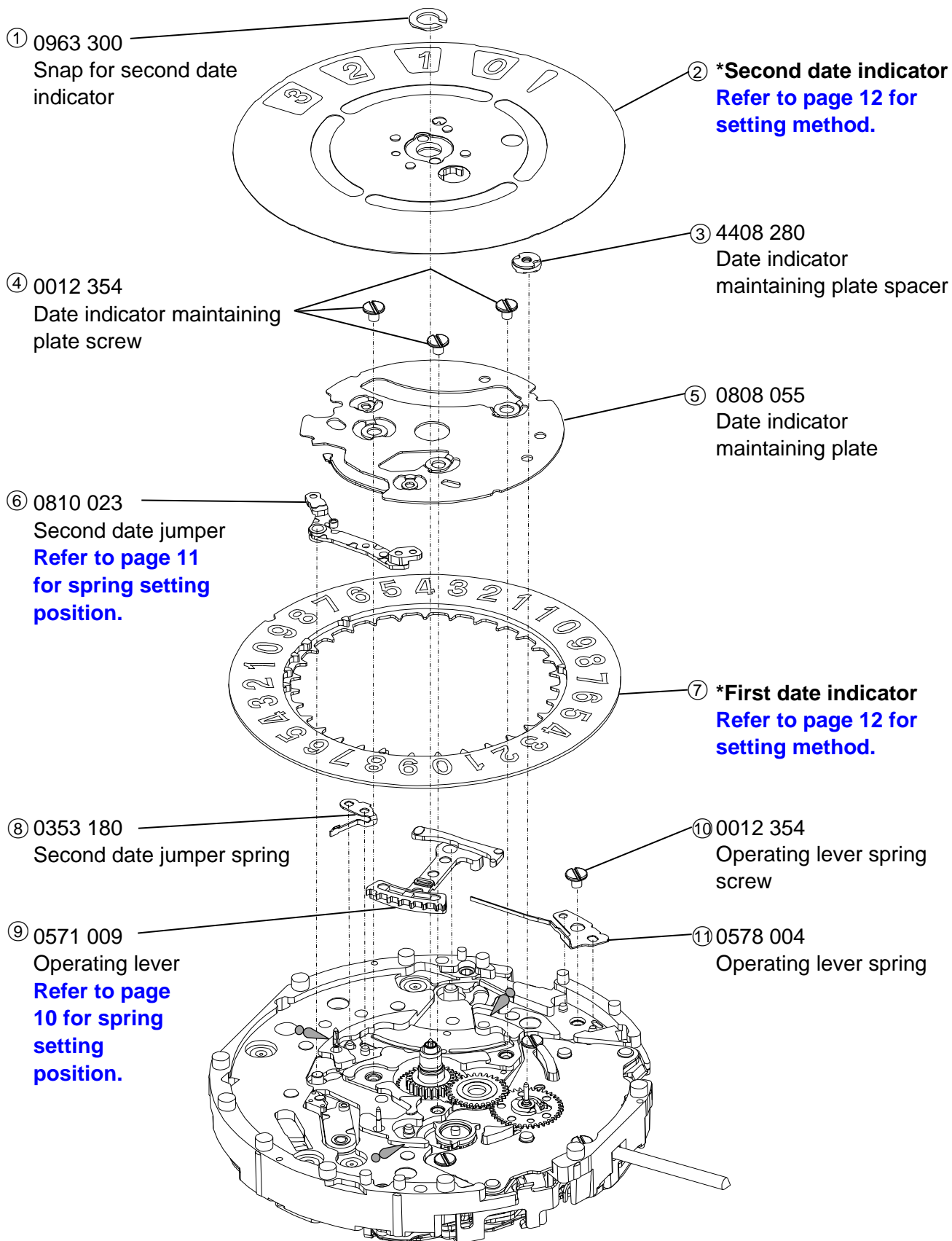

ANALOGUE QUARTZ

Cal. No.		VK73A
Item		
Movement		
Movement size	Outside diameter	φ30.80 mm × 29.10 mm (3H - 9H)
	Casing diameter	φ29.00 mm
	Total height	5.90 mm
Time indication	2 hands (Hour, Minute)	
	Small second hand (6H)	
	Date calendar (Big date)	
	Chronograph (1/5 center second, 60 Minutes (9H))	
	24 hour indicator (3H)	
Driving system	Two pole stepping motor Step motor 2 pieces	
Additional mechanism	Date display with quick correction Electronic circuit reset switch Time setting with stop-second	
Accuracy	Less than ± 20 seconds : Monthly rate at normal temperature range	
Battery	SR936SW (Silver oxide battery) Battery life is approximately 3 years (60 minutes chronograph operation per day)	
Measuring gate by quartz tester	Use 10 second gate *Set the winding stem with crown at the normal position	
Antimagnetic	≥ 1600 A/m	
Jewels	0 Jewel	





Disassembling procedures Figs. ① → ⑥9 Reassembling procedures Figs. ⑥9 → ①	Lubricating : Types of oil	Oil quantity
	 Moebius 9010  Moebius 9030	 NORMAL QUANTITY  SUFFICIENT QUANTITY

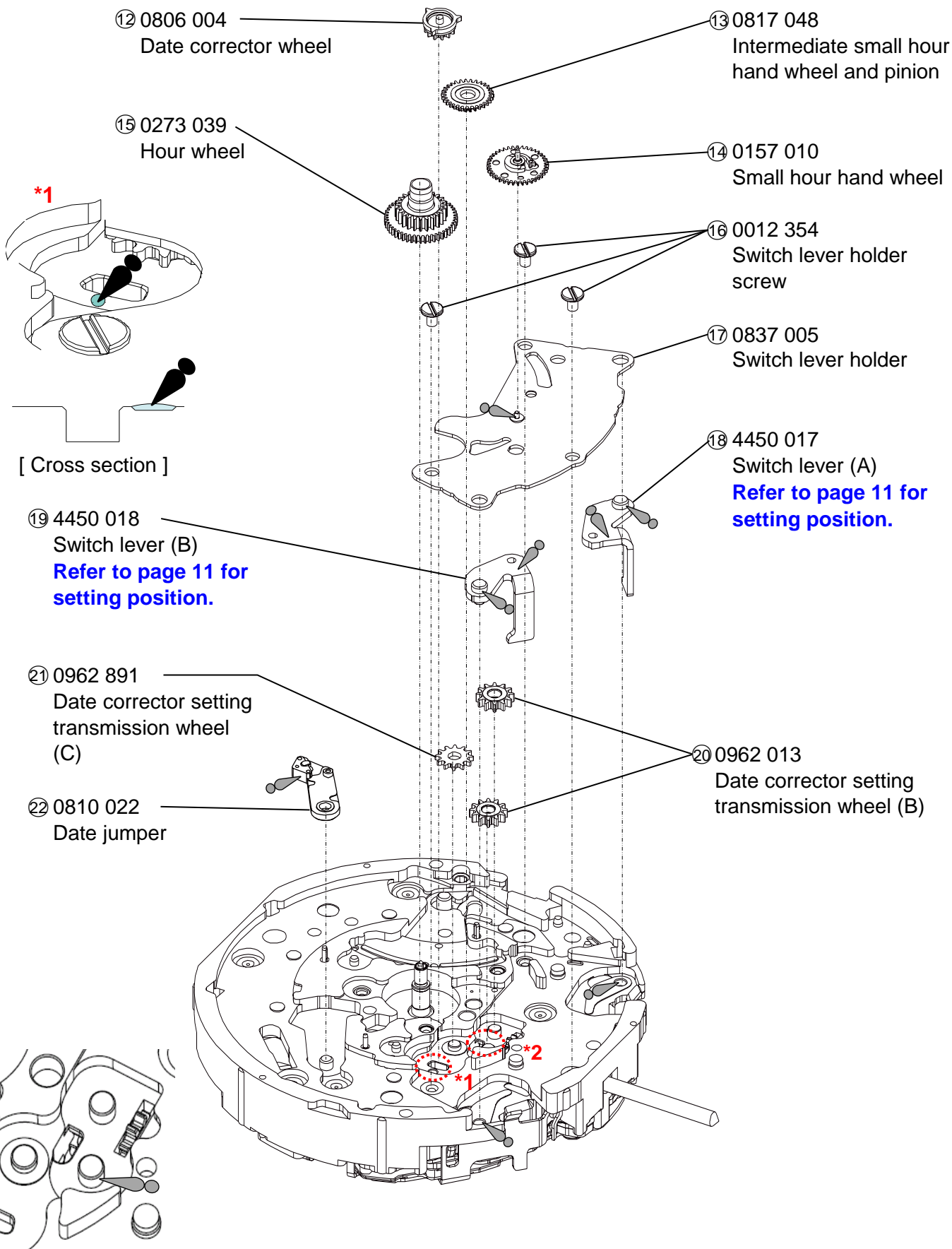

*Refer to page 7 for each parts code.

Disassembling procedures Figs. ① → ⑥9 Reassembling procedures Figs. ⑥9 → ①	Lubricating : Types of oil	Oil quantity
	 Moebius 9010  Moebius 9030	 NORMAL QUANTITY  SUFFICIENT QUANTITY





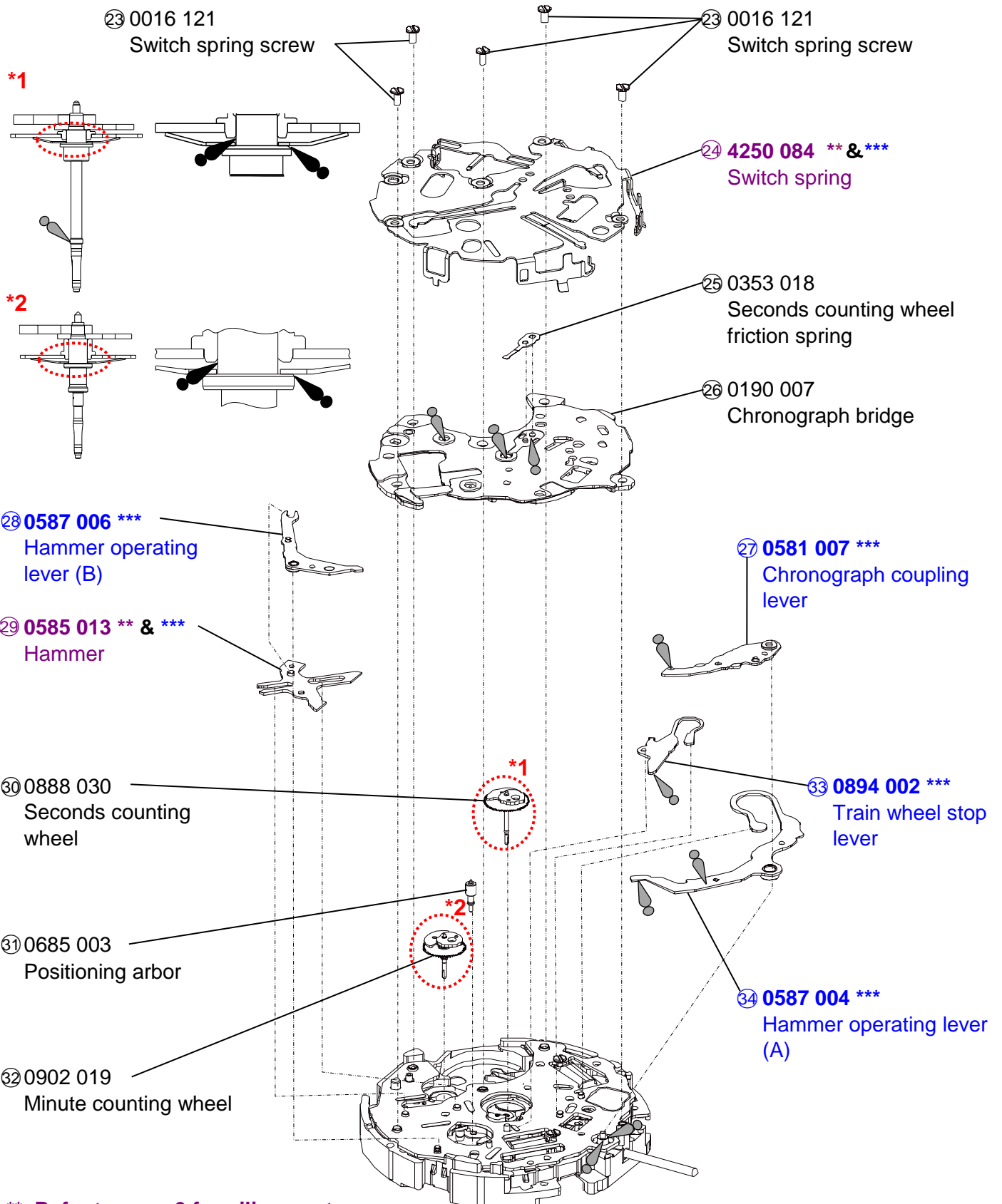

Disassembling procedures Figs. ① → ⑥9	Lubricating : Types of oil	Oil quantity
Reassembling procedures Figs. ⑥9 → ①	 Moebius 9010  Moebius 9030	 NORMAL QUANTITY  SUFFICIENT QUANTITY



** Refer to page 9 for oiling spot.



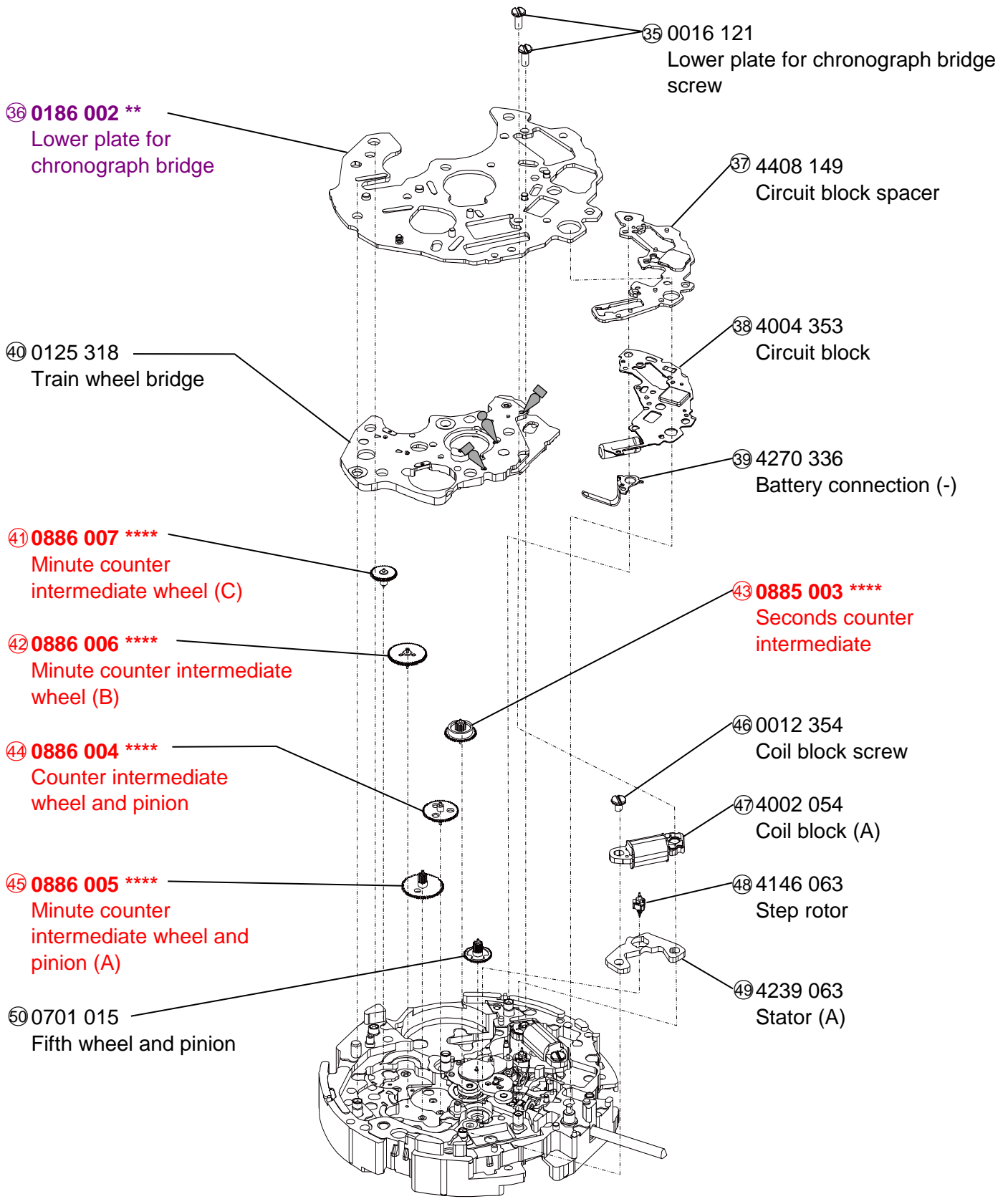

*** Refer to page 10 for spring setting position.

Disassembling procedures Figs. ① → ⑥9	Lubricating : Types of oil	Oil quantity
Reassembling procedures Figs. ⑥9 → ①	 Moebius 9010  Moebius 9030	 NORMAL QUANTITY  SUFFICIENT QUANTITY



** Refer to page 9 for oiling spot.

**** Refer to page 8 for assembling of chronograph wheel.

Disassembling procedures Figs. ① → ⑥9	Lubricating : Types of oil	Oil quantity
Reassembling procedures Figs. ⑥9 → ①	 Moebius 9010  Moebius 9030	 NORMAL QUANTITY  SUFFICIENT QUANTITY

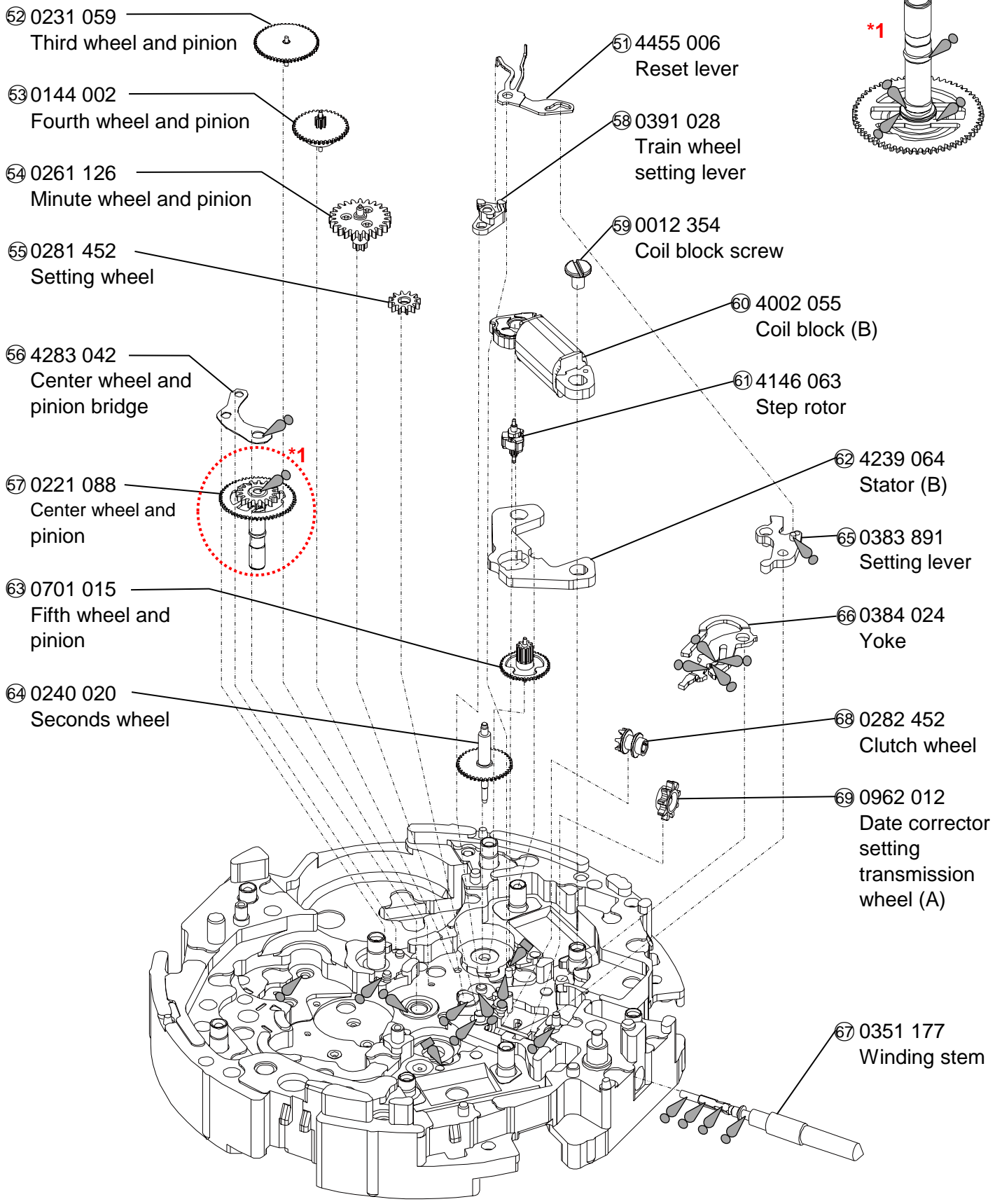

Remarks :

O Date indicator

Part code		Position of crown	Position of Date frame	Color of figure	Color of background
First date indicator	Second date indicator				
0878 338	0148 076	3H	12H	Black	White

*** All parts code are subject to change without notice.**

1. Detailed assembling of chronograph wheel

[NOTE]

There is a mark on parts. Parts are set in order of the mark as shown in the table below.



Mark	Parts name
B	④⑤ Minute counter intermediate wheel and pinion (A)
C	④④ Counter intermediate wheel and pinion
Nil	④③ Seconds counter intermediate wheel and pinion
F	④② Minute counter intermediate wheel (B)
G	④① Minute counter intermediate wheel (C)

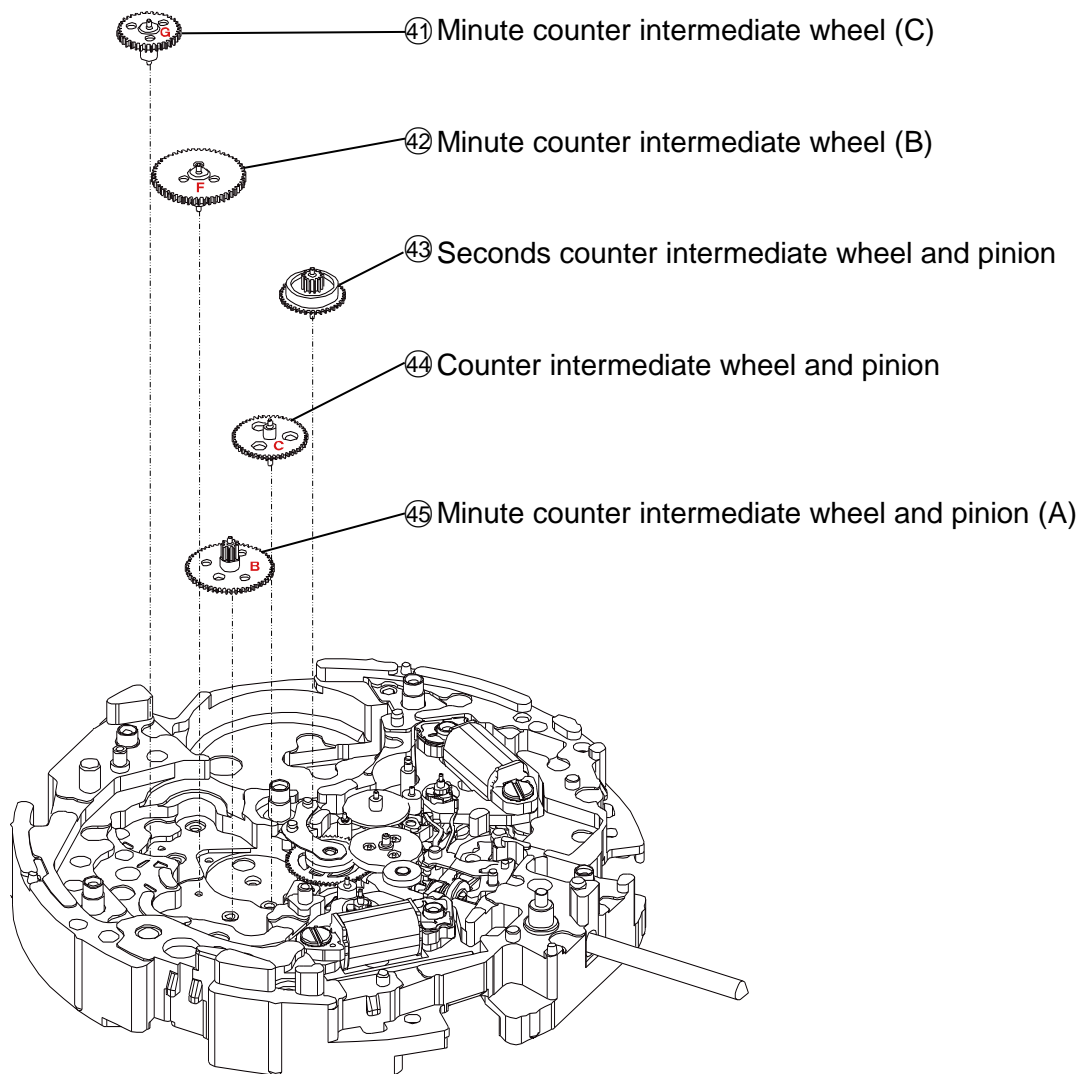

*Mark positions, and sizes, etc. are different.

Lubricating : Types of oil		Oil quantity	
	Moebius 9010		NORMAL QUANTITY
	S-6		SUFFICIENT QUANTITY

2.Oiling spot

⑳ Hammer

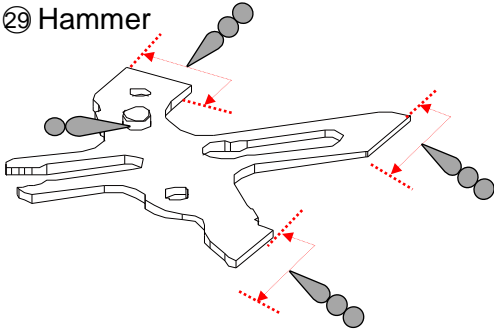

There must be oil within the range of the arrow.

㉑ Lower plate for chronograph bridge

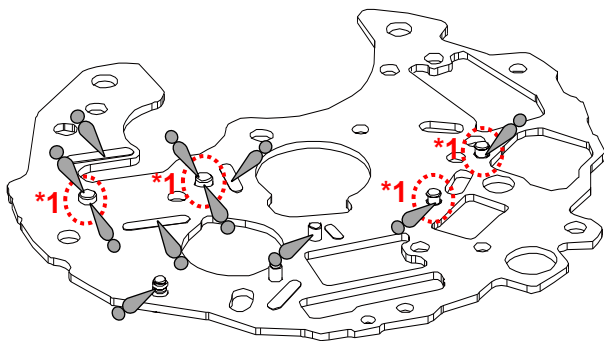

Note

***1:** Oiling should be done on the pointed spot of marked place.

㉒ Switch spring

*Oiling spot and spring setting position.

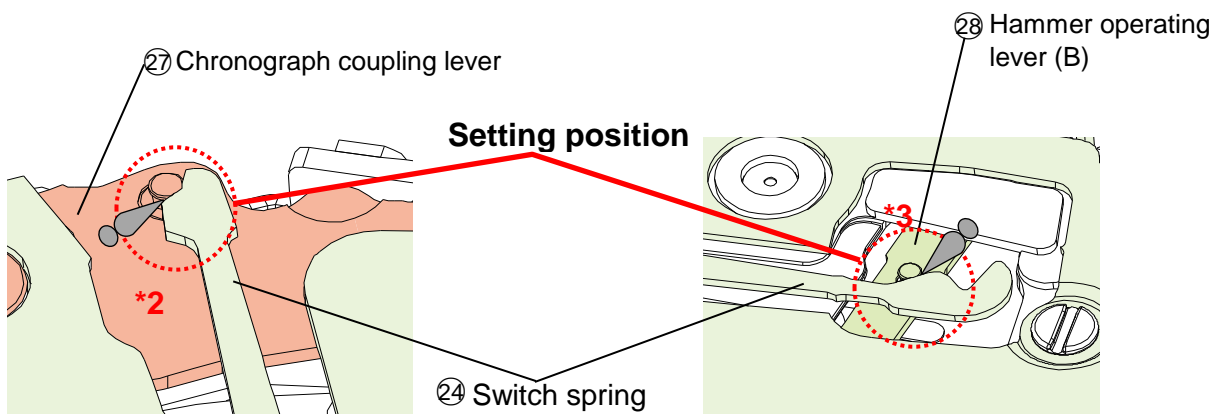
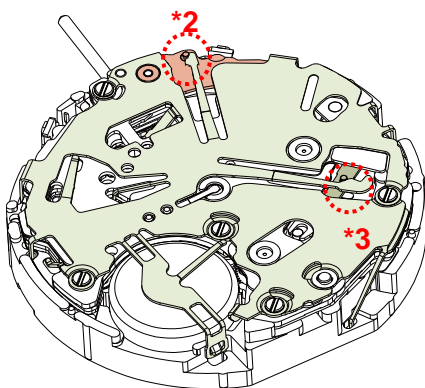

***Oiling should be done on the contact spot of the spring and the pin.**

3.Spring setting position

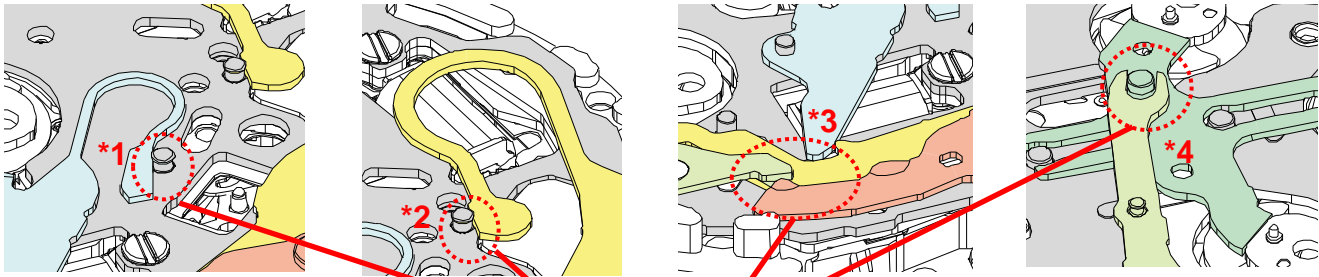
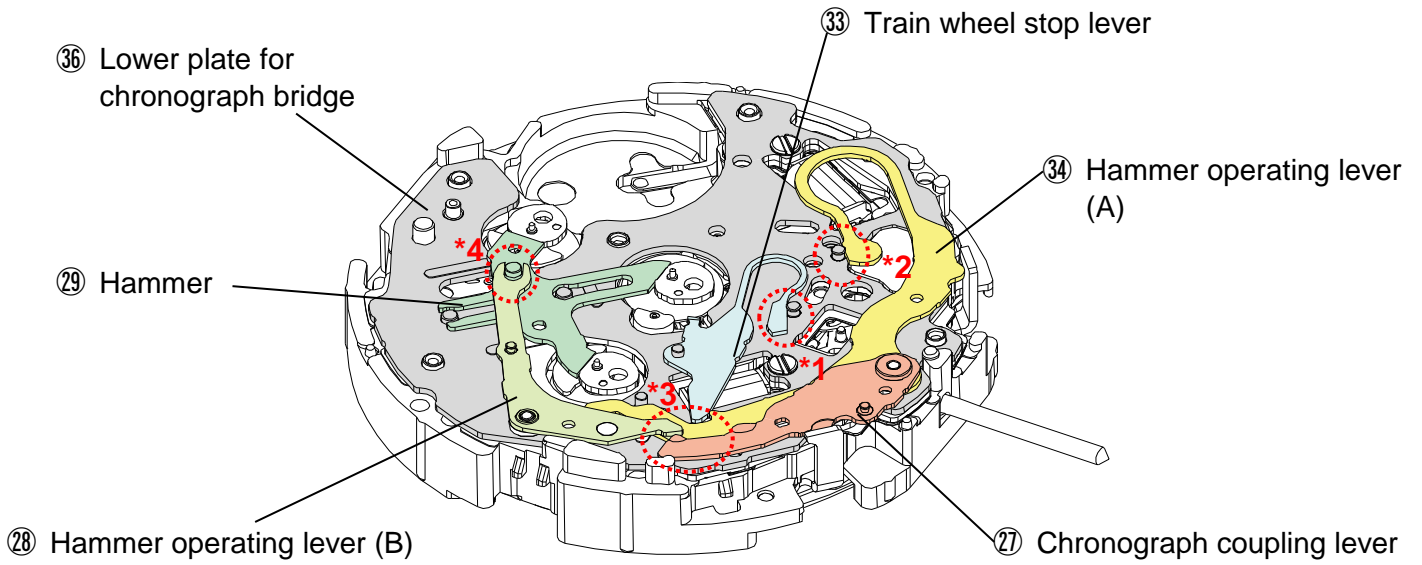

Setting position

⑨ Operating lever ①① Operating lever spring

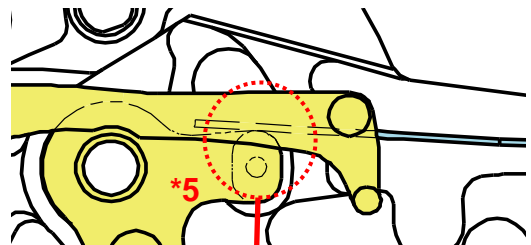
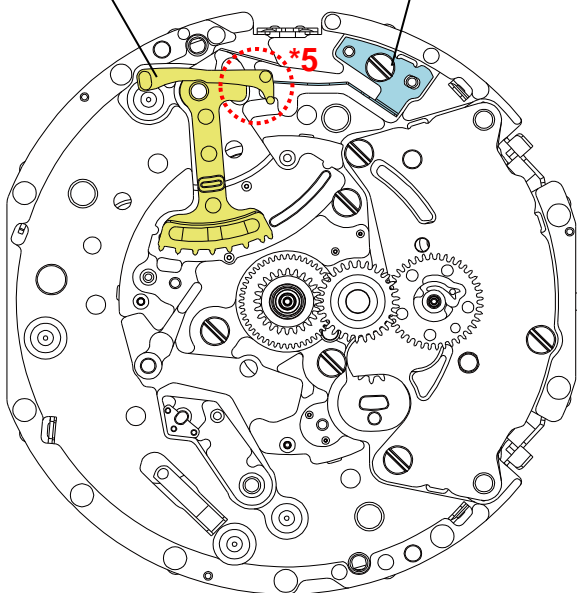

Setting position

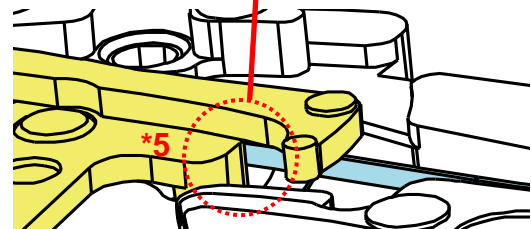

⑧ Second date jumper spring

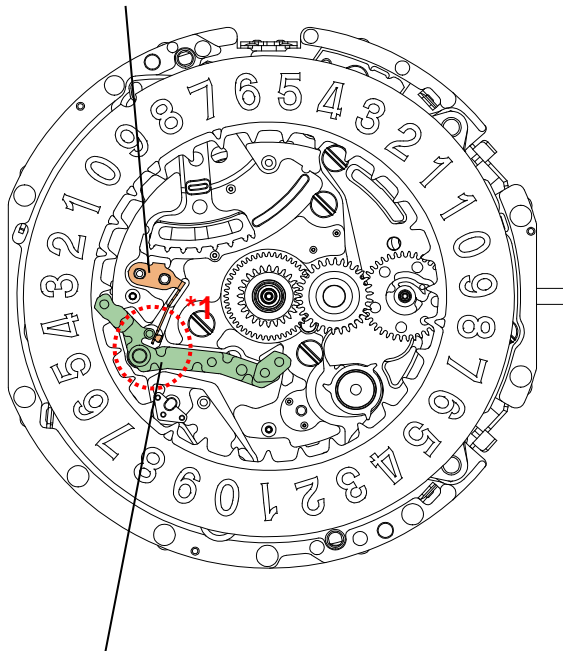

⑥ Second date jumper

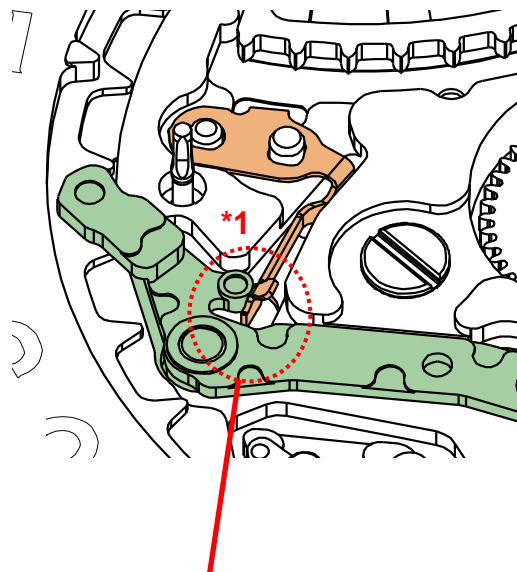

Setting position

4. Switch lever (A) and (B) setting position

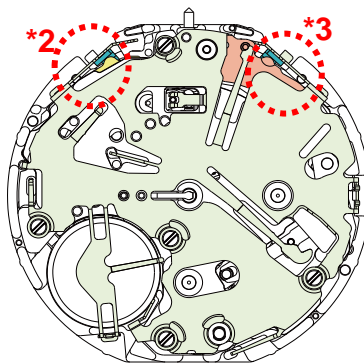

Enlarged view

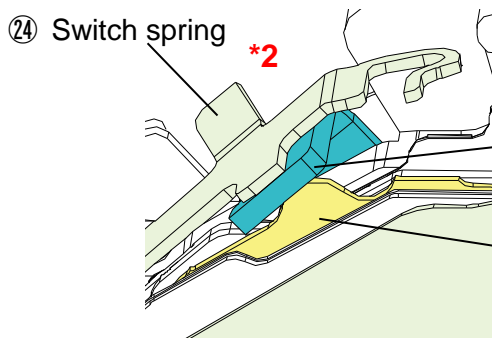

⑲ Switch lever (B)
⑩ Switch lever (A)
③④ Hammer operating lever (A)
⑲ Chronograph coupling lever

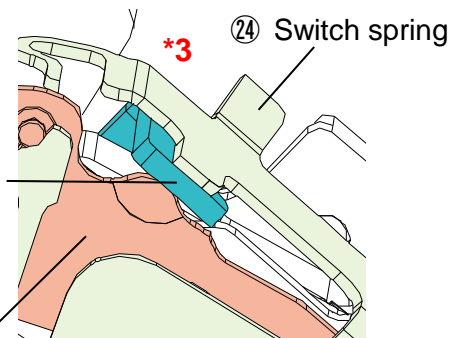

Switch lever (B) is set between the switch spring and hammer operating lever (A) .

Switch lever (A) is set between the switch spring and chronograph coupling lever.

5.Date indicator setting Method

1) First date indicator setting.

Set the hollow of the first date indicator align with the pillar of the main plate at 11H position.
(Date display at <__5>)

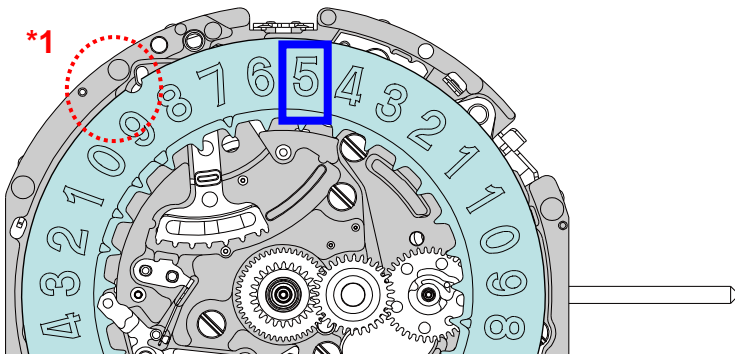

Pillar in main plate at 11 o'clock position

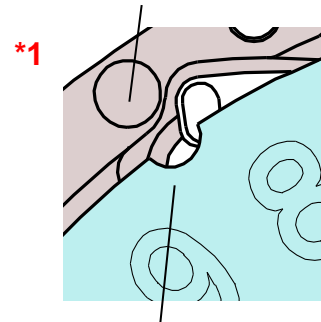

Hollow in first date indicator

2) Second date indicator setting.

2)-1. The wheel of the second date indicator is engaged with the wheel of operating lever as shown in figure below. (Date display at <__5>)

2)-2. Pull out crown to first click and turn it by clockwise to set the data.
(Date display : <05>day changes to <10>day)

Note : If date display does not change to <10>day, remove the second date indicator from movement, and turn crown by clockwise until the first date indicator back to 1)(*1) situation, then do 2) again.

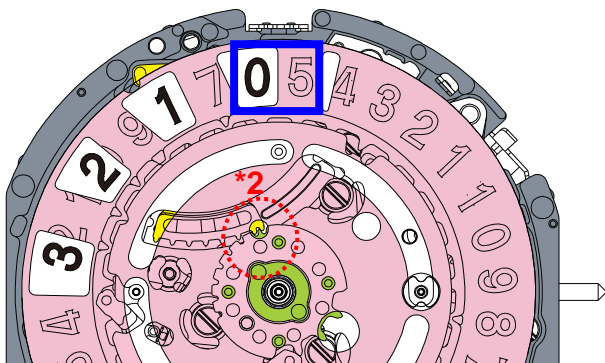

Wheel of operating lever

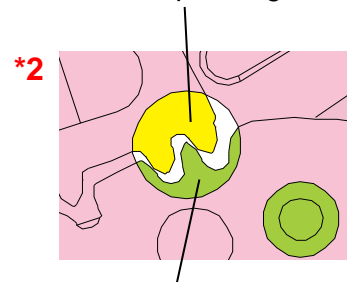

Wheel of second date indicator

Pull out crown to first click and turn it by clockwise to set the data.
(Date display : <05>day → <10>day)

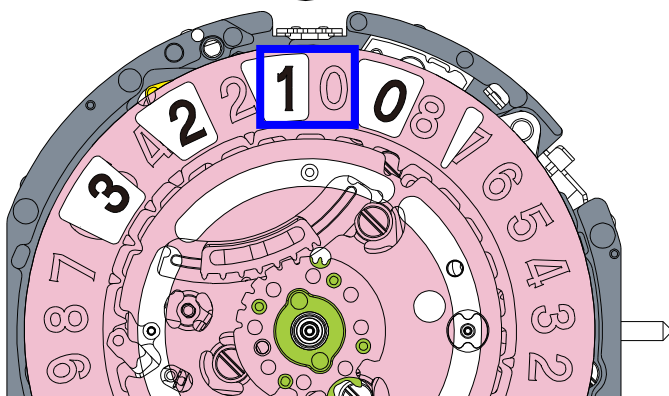

3) When the date indicators were set properly, abnormal date does not display.

For example) <00>day, <32>day, <33>day, <34>day <39>day.

6.To remove the winding stem

- 1) Set the winding stem to normal position.
- 2) Pull out the winding stem while pushing "A".

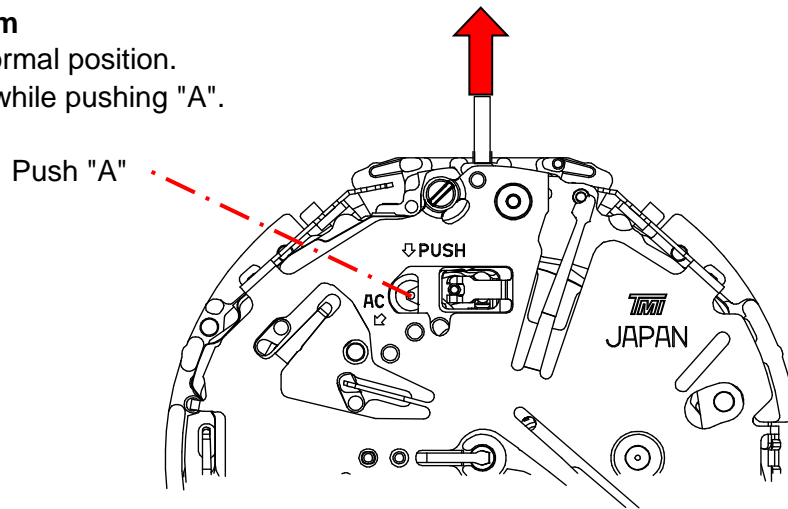

7.To remove or install the battery

- 1) Remove the hook of the switch spring's battery clamp.
- 2) Insert the battery sideways, and have the hook of the switch spring's battery clamp catch the main plate.

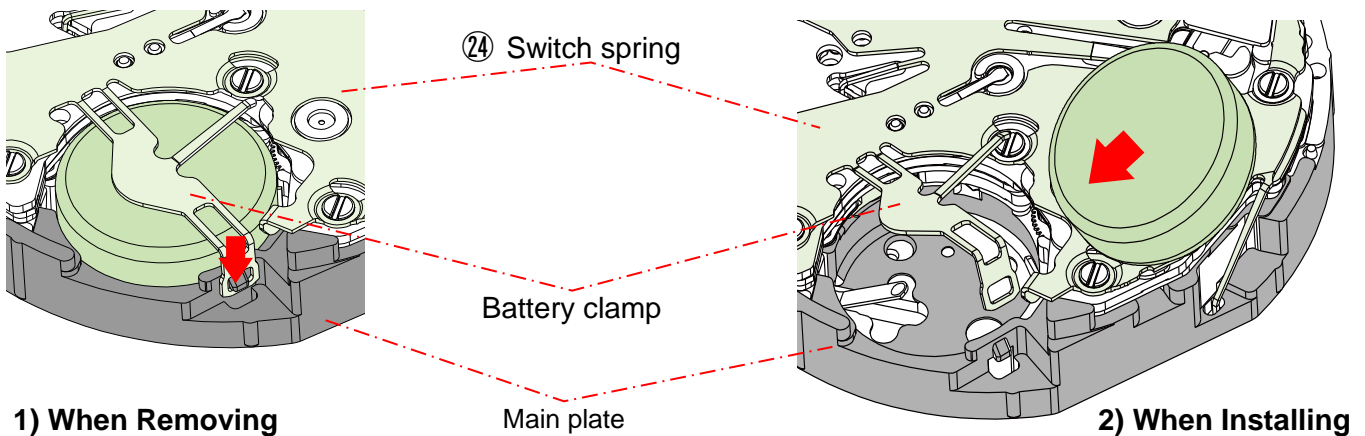

8.Remarks on installing the battery

- 1) After the battery is replaced with a new one, or after the battery is reinstalled following the repairing procedures, be sure to touch the AC terminal of circuit block and the switch spring with conductive tweezers to reset the circuit as illustrated.

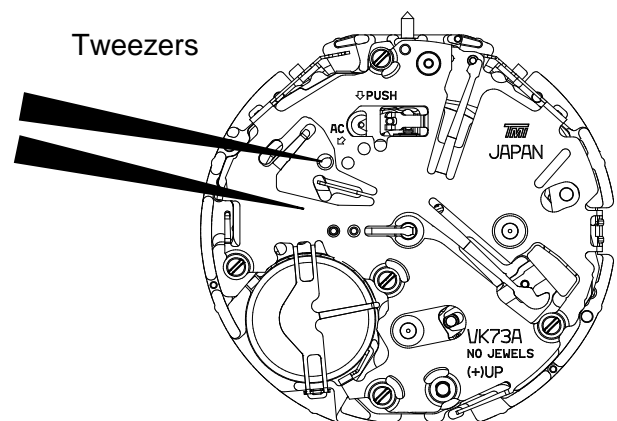

9.How to install the hands

Place the movement directly on a flat metal plate, or something alike to install the hands.

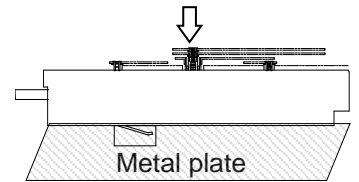

[Note: Second / Minute chronograph hands setting]

- (1) Push button (A) (Chronograph start)
- (2) Push button (A) (Chronograph stop)
- (3) Push button (B) (Chronograph reset)
- (4) After (1)-(3), Install the chronograph hands as shown in the table below.

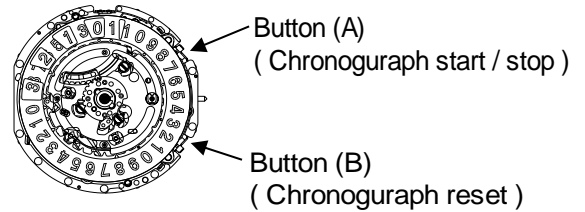

Second chronograph	"12" o'clock (center)
Minute chronograph	"60" minute (9H)

***Do not reuse the chronograph hands once detached. Please change and use new hands.**

[Note: To install 24 hour hand]

Before installing 24 hour hand, pull out the crown to the second click position and rotate it clockwise, until changed to the next date then install the 24 hour hand.

10.How to check correct hands attachment

The hand's top surface should be set parallel with the axis tip , as shown below.

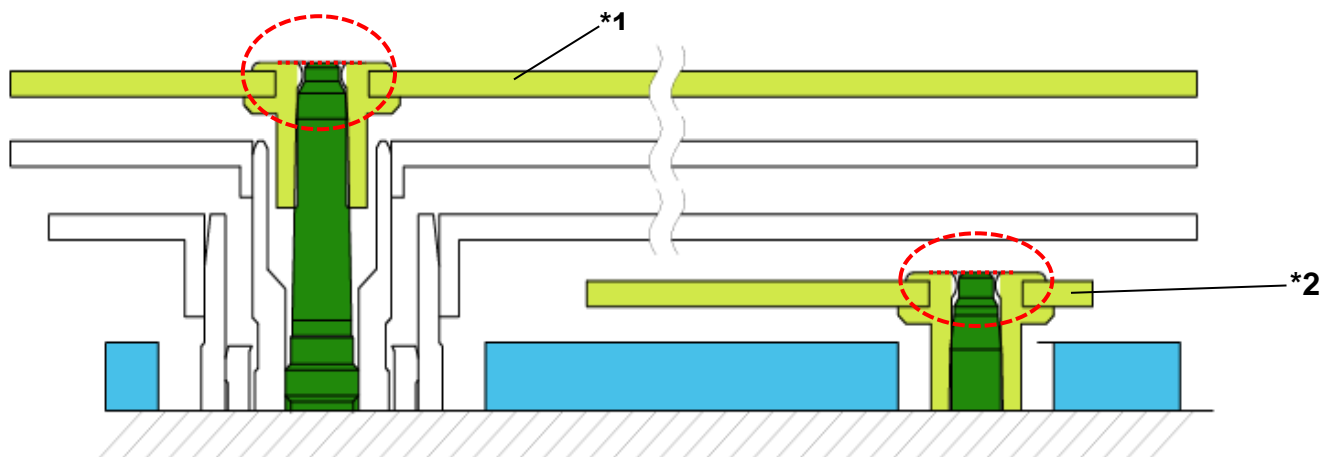

Application hands

- *1: Second chronograph hand
- *2: Minute chronograph hand and Small second hand and 24 hour hand

DISPLAY AND CROWN / BUTTON OPERATION

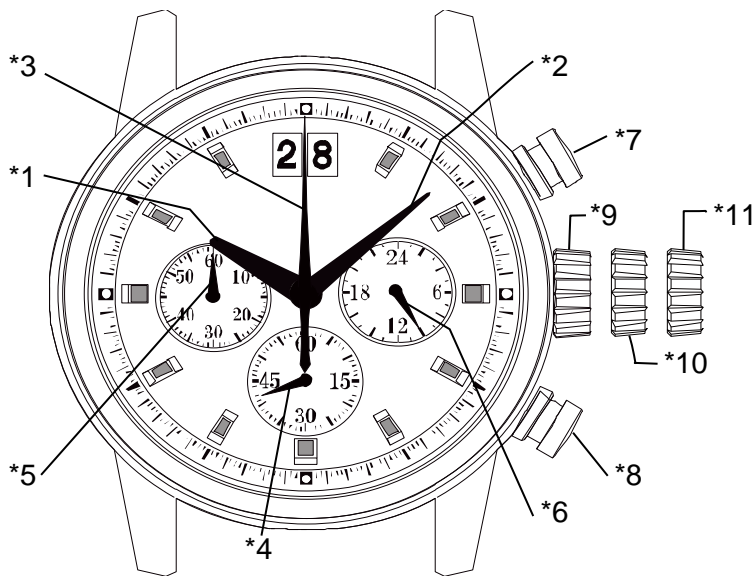

Note

*1:	Hour hand
*2:	Minute hand
*3:	Chronograph second hand
*4:	Small second hand
*5:	Chronograph minute hand (60 minute)
*6:	24 hour hand
*7:	Button (A) (START / STOP)
*8:	Button (B) (RESET)
*9:	Crown at normal position
*10:	Crown at first position (Date setting)
*11:	Crown at second position (Time setting)

1.How to set the time

- 1) Pull out the crown to the second click position.
- 2) Turn the crown to set hour and minute hands.
(Check that AM / PM is set correctly.)
- 3) Push the crown back into the normal position.

[Note]

If the crown is pulled to the second position while the chronograph is started, the chronograph hands will continue to move. This is not a malfunction.

2.How to set the date

- 1) Pull out the crown to the first click position.
- 2) Turn the crown clockwise for date setting.
*Do not set the date between 9:00 P.M. and 3:00 A.M. as this will cause a malfunction.

[Note]

When the crown is turned with excess strength, the date may show improperly.

By turning the crown slowly, this phenomenon will be recovered to a normal date indication.

- 3) Push the crown back into the normal position.

3.How to reset (after battery change)

It is possible to reset by the following two methods.

- Method 1 {
- 1) Set the crown to the normal position.
 - 2) Touch the AC terminal of circuit block and the switch spring with conductive tweezers to reset the circuit.
 - 3) The small second hand will move at two-second interval for 10 seconds.

- Method 2 {
- 1) Pull out the crown to the second click position.
 - 2) Press the button B for two seconds and release the button.
 - 3) Push the crown back to the normal position.
 - 4) The small second hand will move at two-second interval for 10 seconds.

* If the crown is operated within this 10 seconds, the two-second interval movement will not activate.

[Note]

It is not necessary to set the chronograph hands after the battery is exchanged.

If the chronograph hands position are incorrect, following below procedure all the chronograph hands will be reset to "0" position.

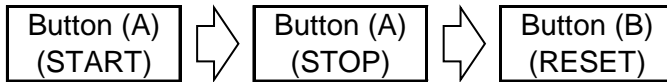

HOW TO USE THE CHRONOGRAPH

[Standard measurement]

Press the buttons in the following order : A → A → B
START → STOP (Finish) → RESET



(20 minutes 10 seconds)

- Press button (A) to start the chronograph.
The chronograph second hand will start moving.

- Press button (A) again to stop the chronograph.
The chronograph hands stop to indicate the elapsed time.

- Press button (B) to reset the chronograph.
All the chronograph hands will be reset to "0" position.

Note

The chronograph can measure up to 60 minutes.
The chronograph stops after a measurement for 60 minutes.
*Restart by pushing button (A).

During the chronograph operation, button (B) (reset) can be pushed. There is no problem with the function.

[Accumulated elapsed time measurement]

Press the buttons in the following order : A → A / A ... → A → B
START → STOP / RESTART → STOP → RESET

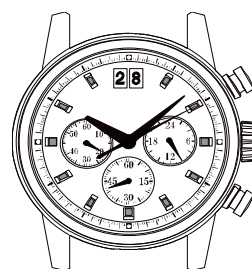
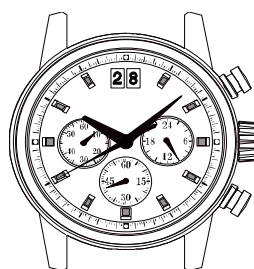

(8 minutes 40 seconds) (20 minutes 10 seconds)

*Restart and stop of the chronograph can be repeated as many times as necessary by pressing button (A).