

Watch Movement Specification and Drawing

Premium Mechanical Movement

NE88A

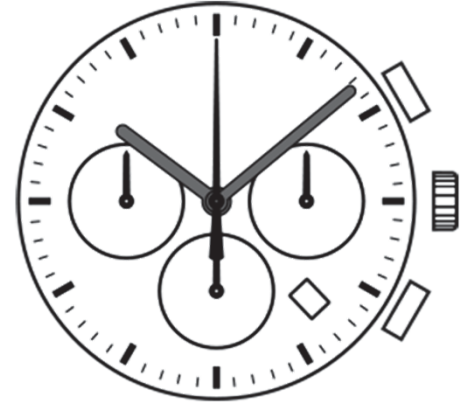

Movement Size: **12 1/2"**
 Diameter: **Φ28.60mm**
 Height: **7.62mm**

Items	Ver.	Items	Ver.
Specification	1		
Appearance	1		
Casing	1		
Hand Fitting	1		
Hand Setting Stem	1		
Dial	1		
Casing Ring	1		
Casing Clamp	1		
Movement Holder	1		
Assembly Plan	1		
Hands	1		

CAL.NE88A 12½ Ligne Mechanical Movement

Two Hands with 3 Eyes & Date

Center Chronograph Second Hand

Small Chronograph Minute & Hour Hands, Small Second Hand

1. FUNCTION

· Jewel	34 jewels
· Accuracy	-15 ~ +25 seconds / day (23 ± 2 °C)
· Regulation hands unbalance	Hour hand : Less than 1.50 μN·m (150 mg·mm)
	Minute hand : Less than 1.25 μN·m (125 mg·mm)
	Small second hand : Less than 0.05 μN·m (5 mg·mm)
	Small chronograph hour & minute hands : Less than 0.05 μN·m (5 mg·mm)
	Center chronograph second hand : Less than 0.20 μN·m (20 mg·mm)
	· The moment of inertia
	Center chronograph second hand : Less than 400 mg·mm ²
· Additional function	Manual winding
	Automatic winding with ball bearing
	Both winding with one way clutch
	Second hand stop mechanism
	Date display with quick date correction
	Center chronograph second
	Small chronograph minute (max. 30 minutes) and hour (max. 12 hours)

2. USE AND TEST CONDITION

· Vibration frequency	28,800 vibrations per hour
· Duration time	More than 45 hours (Under no chronograph function)
· Antimagnetic	≥ 4800 A / m (Direct current magnetic field)
· Test of accuracy	20 seconds (Duration of measurement)
· Casing	Non-corresponding with Diver's watch

*** All specifications are subject to change without notice.**

Appearance

NE88A

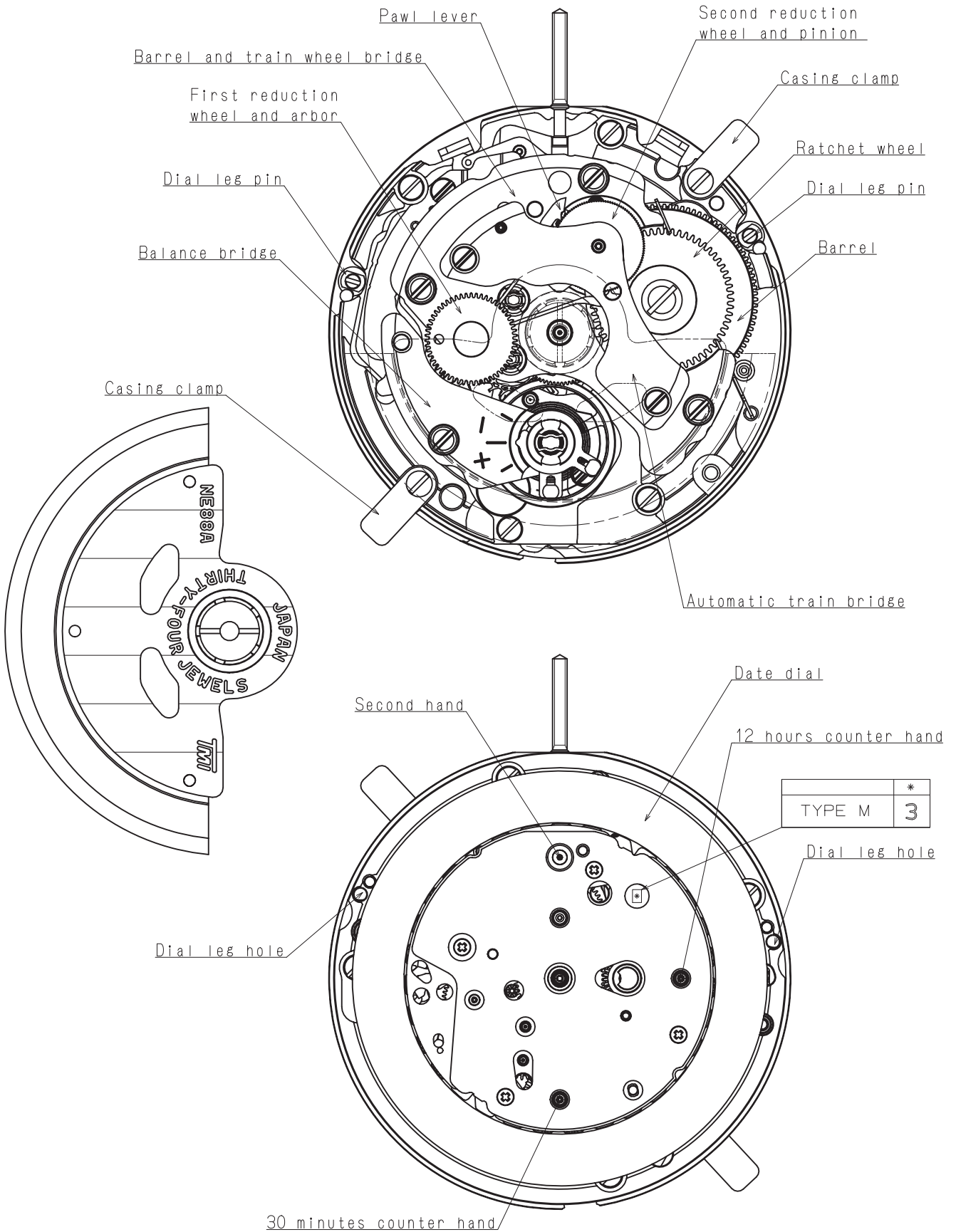

	*
TYPE M	3

Version : 1

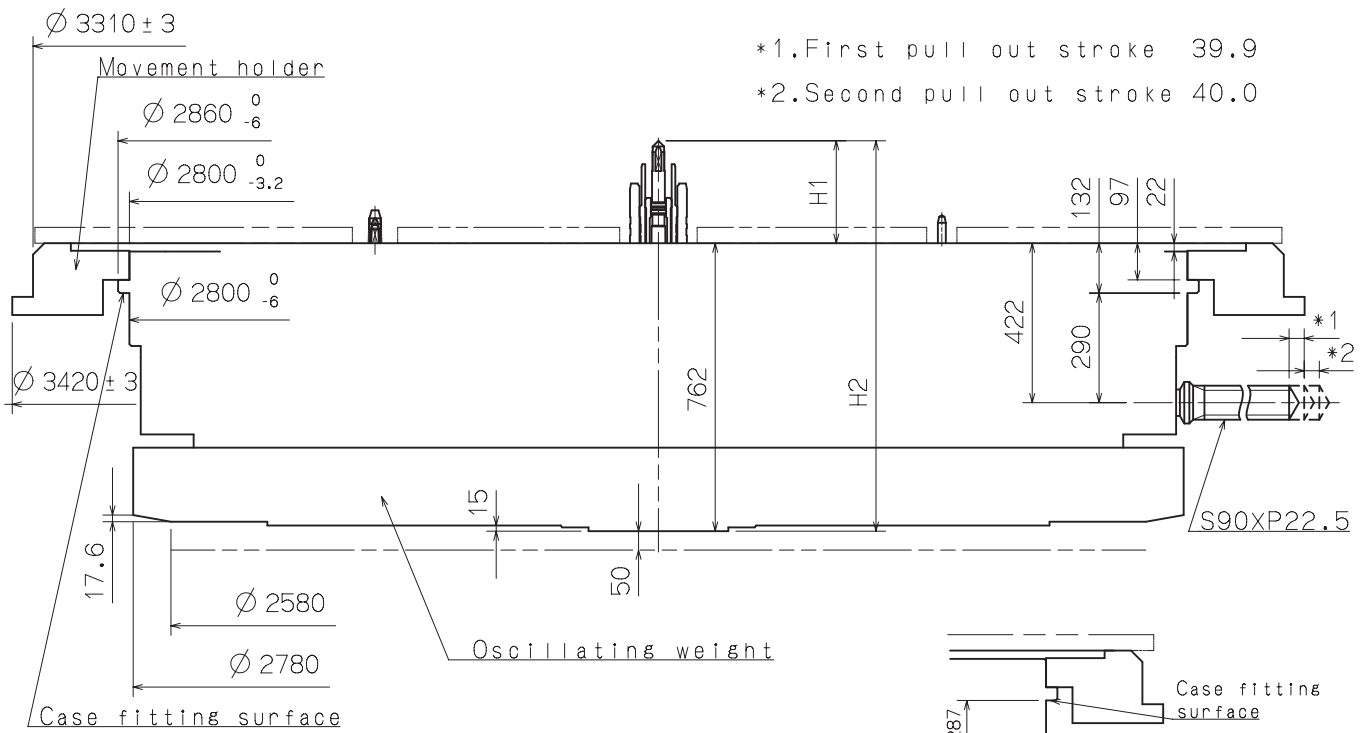

*1. First pull out stroke 39.9
 *2. Second pull out stroke 40.0

Center post 中心柱位		TYPE M 一般針高
Maximum height from main plate surface 與機芯平面的最大高度	H1	271.0
Total height incl. movement 機芯總高度	H2	1033.0

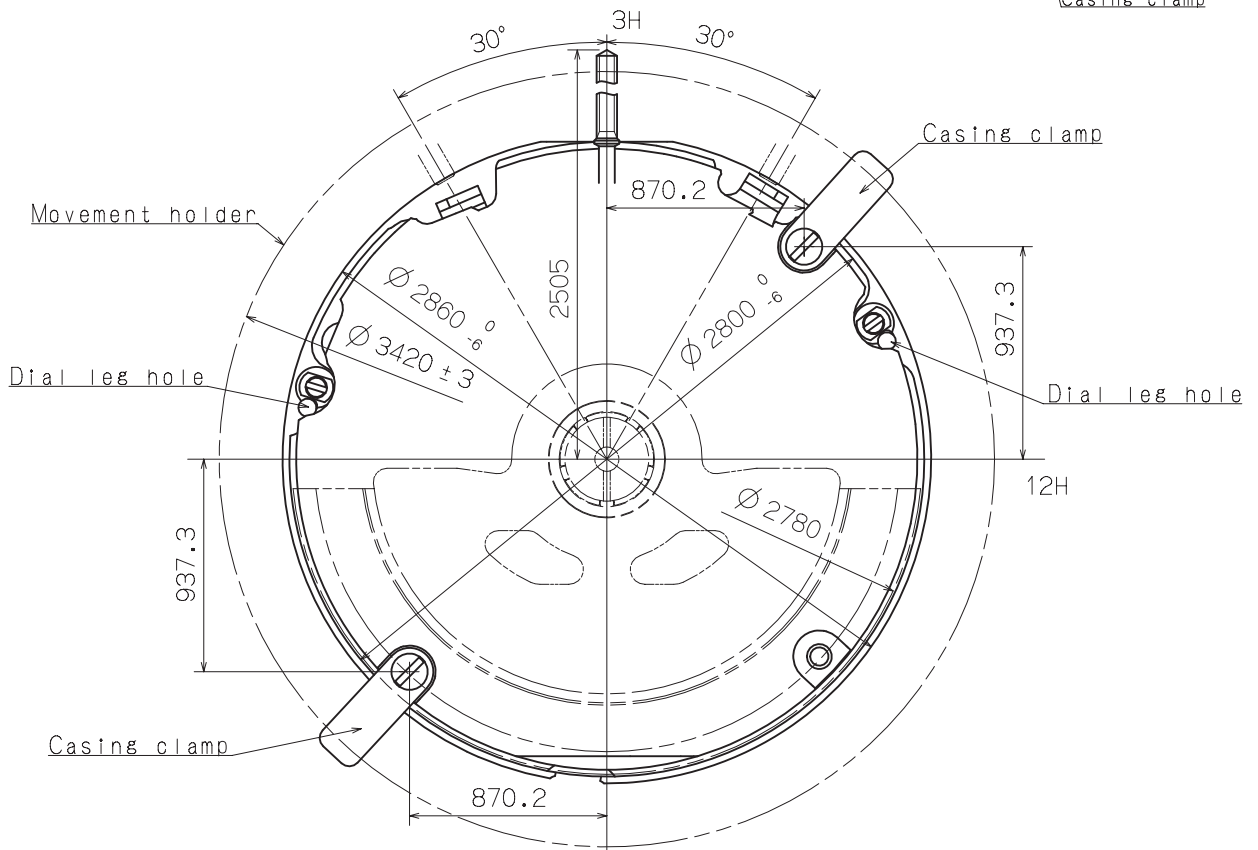

Hour hand unbalance $\leq 1.50\mu\text{N}\cdot\text{m}(150\text{mg}\cdot\text{mm})$ 12 hours counter hand unbalance $\leq 0.05\mu\text{N}\cdot\text{m}(5\text{mg}\cdot\text{mm})$
 Minute hand unbalance $\leq 1.25\mu\text{N}\cdot\text{m}(125\text{mg}\cdot\text{mm})$ 30 minutes counter hand unbalance $\leq 0.05\mu\text{N}\cdot\text{m}(5\text{mg}\cdot\text{mm})$
 60 seconds counter hand unbalance $\leq 0.20\mu\text{N}\cdot\text{m}(20\text{mg}\cdot\text{mm})$ Second hand unbalance $\leq 0.05\mu\text{N}\cdot\text{m}(5\text{mg}\cdot\text{mm})$

HOUR HAND FITTING
 Hour wheel 時針輪 : 0273 277

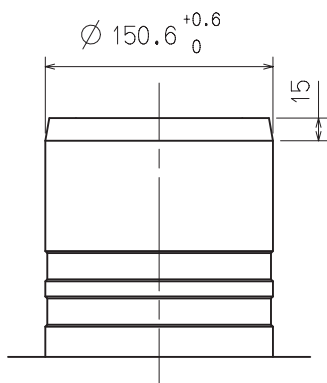

MINUTE HAND FITTING
 Center wheel 分針輪 : 0270 443

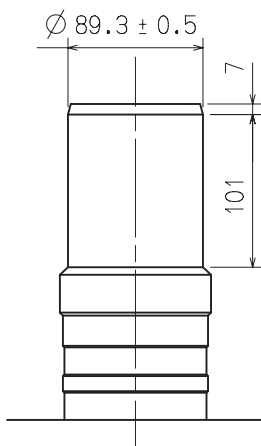

60 SECONDS COUNTER HAND FITTING
 Second counting wheel 計時秒針輪 : 0888 181

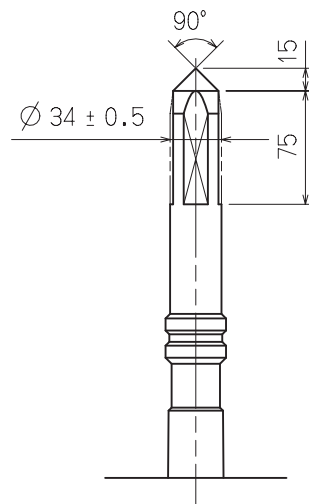

30 MINUTES COUNTER HAND FITTING
 12 HOURS COUNTER HAND FITTING
 Minute/hour counting wheel 計時分/時針輪 : 0902 184

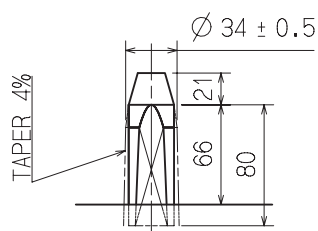

SECOND HAND FITTING
 Second wheel 秒針輪 : 0240 178

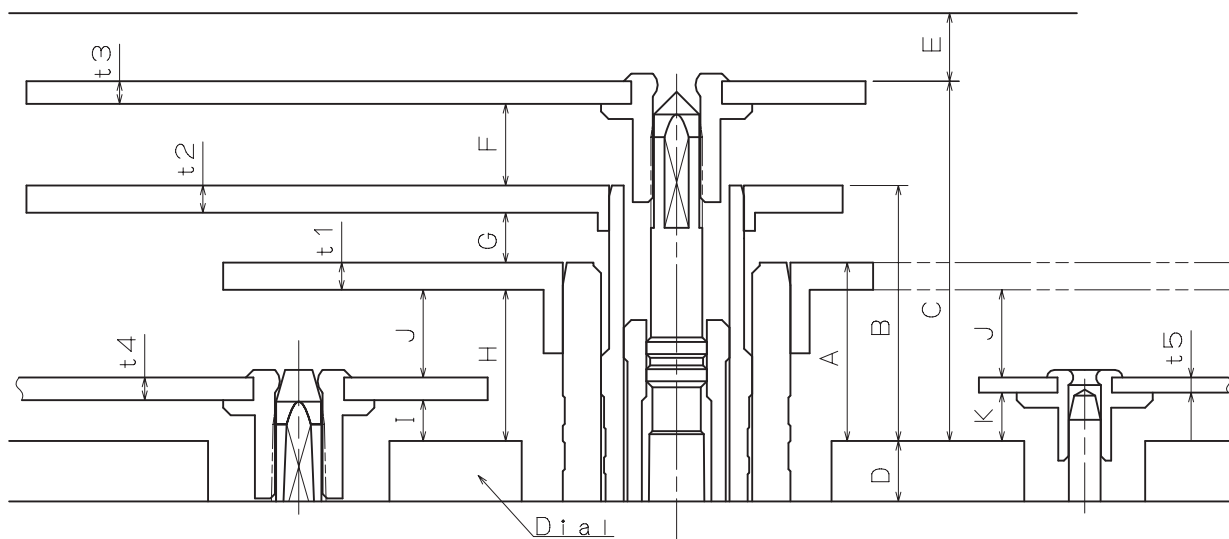
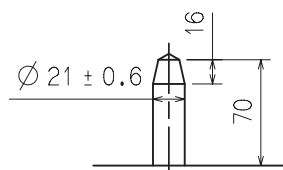

	A	B	C	D	E	F	G	H	I	J	K	t1	t2	t3	t4	t5
TYPE M 一般針高	118	169	238	40	45	54	33	100	27	58	32	18	18	15	15	10

Unit : 1=1/100mm

Version : 1

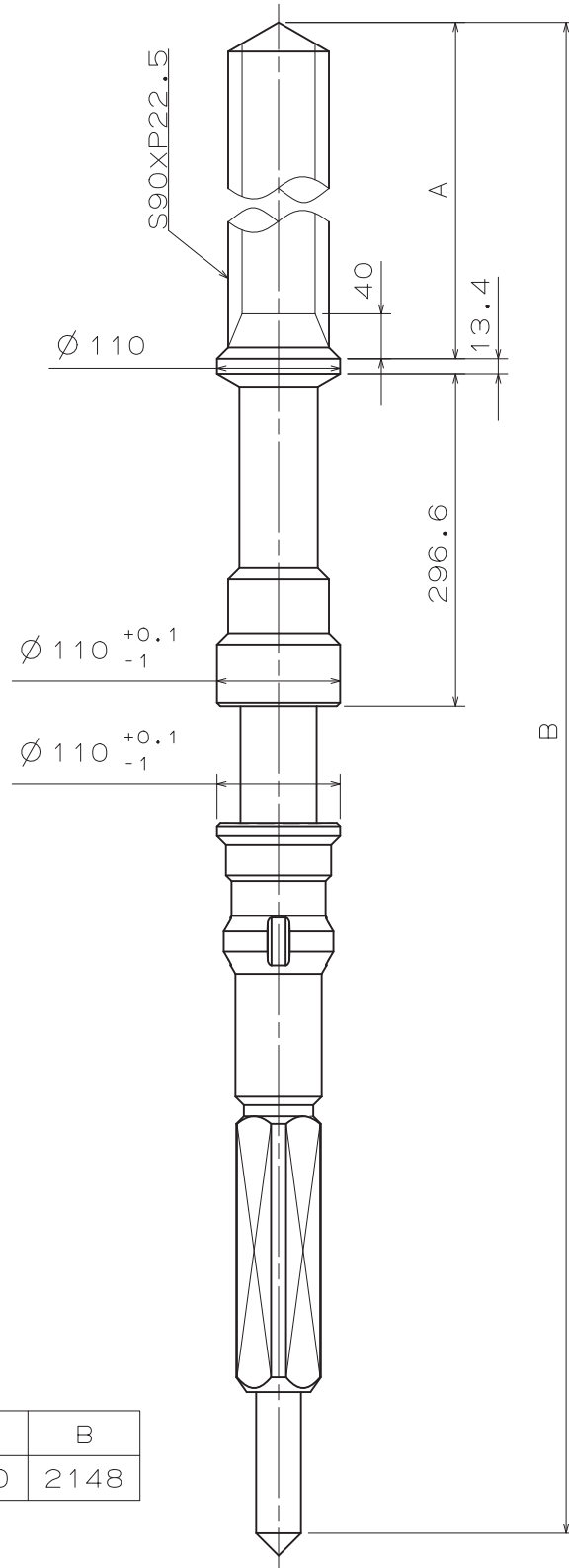

Part No.	A	B
0351 200	1100	2148

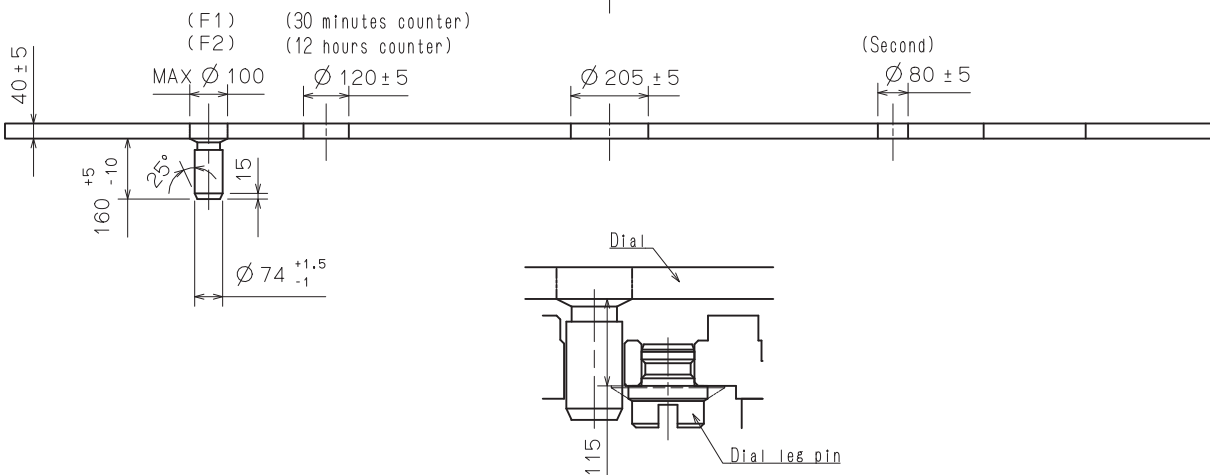
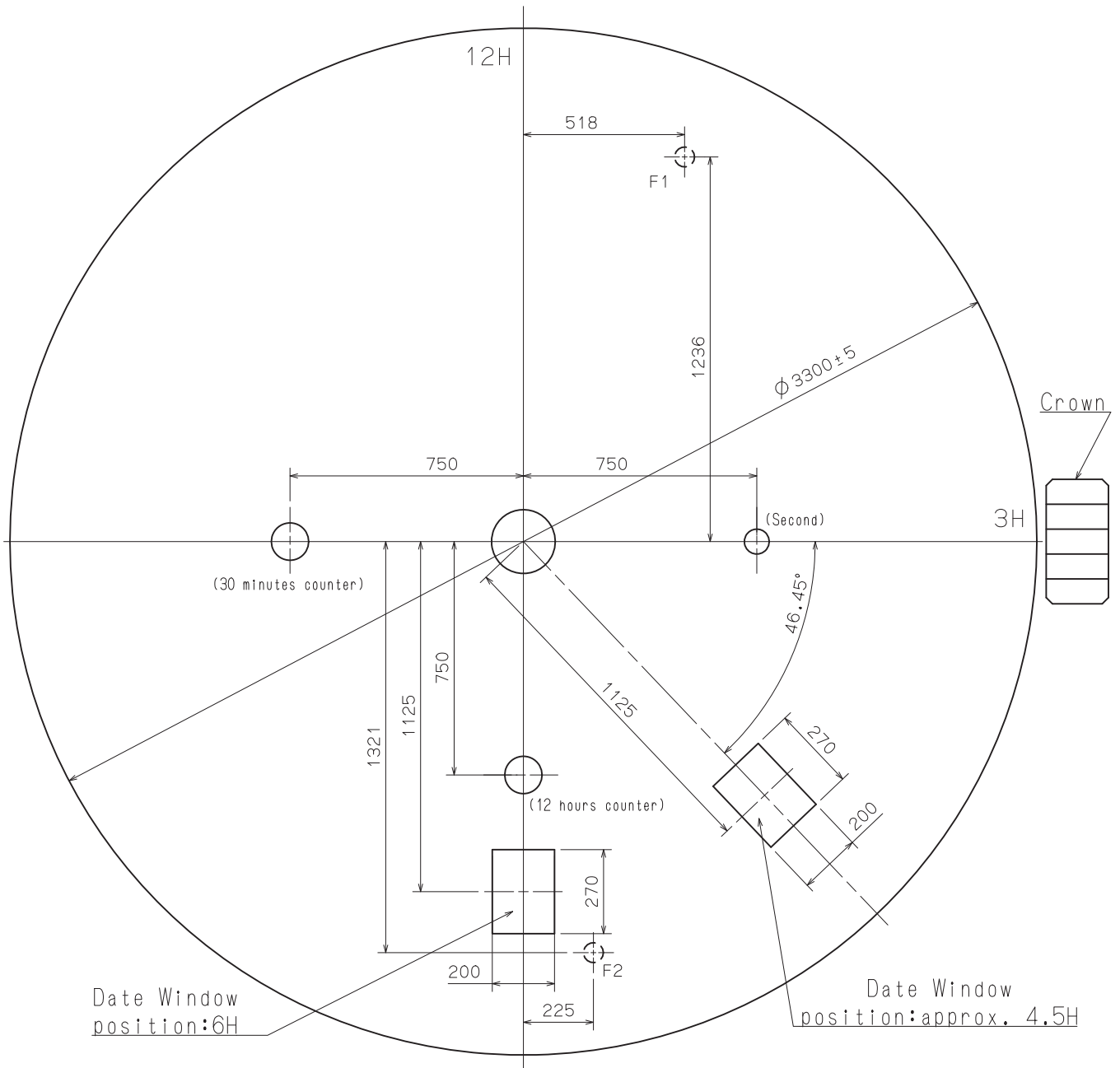

Casing Ring

NE88A

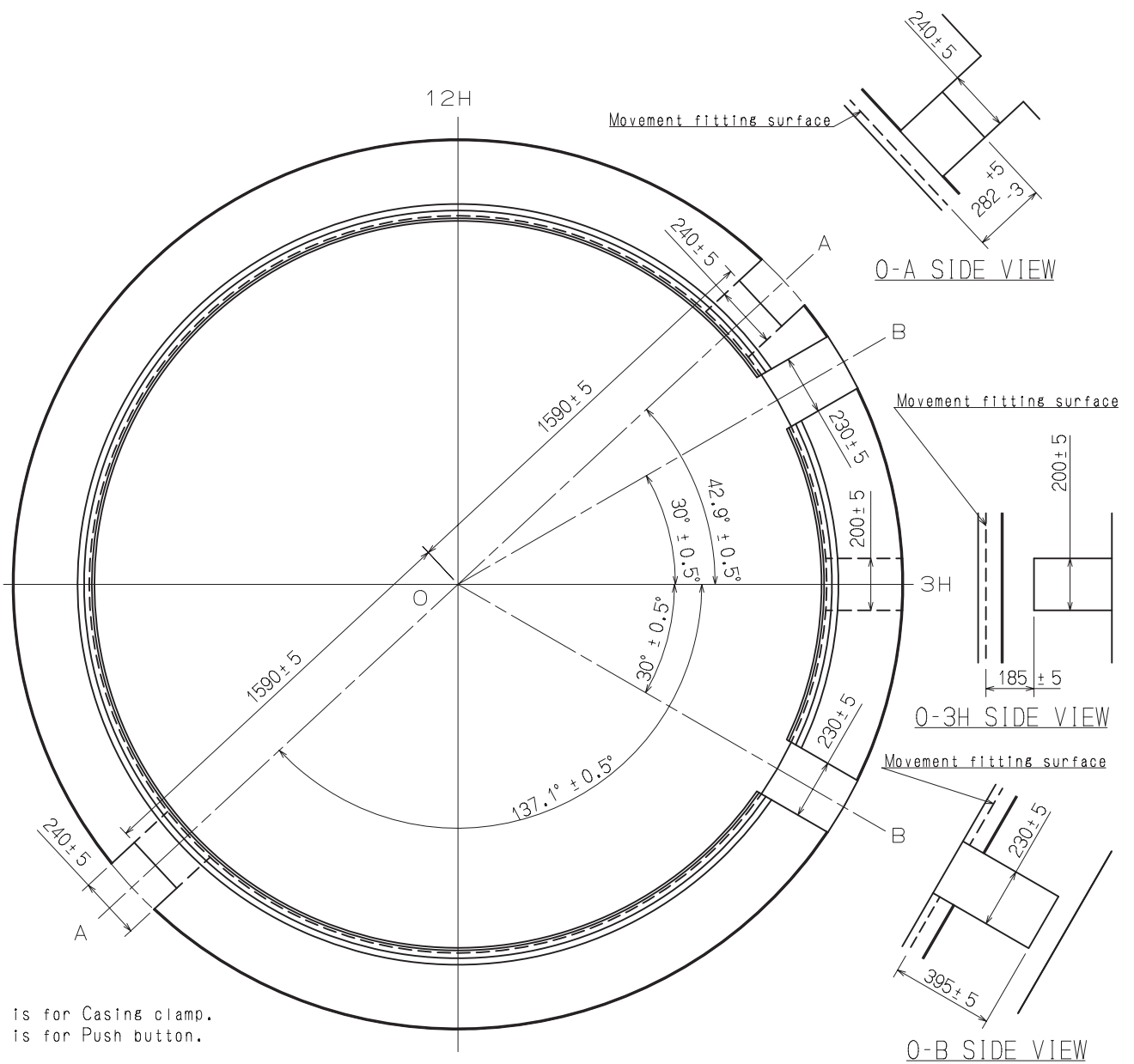

A is for Casing clamp.
B is for Push button.

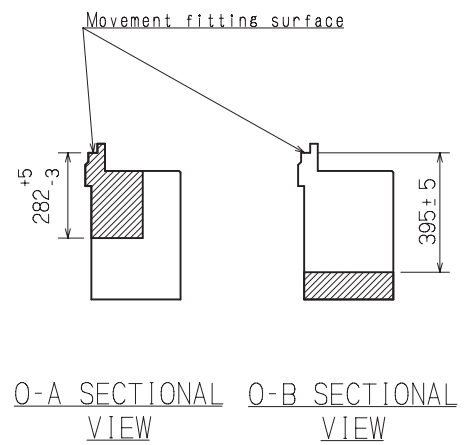
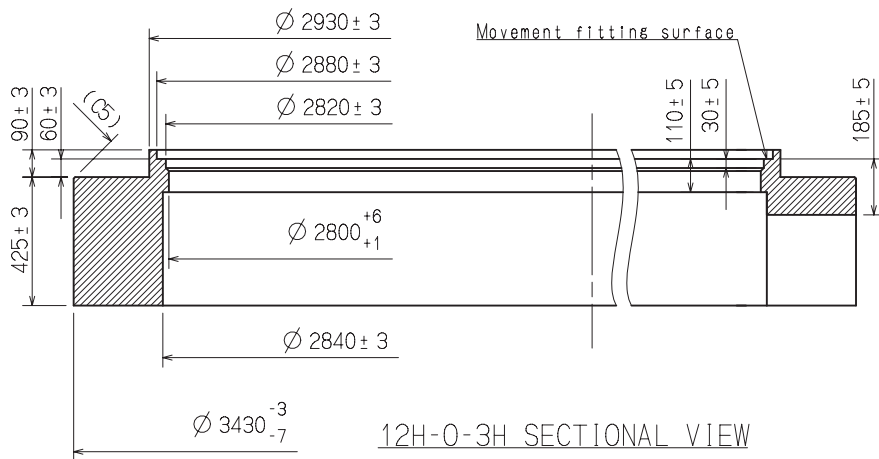

MATERIAL: SUS304

Unit : 1=1/100mm

Version : 1

Casing Clamp

NE88A

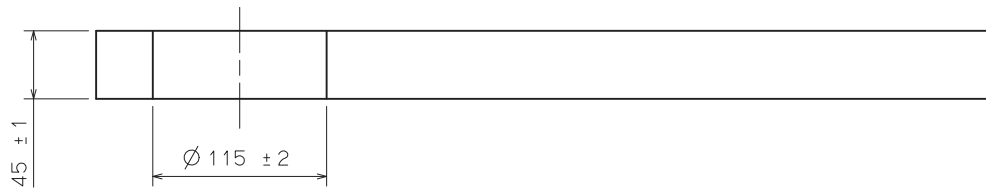
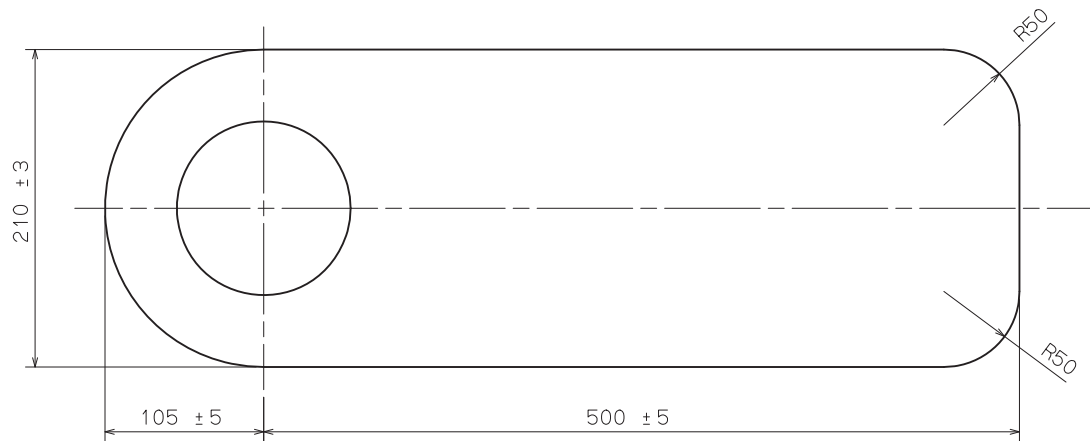

MATERIAL : SUS631-CSP3/4H
HARDNESS : Hv500±30

Unit : 1=1/100mm

Version : 1

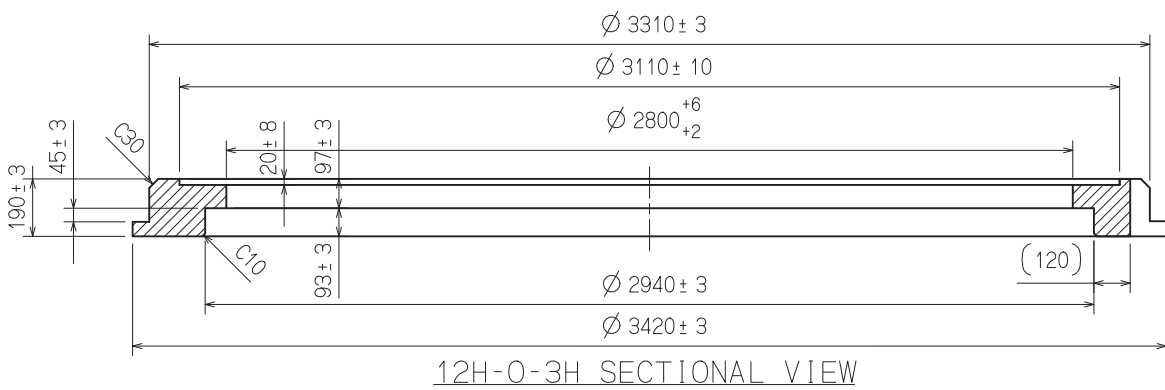
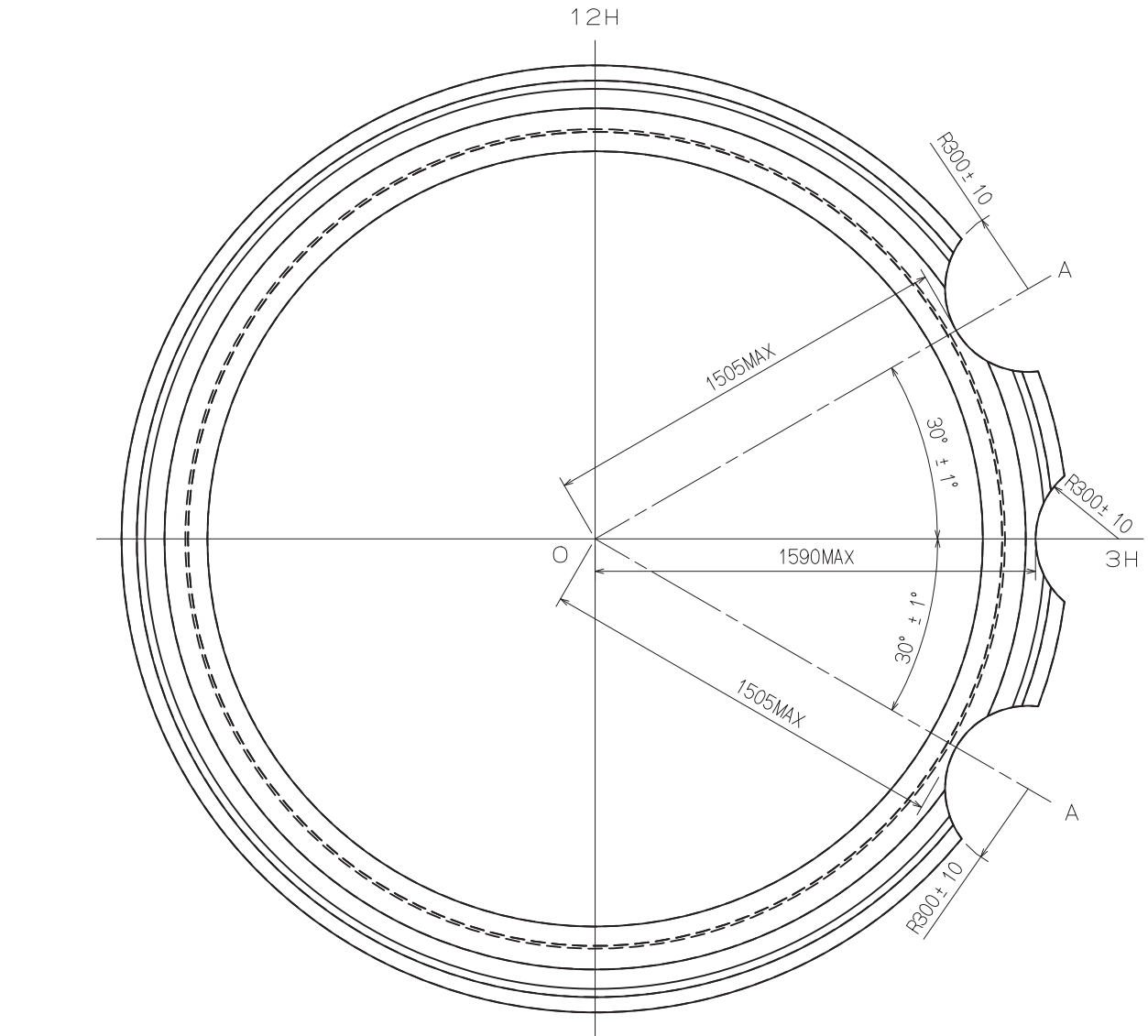

MATERIAL : SUS304

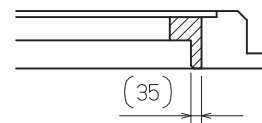

O-A SECTIONAL VIEW

Unit : 1=1/100mm

Version : 1

Assembly Plan

NE88A

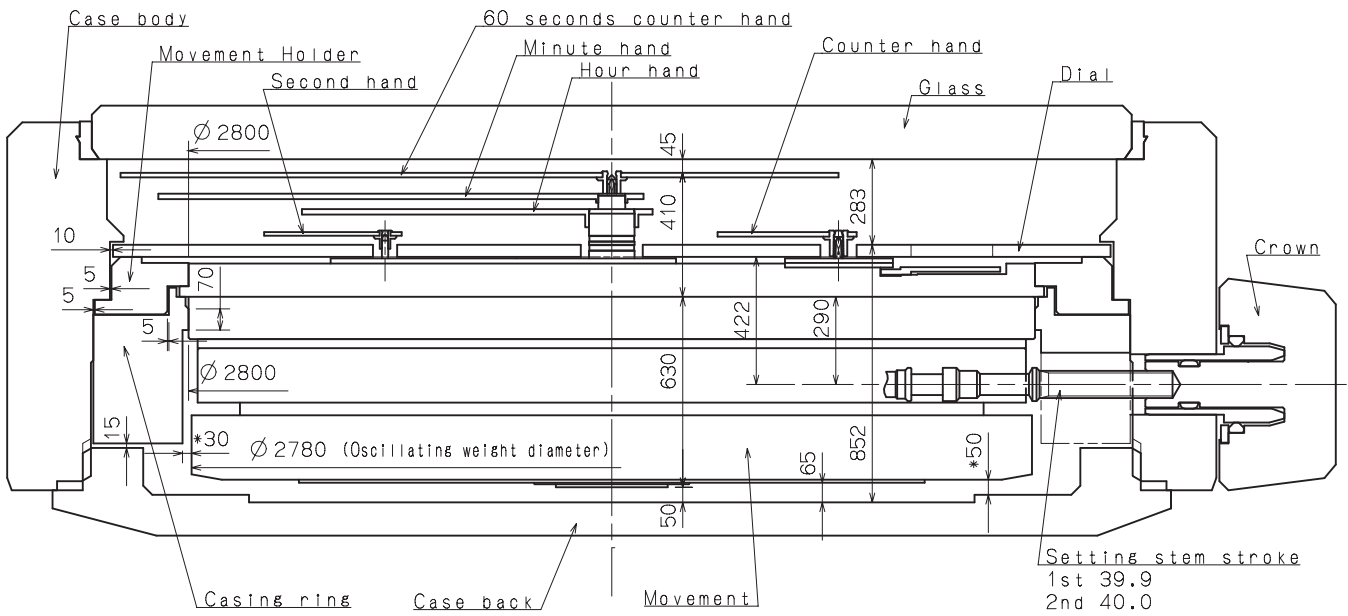

(Note for clearance *30 and *50)
It is STRONGLY RECOMMENDED that these clearance should be applied without modification.

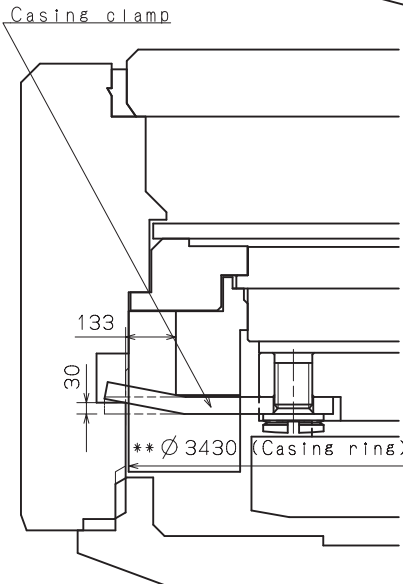
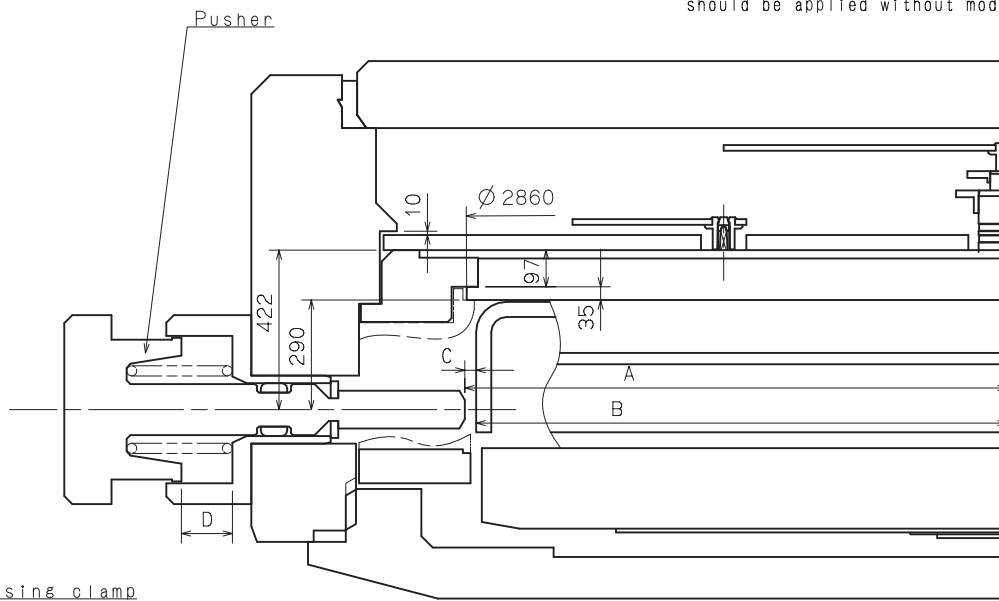

Movement Center

A: Movement Center ~ Pusher tip	1435
B: Movement Center ~ Operating levers	1405
C: Clearance (A-B)	30 (15MIN)
D: Stroke of Pusher (C+105)	135

(Note for maximum diameter of casing ring **)
To ensure the best condition of casing clamp, it is encouraged that the diameter of casing ring does not exceed the indicated dimension.

Unit : 1=1/100mm

Version : 1

SECOND COUNTER

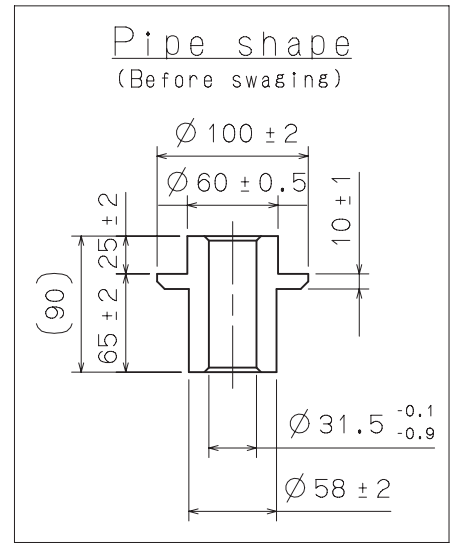
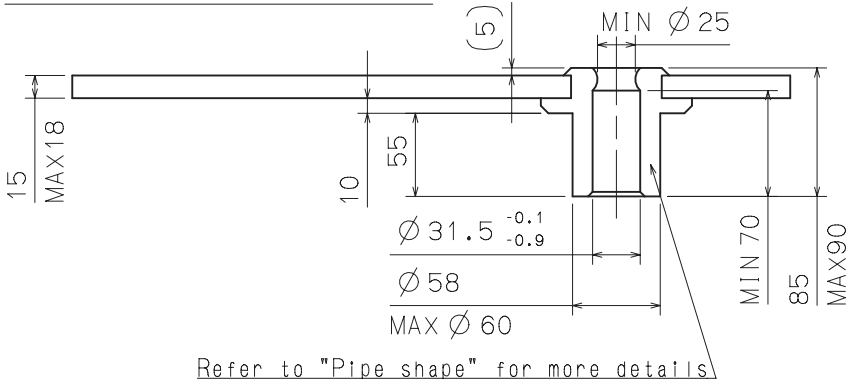

Recommended shape

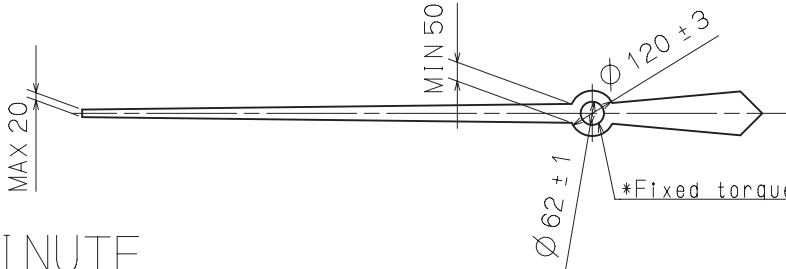

MINUTE

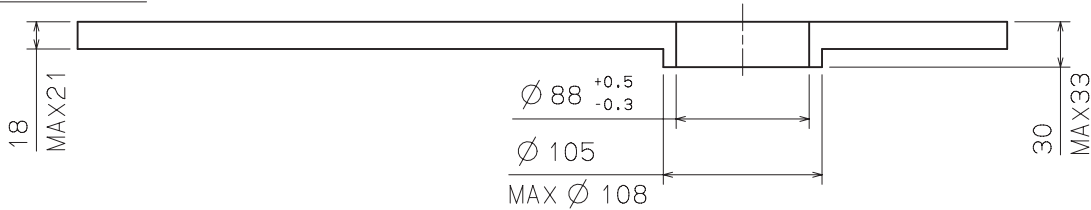

hour

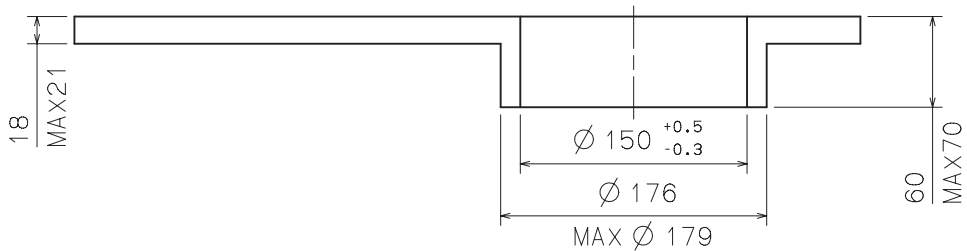

COUNTER

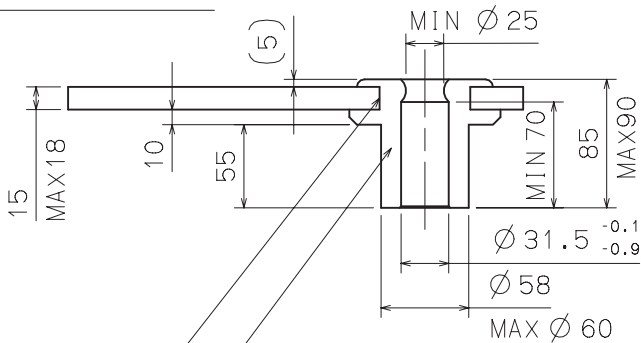

SECOND

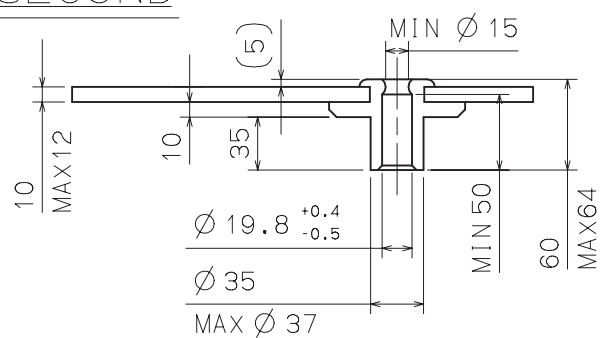

*Fixed torque of Blade and Pipe: 6N·mm(60g·cm)MIN