

RONDA normtech 700 & 6000

Lange Batterielaufzeit und spezielle Funktionen

Caliber 762 – 6³/₄ x 8'''

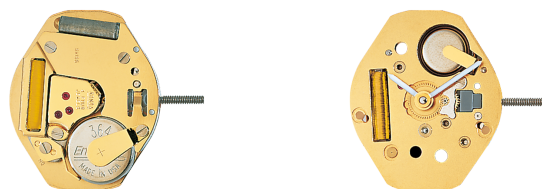

Product Specifications

Analog quartz movement

Line	normtech
Caliber	762
Size	6 ³ / ₄ x 8'''
Version	Swiss Made
	4 Jewels / gold plated
Standard battery life	10 Years
Hand fitting height	1

Features

- Very long battery life
- Repairable metal watch movement
- Power saving mechanism with pulled out stem: Reduction of consumption approximately 70%
- Many high hand heights available

Functions

– 2 hands

Technical Specifications

Diameter Total	15.30 mm
Case fitting	15.30 mm
Movement height	2.50 mm
Height over standard battery	2.65 mm
Movement rest	0.40 mm
Height over stem	1.00 mm
Length of stem travel	0.40 mm
Stem thread	0.90 mm
Standard battery	364
Standard battery life	10 Years
Battery voltage	1.5 V
Current consumption – typical	0.23 µA
Current consumption – maximum	0.3 µA
Useful torque minute – typical	30 µNm
Operating temperature	0 - 50 °C
Instantaneous rate	-10/ +20 sec/month
Resistance to magnetic fields	18.8 Oe
Resistance against shock	NIHS 91-10



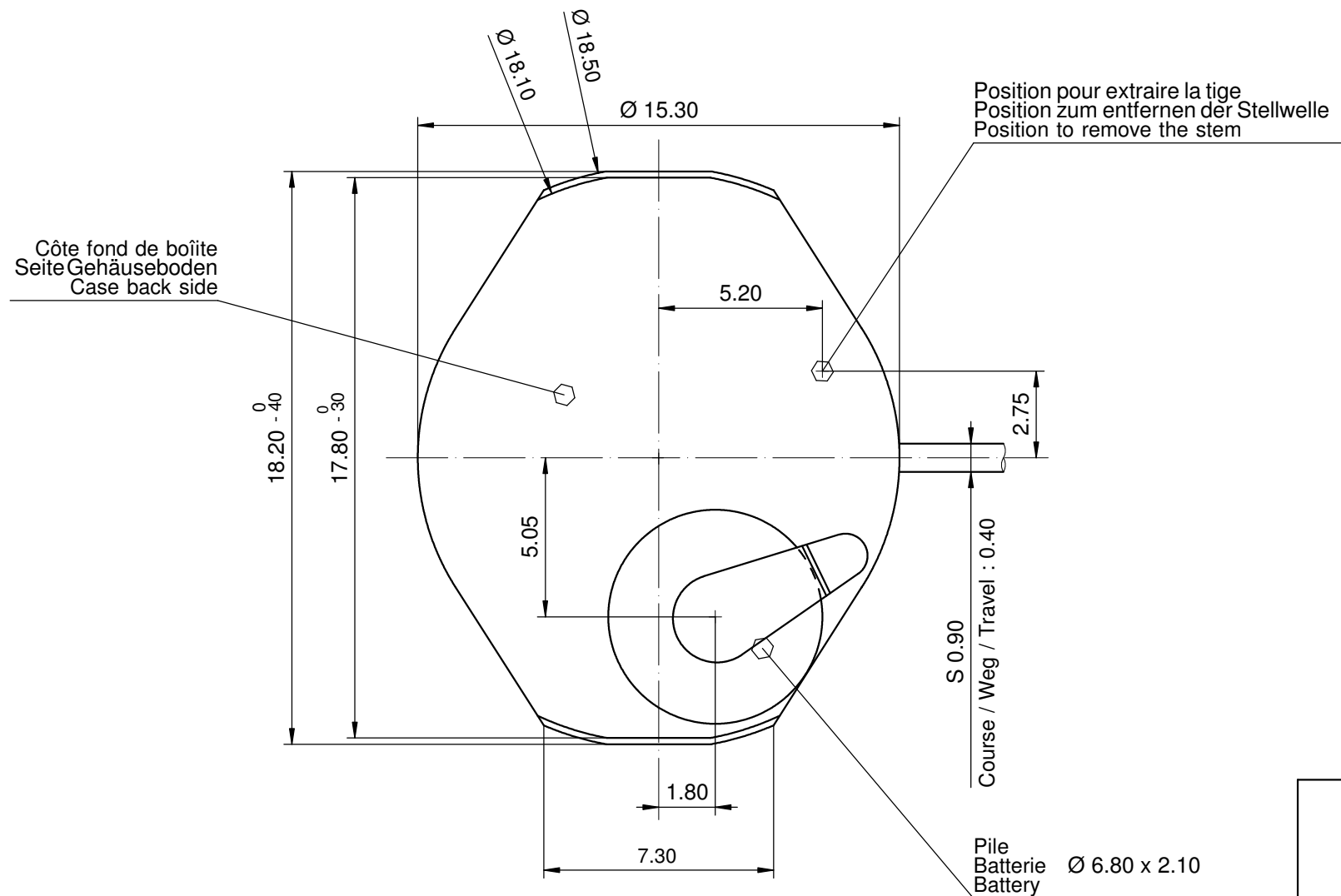
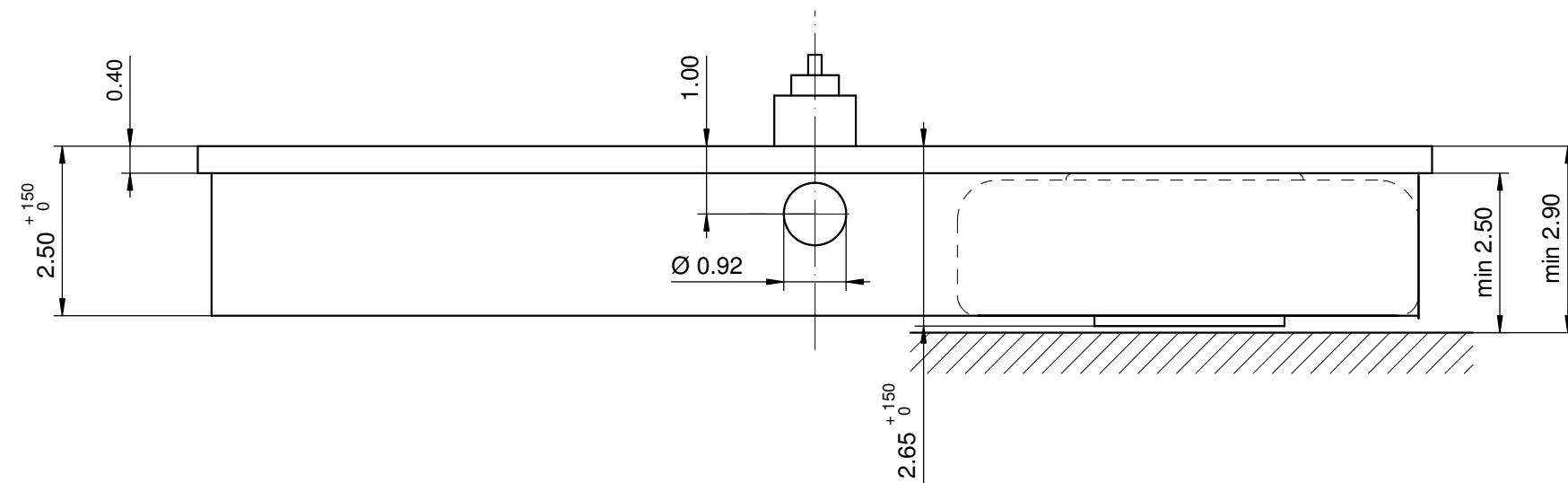

Sécurité entre aiguille seconde et verre : min 0.30 mm
 Sicherheit zwischen Sekundenzeiger und Glas : min 0.30 mm
 Security between second hand and glass : min 0.30 mm

Le cadran doit être maintenu en hauteur par la boîte.
 Das Zifferblatt muss in der Höhe vom Gehäuse festgehalten werden.
 The dial must be held in the height by the case.

Cage Uhrwerkgestell 6 ³ / ₄ x 8''' Frame	Issued	01 Jul 1986	nt
	Modified	09 Apr 2013 ÅA 13338	mc
	Released	YES	
	Tolerance	+/- 20 µm	
	Scale	10 : 1 (5 : 1) (A3H)	
RONDA	762, 762E, 763, 763E, 763R		Sous réserve de modifications Änderungsvorbehalten Modifications reserved
	No.	5000.239	14

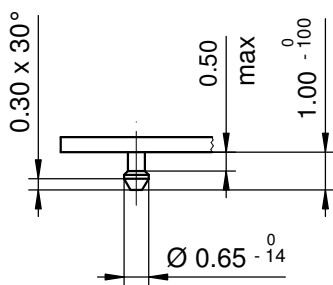
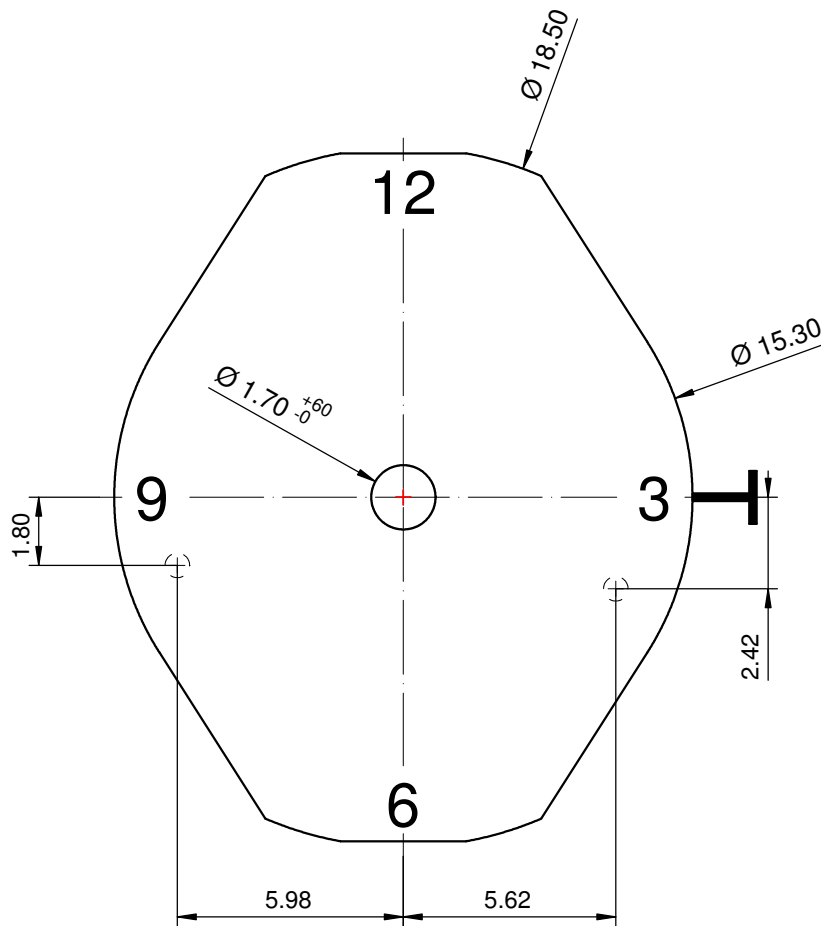

Epaisseur du cadran selon hauteur de l'aiguillage
 Zifferblattdicke gemäss Zeigerwerkhöhen
 Dial thickness according to hand fitting heights

Tige
Stellw.
Stem
3H

Cadran
Zifferblatt 6³/₄ x 8'''
Dial

Issued	12 Dez 2006	cw
Modified	09 Apr 2013 ÄA 13338	mc
Released	YES	
Tolerance	+/- 20 µm	
Scale	5 : 1 (A4V)	

RONDA

762, 762E, 763, 763E

Sous réserve de modifications
 Aenderungenvorbehalten
 Modifications reserved

No.	5010.381	06
-----	----------	----

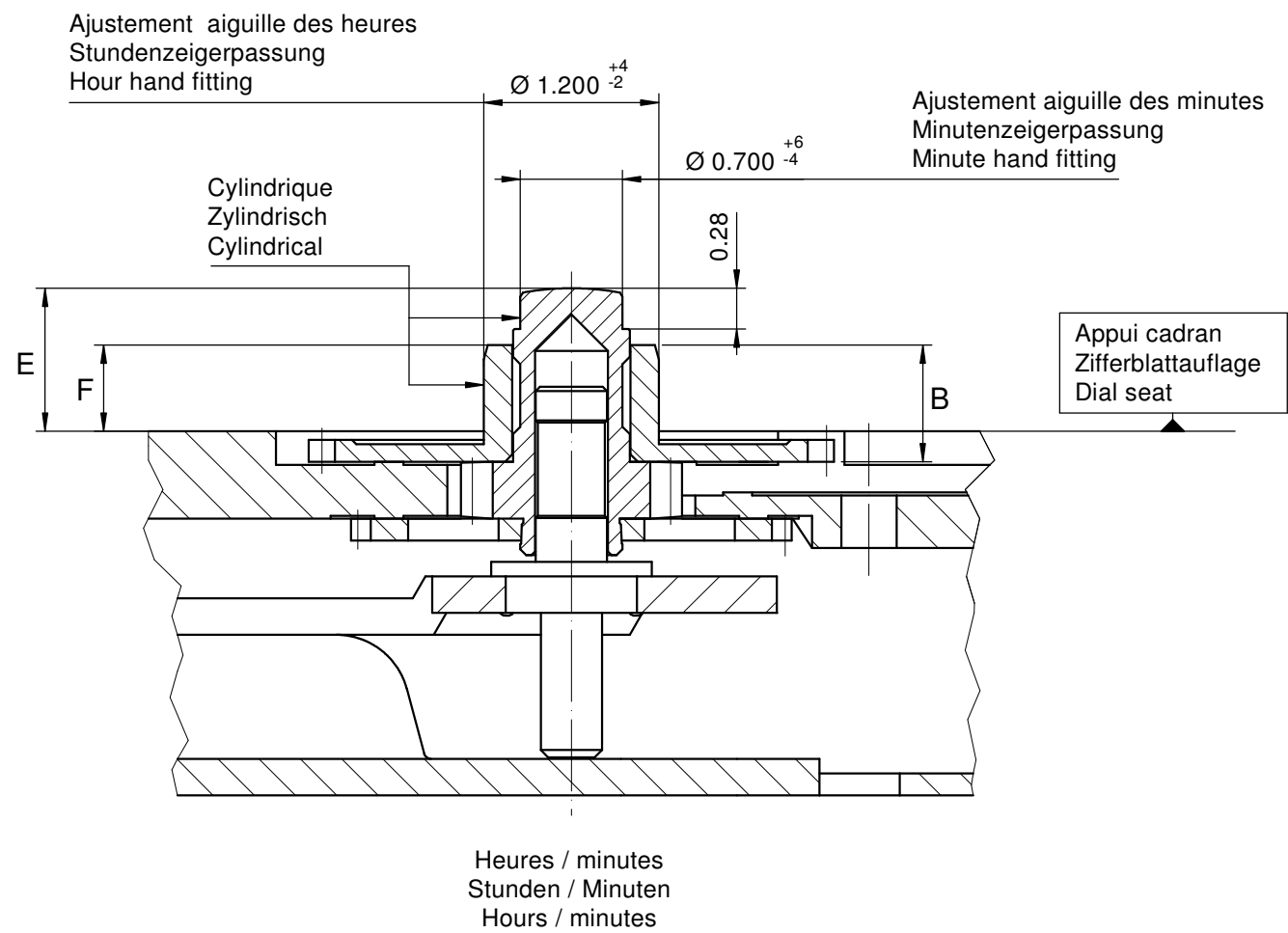

Aiguillage no Zeigerwerkhöhe Nr. Hand fitting height No	Dépassement Höhe über Zifferblattaufgabe Height over dial seat			Longueur Länge Length		Epaisseur max. (peinture comprise) Max. Dicke (inkl. Farbe) Max. thickness (paint included)		
	Chaussée Minutenrohr Cannon-pinion	Roue des heures Stundenrad Hour wheel		Roue des heures Stundenrad Hour wheel		Cadran Zifferblatt Dial		Aiguilles Zeiger Hands
						Sous l'aiguille des minutes Unter Minutenzeiger Under minute hand	Sous l'aiguille des heures Unter Stundenzeiger Under hour hand	
E	F		B					
0	0.95	0.60		0.80		0.50	0.30	0.15
1	1.10	0.75		0.95		0.65	0.40	0.15
2	1.30	0.95		1.15		0.85	0.60	0.15
3	1.80	1.35		1.57		1.35	1.00	0.15
4	2.70	2.35		2.55		2.25	2.00	0.15
5	3.30	2.95		3.15		2.85	2.60	0.15

	Aig. des minutes Minutenzeiger Minute hand	Aig. des heures Stundenzeiger Hour hand	Lors de la pose d'aiguilles, le mouvement doit être soutenu. Beim Zeigersetzen muss das Werk abgestützt werden. The movement needs to be supported for hand setting.
mg max.	30	30	Masse / Masse / Weight *
µNm max.	0.14	0.14	Balourd / Unwucht / Unbalance *
gmm ² max.	-	-	Inertie / Massenträgheit / Inertia *
N max.	40	40	Force de chassage / Aufpresskraft / Force

Aiguillages Zeigerwerkhöhen 5½", 6¾ x 8" Hand fitting heights		Issued	18 Feb 2001	mk
		Modified	06 Jan 2016 ÄA 13573	dh
		Released	Yes	
		Tolerance	µm	
		Scale	20 : 1 (A3H)	
RONDA	751, 756, 762, 762E	Sous réserve de modifications Änderungen vorbehalten Modifications reserved		
		No.	3316.002	20

* En cas de données différentes, veuillez contacter le service après-vente

* Bei abweichenden Werten, bitte technischen Kundendienst anfragen

* In case of different values, please contact the customer service

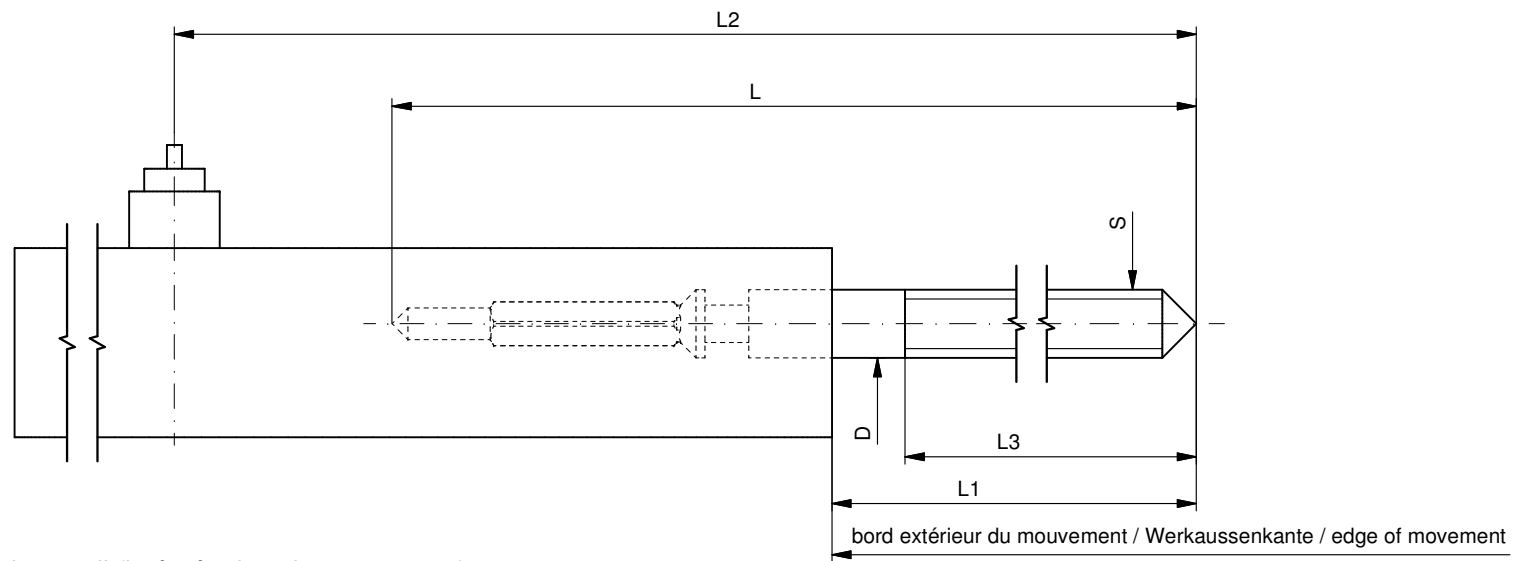

Tige de travail (intégrée dans le mouvement)
 Arbeitstellwelle (im Werk eingebaut)
 Working stem (implemented in the movement)

No. d'article Artikelnummer Part number	L	L1	L2	L3	S	D
3000.132.CO	17.00	11.57	19.22	12.70	0.90	0.90

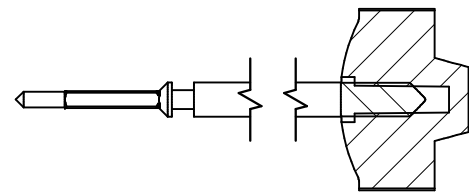

Couleur de la couronne Kronenfarbe Crown color	bleu clair hellblau pale blue
Code	FR 9194

Tige (normale) / Stellwelle (normal) / Stem (normal)

No. d'article Artikelnummer Part number	L	L1	L2	L3	S	D
3000.132	17.00	11.57	19.22	12.70	0.90	0.90
3000.156	25.00	19.57	27.22	14.80	0.90	0.90
3000.139	32.00	26.57	34.22	18.80	0.90	0.90
3000.173	17.00	11.57	19.22	12.60	0.70	0.90

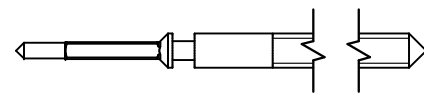

Tige (à arracher)
 Stellwelle (Ausreissversion)
 Stem (extractable version)

No. d'article Artikelnummer Part number	L	L1	L2	L3	S	D
3000.143	17.00	11.57	19.22	12.70	0.90	0.90

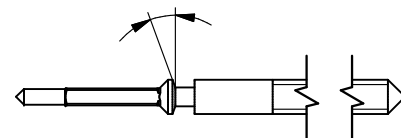

Rallonge de tige / Stellwelle Verlängerung / Stem extension

No. d'article Artikelnummer Part number	L4	L5 (min)	L6	S1	S2	D1
3000.040	12.00	1.90	2.60	0.90	0.90	1.35
3000.046	12.00	1.90	2.60	0.70	0.70	1.00

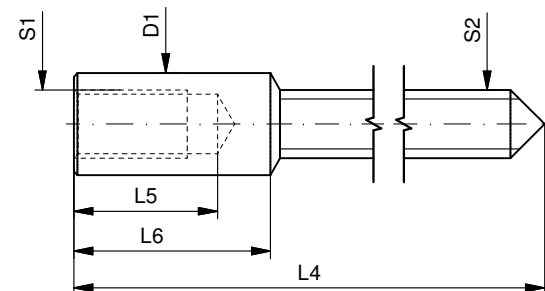

Couronne normale
 Normale Krone
 Normal crown

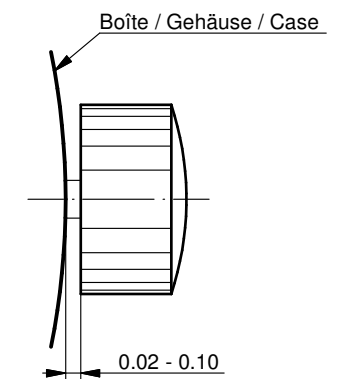

Couronne vissée
 Geschraubte Krone
 Screwed crown

Force ⇐ min. Kraft ⇐ min. Force ⇐ min.	10 N
Force ⇐ max. Kraft ⇐ max. Force ⇐ max.	15 N

Tige (dimensions / forces)
 Stellwelle (Dimensionen / Kräfte)
 Stem (dimensions / forces)

RONDA 762, 762E, 763, 763E

Issued	31 Aug 2012	ds5222
Modified	17 Mär 2017 ÄA 34582	mg5224
Released	YES	
Tolerance	---	
Scale	10:1 (A3)	

Sous réserve de modifications
 Änderungen vorbehalten
 Modifications reserved

No.	5030.013	03
-----	----------	----

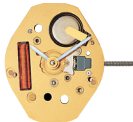

6 ³/₄ x 8'''



762/762H



763

Funktionen

Fonctions

Functions

Kaliber Calibre Caliber	Stellwellenpos. Pos. de tige Stem position	Funktionen Fonctions Functions
762 / 762H	1	Normale Position / Position normale / Running position
	2	Zeiger stellen / Mise à l'heure / Hand setting
763	1	Normale Position / Position normale / Running position
	2	Zeiger stellen, Sekunden-Stopp mit Unterbruch der Motorimpulse Mise à l'heure, stop-seconde avec interruption des impulsions moteur Hand setting, stop-second with interruption of motor pulses

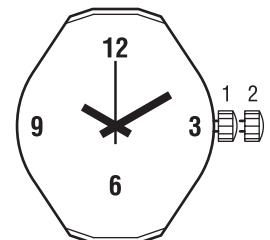

Batterie

Pile

Battery

Kaliber Calibre Caliber	Batterie Pile Battery	Spannung Voltage Tension	Artikelnummer RONDA Numero d'article RONDA Part number RONDA
762/762H/763	364/SR621SW	1.55 V	3600.013.HGF

6 3/4 x 8''' 762, 762H, 763

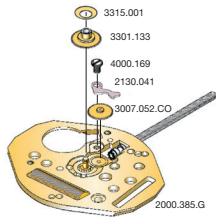
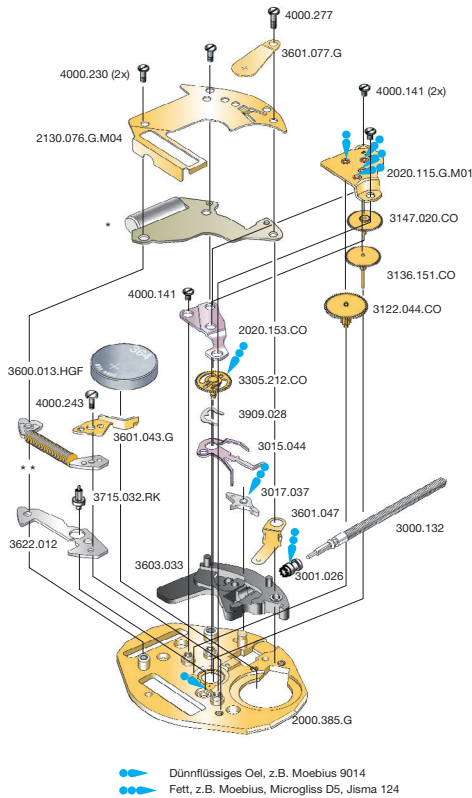

	762 SWISS MADE	762 SWISS PARTS	763 SWISS MADE	763 SWISS PARTS
* Modul (neu) Module (nouvelle) Module (new)	3612.159 grün vert green		3612.160 blau bleu blue	3612.151 weiss blanc white
** Spule (neu) Bobine (nouvelle) Coil (new)	3621.061.RK gelb jaune yellow			

	762 SWISS MADE	762 SWISS PARTS	763 SWISS MADE	763 SWISS PARTS
* Modul (alt) Module (vielle) Module (old)	3612.096 rot rouge red		3612.112 gelb jaune yellow	3612.076
** Spule (alt) Bobine (vielle) Coil (old)	3621.014.RK rot rouge red			

Abweichungen / Divergences / Deviations

Cal. 763			
Werkseite / Côté mouvement / Movement side			
Plan No.	Bestandteile	Fournitures	Spare Parts
2000.385.G	Werkplatte	Platine	Main plate
2020.115.G.M01	Räderwerkbrücke	Pont rouge	Train w. bridge
2020.153.CO	Zentrumbrücke	Pont centre	Centre bridge
2130.076.G.M04	Modul-Abdeckpl.	Couvre module	Module cover pl.
3000.132	Stellwelle	Tige	Stem
3001.026	Kupplungstrieb	Pignon coulant	Sliding pinion
3015.044	Kuppl.-triebhebel	Bascule	Yoke
3017.037	Winkelhebel	Tirette	Setting lever
3122.044.CO	Kleinbodenrad	Roue moyenne	Third wheel
3136.151.CO	Sekundenrad	Roue secondes	Second-wheel
3147.020.CO	Zwischenrad	Roue interméd.	Intermed. wheel
3305.212.CO	Minutenrohr	Chaussée	Cannon pinion
3600.013.HGF	Batterie	Pile	Battery
3601.043.G	Batteriehalter	Bride pile	Battery clamp
3601.047	Batt.-Kontakt	Bride contact	Battery contact
3601.077.G	Batteriehalter	Bride pile	Battery clamp
3603.033	Kunststoffzw.teil	Potence plastique	Setting m. cover
*	Modul	Module	Module
**	Spule	Bobine	Coil
3622.012	Stator	Stator	Stator
3715.032.RK	Rotor	Rotor	Rotor
3909.028	K.-triebhebel	Clavette bascule	Pillar spring clip
4000.141	Schraube	Vis	Screw
4000.230	Schraube	Vis	Screw
4000.243	Schraube	Vis	Screw
4000.277	Schraube	Vis	Screw

Cal. 762			
Werkseite / Côté mouvement / Movement side			
Plan No.	Bestandteile	Fournitures	Spare Parts
2020.104.CO	Zentrumbrücke	Pont centre	Centre bridge
2020.116.G.M01	Räderwerkbrücke	Pont rouge	Train w. bridge
2130.076.G.M01	Modul-Abdeckpl.	Couvre module	Module cover pl.
3122.045.CO	Kleinbodenrad	Roue moyenne	Third wheel
3305.174.CO	Minutenrohr	Chaussée	Cannon pinion
*	Modul	Module	Module
3622.018	Stator	Stator	Stator
3715.100.RK	Rotor	Rotor	Rotor

Cal. 762H			
Werkseite / Côté mouvement / Movement side			
Plan No.	Bestandteile	Fournitures	Spare Parts
3305.198.CO	Minutenrohr	Chaussée	Cannon pinion

Cal. 762, 763			
Zifferblattseite / Côté cadran / Dial side			
Plan No.	Bestandteile	Fournitures	Spare Parts
2130.041	Zeigerwerkplatte	Plaque maintien	Maintaining plate
3007.052.CO	Wechselrad	Minuterie	Minute wheel
3301.133	Stundenrad	Canon	Hour wheel
3315.001	Spreizfeder 2 1/2	Clinquant 2 1/2	Washer 2 1/2
4000.169	Schraube	Vis	Screw

Cal. 762H			
Zifferblattseite / Côté cadran / Dial side			
Plan No.	Bestandteile	Fournitures	Spare Parts
3301.176	Stundenrad	Canon	Hour wheel

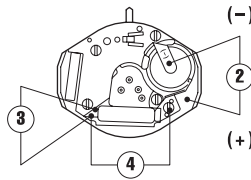
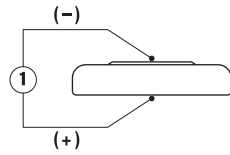

Kaliber Calibre Caliber	Pos. Pos. Pos.	Einheit Unité Unit	Messwerte Valeurs mesurées Measured values	Kontrolle Contrôle Check	Bemerkungen Remarques Remarks
762/763 762H	1	V	1,55	Batterie-Spannung Tension de la pile Battery voltage	Batterie herausnehmen und messen Enlever et mesurer la pile Remove battery for measuring
762, 762H Puls/10 sec., impulsion/10s., pulse/10 sec.		µA	0,20–0,50 ~ 1,3–2,2	Stromaufnahme Consommation de courant Current consumption	Ohne Batterie, mit externer Speisung Sans pile, avec alimentation externe Without battery, with external power supply
763		µA	0,70–1,10		
762/763 762H	2	V	≤ 1,30	Funktionskontrolle bei Minimalspannung Contrôle de fonctionnement à tension min. Check with lowest possible voltage	Ohne Batterie, mit externer Speisung Sans pile, avec alimentation externe Without battery, with external power supply
762/763 762H	3	KΩ	1,40–1,60 (2,60–2,90*)	Spulenwiderstand Résistance de la bobine Resistance of the coil	Ohne Batterie Sans pile Without battery
762/763 762H	4	KΩ	∞	Spulenisolation Isolation de la bobine Coil insulation	Ohne Batterie Sans pile Without battery
762/763 762H		Sek./Monat sec./mois sec./month	- 10/+ 20	Induktivsonde 60 Sek. Senseur inductif 60 sec. Inductive sensor 60 sec.	Mit Batterie Avec pile With battery

Werte (*) gelten für rote Spule (s. Seite 2)

Valeurs (*) sont valid pour bobine rouge (v. page 2)

Values (*) are valid for red coil (see pages 2)

Einschalen / Werkzeuge

Nr. H 76x.1A



Emboîtage / outils

Nr. H 76x.1T



H 76x.1A	SWISS MADE & SWISS PARTS
Schraube Vis Screw	

Zeigersetzen

Maximale Aufpresskraft:

- Stunden und Minutenzeiger: max. 40N
- Sekundenzeiger: max. 30N

Beim Zeigersetzen muss das Werk abgestützt werden.

Poser les aiguilles

Force de chassage maximale:

- Aiguilles des heure et des minutes: max. 40N
- Aiguille des secondes: max. 30N

Lors de la pose d'aiguilles, le mouvement doit être soutenu.

Hand setting

Maximal force:

- Hour and minute hands: max. 40N
- Second hand: max. 30N

The movement needs to be supported for hand setting.

Casing / tools

Stellwelle entfernen

Beim Entfernen der Stellwelle muss sich die Stellwelle in Position 1 (gedrückt) befinden, bevor auf den Winkelhebel gedrückt wird.

Enlever la tige

En enlevant la tige, la tige doit se trouver en position 1 (poussée), avant de pousser sur la tirette.

Stem removal

For removal of the stem, the stem must be pushed into position 1 (pressed in) prior to apply pressure to the setting lever.